

Coastal Ecology Series No. 4

**Dunes, Groundwater,
Mangroves and
Birdlife in Coastal
Kenya**

Jan Hoorweg

Editor

Malindi

Mombasa

Moi University, Eldoret
School of Environmental Studies

Shimoni

**DUNES, GROUNDWATER, MANGROVES AND BIRDLIFE
IN COASTAL KENYA**

Coastal Ecology Series

1. Environmental Management, Research and Training in Coast Province, Kenya
2. MUSES Coast Environment Research Priorities
3. CERS Annual Report 1996 & Development Plan
4. Dunes, Groundwater, Mangroves and Birdlife in Coastal Kenya

Coastal Ecology Series No. 4

**DUNES, GROUNDWATER, MANGROVES AND BIRDLIFE
IN COASTAL KENYA**

JAN HOORWEG

Editor

School of Environmental Studies

1998

© Moi University, Eldoret, 1998

Published in Kenya by Acts Press
African Centre for Technology Studies
P.O.Box 45917, Nairobi
Tel.: (254-2) 565173, 569986; Fax: 573002

Printed by English Press Ltd.
P.O. Box 30127, Nairobi

Cataloguing in Publication Data

Dunes, groundwater, mangroves and birdlife in coastal Kenya/
Jan Hoorweg.— Nairobi, Kenya: Acts Press, 1998

(Coastal Ecology Series No. 4)

Cover Design: Andrew Akhonya

ISBN 9966-41-101-1

Contents

List of Tables	vi
List of Figures	vii
1. Introduction. <i>J. Hoorweg</i>	1
2. Geology, geomorphology, oceanography and meteorology of Malindi Bay. <i>J. Abuodha</i>	17
3. Composition, structure and distribution of coastal dune vegetation between Malindi and Mamburi. <i>W.M. Musila</i>	41
4. Environmental effects of coastal sedimentation: A case study of Shirazi-Funzi Lagoon. <i>T.M. Munyao</i>	59
5. Groundwater resources and sea water intrusion in Kwale District. <i>S.O. Anyanango, M.P. Tole & E.K. Ucakuwun</i>	73
6. The impact of geology and pit latrines on ground water quality in Kwale District. <i>J.M. Mzuga, M.P. Tole & E.K. Ucakuwun</i>	85
7. Mangrove conservation and management: A structural regime for the Kenyan coastline. <i>E.M. Ouko & S. Manobar</i>	97
8. Mangrove forests along the tidal flats and lagoons of Ngomeni, Ungwana Bay. <i>F.K. Kamau</i>	111
9. East Coast Akalat: Habitat selection and distribution in Arabuko-Sokoke forest. <i>P.M. Matiku, L. Bennun & J.F.E. Odanga</i>	135
Authors	153

List of Tables

2.1	Chronology of the Pleistocene and Holocene events in the southern coast of Kenya based on earlier studies	28
2.2	Correlation of the coastal terraces in southern Kenya according to earlier studies	30
3.1	Species richness and different growth forms by geomorphological units	46
3.2	Range of chemical measures of the dune soils in different geomorphological units	52
4.1	Stratigraphy of the Mombasa basin	60
4.2	Table of possible effective flooding in Shirazi-Funzi area in the event of sea level rise	64
4.3	Results of salinity and POC analysis for samples from Kiwambale sampling station, Mamuja channel	65
4.4	General properties of sediments of Uvinje channel of Shirazi-Funzi lagoon	67
4.5	Exploitation of mangrove and fish resources in the Shirazi-Funzi lagoon	68
4.6	Correlation matrix for socio-economic activities in the Shirazi-Funzi lagoon	69
5.1	Classification of water on the basis of TDS by catchment area	78
5.2	Physico-chemical parameters by catchment area	79
5.3	Results of selected parameteres for boreholes measured in 1987 and 1993	80
5.4	Distribution of SAR values by catchment area	80
6.1	Number of boreholes, wells and springs sampled by region	88
6.2	Average seasonal comparison of physico-chemical parameters	88
6.3	Specific conductivity and TDS	90
6.4	Total coliform distribution for boreholes, wells and springs	91
6.5	E. coli contamination by location	91
7.1	Structural attributes of mangrove species at Shimoni swamp	100
7.2	Importance Value Index and Rank of mangrove species at Shimoni area	100
7.3	Structural attributes of mangrove species at Gazi swamp	100
7.4	Importance Value Index and Rank of mangrove species at Gazi swamp	102
7.5	Structural attributes of mangrove species at Mida Creek	102
7.6	Importance Value Index and Rank of mangrove species at Mida Creek	102
7.7	Structural attributes of mangrove species at Ngomeni swamp	104
7.8	Importance Value Index and Rank of mangrove species at Ngomeni swamp	104
8.1	Density by species	118
8.2	Basal area by species	118
8.3	Mean pooled epifauna, and infauna densities, and species diversity representing different biotopes	119
8.4	Mean pooled physical parameters in the different biotopes	120
8.5	Mean pooled concentrations for ammonium-nitrogen, nitrate-nitrogen, phosphate, and sulphates	122
9.1	Akalat population size and density by forest type	138
9.2	T-test between habitat parameters from Cynometra woodland and Mixed forest Akalat present whole plots	138
9.3	Comparison of habitat parameters from 11, 200 X 200 m-plots each from Cynometra woodland and Mixed forest	140

9.4	Comparison of subplots within 200 X 200 m-plots where Akalat did occur and did not occur in Mixed forest and Cynometra woodland	142
9.5	Comparison of habitat parameters in Akalat "hot spots" in Cynometra woodland and Mixed forest	144
9.6	Logistic regression models selecting habitat parameters which best predict the presence of East Coast Akalat in the Cynometra woodland and the Mixed forest Akalat present and absent sites ("hot spots")	144
9.7	Habitat parameters which best predicted the presence of East Coast Akalat with (+) and without (-) habitat as a factor	146
9.8	Normal multiple regression models selecting habitat parameters which best explain the variation of East Coast Akalat's densities in the Cynometra woodland and the Mixed forest	146

List of Figures

1.1	Map of Southern Kenya Coast with study locations	12
2.1	Wind rose for Kenya coast based on observations by RV Ujuzi in 1980	20
2.2	Currents off the Kenya coast based on observations by RV Ujuzi in 1980	20
2.3	Wave characteristics and current movement off the Malindi coast, 1949-89	20
2.4	Geological map of the coastal zone in the Malindi area	26
2.5	Geomorphological map showing terraces of the coastal zone between Kilifi and Gongoni	34
3.1	Location of the sand dunes near the mouth of the Sabaki River	44
3.2	Location of sample transects near Sabaki River	44
3.3	Geomorphological units of the sand dunes near Sabaki River	44
4.1	24hr variation in tidal level, POC, and salinity of surface water at Kiwambale in Mamuja channel	66
4.2	Variation of mean grain size, sorting, skewness and kurtosis of sediments along Mamuja channel	66
4.3	Exponential dissipation of energy by waves entering Uvinje and Mamuja channels	66
5.1	Concentration of chloride in boreholes in Diani-Tiwi area	74
5.2	Concentration of chloride in boreholes in Msambweni area	76
5.3	Tidal variations as compared to the well water rest levels	82
6.1	The direction of water flow with sampling stations	86
6.2	Total coliforms in boreholes in sandstone area as a function of distance from the nearest pit latrine	92
6.3	Total coliforms in boreholes in limestone area as a function of distance from the nearest pit latrine	92
8.1	Mangrove distribution along the Kenya coastline	112
8.2	Location of study area and the sampling sites	112
8.3	Variations of macro-invertebrate species diversity with respect to four physical parameters	124
9.1	Arabuko Sokoke Forest: Vegetation types, plot distribution and Akalat survey routes	136
9.2	Distribution of the East Coast Akalat in Arabuko-Sokoke Forest	136

1

INTRODUCTION

J. HOORWEG

The East African Coast stretches from the Horn of Africa in Somalia to halfway down Mozambique; extending north and south of the equator it covers an approximate distance of 3000km. The continental shelf is fairly narrow with gentle slopes and variations in sea water level have profoundly influenced the coastline relief. The sea floor is characterised by sandy bottoms and rugged formations of old coral rock; the landside has limestone cliffs and outcroppings with elevations of 30m and more (Frazier, 1993). The ecological variation along the coastline is perhaps less than expected over such a long distance. The semi-desert in Somalia is followed by forests, scrub- and grasslands in Kenya and Tanzania interspersed by the estuaries of the large rivers reaching the Indian Ocean. Most of this coastline is lightly inhabited with less than 10 persons/km² (Stuart & Stuart, 1995). Large parts in Kenya, Tanzania and Mozambique have higher densities and have been populous for centuries.

Coral reefs, wetlands, mangroves, and coastal forests are important ecosystems of the East African Coast that have received different degrees of attention from conservationists and ecologists. Coral reefs are among the most complex marine systems with great biodiversity that are found offshore of all East African countries. Mangrove forests are widespread, except in Somalia, and they provide nurseries for fish and crustaceans and protect the coastline from erosion. Coastal wetlands are meeting grounds of marine and terrestrial species. Important estuaries are those of the Juba, Tana and Rufiji Rivers. The coastal forests, finally, have seasonal rainfall with a prolonged dry season; they contain relatively large numbers of endemic species.

Kenyan Coast

Kenya has had a reputation for natural beauty and its conservation since the last century, particularly in respect to the highland savannah and its large mammals. Many areas are now protected. According to its recent list the Kenya Wildlife Service manages 25 National Parks, 29 National Reserves and three sanctuaries covering more than 40,000km² and it is also responsible for game control elsewhere (KWS, 1996). In addition, there are Forest Reserves and areas that have been designated as National Monuments.¹ To maintain this heritage requires dedication and effort but also financial resources, manpower and expertise. The need for ecological conservation versus population pressure and economic exploitation is a recurrent theme in nature and wildlife management. Recent ideas about community participation are an attempt to combine conservation and exploitation. To guide and assist these efforts has created even greater need for environmental expertise.

Coast Province offers a mix of topographical and agro-ecological zones quite different from those of the highland areas. The coastal plain reaches land inward to the foot plateau which is followed, in turn, by the coastal range rising to 200-300m altitude and, finally, the dry hinterland, the Nyika plateau. Different agro-ecological zones alternate over relatively short distances (Jaetzold & Schmidt, 1983). The coconut-cassava zone is generally close to the coastline, followed by the cashewnut-cassava zone and the livestock-millet zone in the hinterland. The so-called coastal strip, an area extending 15-20km inland, has a distinct social and cultural heritage. Historically it belonged to the Omani Sultanate and has a strong Islamic presence. Today it is still the most populated part of the coast. The important ecosystems, mentioned above, are all found there.

The coastal strip extends over an aerial distance of some 450km but the actual length of

1. Forest Reserves resort under the Department of Forestry; National Monuments under the National Museums of Kenya.

the seafront is around 600km. It consists of coral reefs, bays, estuaries, creeks, rocky cliffs, sandy beaches and dunes. In the far south at the border with Tanzania, there are extensive mangroves and coral reefs with near-shore islands such as Wasini. About 50km north, the first concentration of tourist hotels is found in Diani. Mombasa Island lies in a creek system with natural harbours on both sides. More hotel concentration stretches for about 20 km to the north of Mombasa. Rugged coast and the deep water creeks of Mtwapa and Kilifi follow. The shallow Mida creek is the next landmark. Halfway up the coast, the reef ends in Malindi, the second largest town in the coastal strip. Geologically and ecologically, the region north of Malindi is quite different from that to the south. Along Ungwana Bay, landscape and habitation change significantly. The beaches are long and sandy, open to the sea with rolling breakers; the coastal plain which has been narrow until now, widens and along the Tana River extends much further inland. The coastline consists of dunes and scrub vegetation and is sparsely inhabited, only interrupted by what is known as the Tana River Delta with wetlands and mangroves and the limestone cliffs of Ras Shaka (Frazier, 1993). To the north, the remote Lamu archipelago is little developed and consists of near-shore islands, coral reefs, bays, creeks and large mangrove forests.

The coral reefs of Kenya are mainly of the fringing type; closely following the coastline and often linked to the mainland at low tide. The reefs are interrupted where rivers are discharging into the sea but there is a more or less continuous stretch of 200km between Shimoni and Malindi. Reefs also exist north of the Tana River in the Lamu-Kiunga area. There are few corals between the Sabaki and Tana Rivers as a result of the discharge of freshwater and sediments. The Kenyan reefs provide examples of the abundant productivity of these marine ecosystems with many coral species, and a great variety of fish and other reef animals. Of the four ecosystems mentioned earlier, the coral reefs are probably threatened most because they suffer the combined effects of different factors. They are affected by siltation of the main rivers but are also being attacked by natural enemies, notably sea urchins (McClanahan & Obura, 1996). They are also affected by pollution of unprocessed sewage from beach hotels and urban areas. They suffer the effects of shell and coral collection and intense exploitation by fisheries of different types. Finally, they are inevitably damaged by tourist trips to coral gardens.

Coastal wetlands are associated with rivers and other outlets. They experience a daily cycle of wet/dry conditions in creeks and bays or seasonal flooding in deltas and estuaries and combinations of the two. Wetlands are productive ecosystems particularly where fresh and salt water meet with rich plant and animal communities. They provide breeding and feeding habitats for wildlife, including birds following migration routes from Europe and

Asia. The major wetlands are the swamps of the Tana Delta, roughly 30x20km in size, which experience strong seasonal expansion after the rains in the highlands; the area and its ecosystems have received little study so far. The Tana and Sabaki Rivers are the only rivers that originate in the highlands; they experience the effects of upstream deforestation and sedimentation, but also pollution from agricultural and industrial waste. The other rivers, such as the Ramisi, draw their water from within the coastal region, catchments that appear less affected by these factors, so far (see chapter 4). However, some rivers that used to be permanent have now become seasonal in nature, probably as a result of the upstream felling of trees and cultivation of river borders. The major creeks, such as Mombasa, Mtwapa, and Kilifi have deep water anchorage. Other creeks such as Mida and Takaungu are shallow and fall largely dry at ebb tide. The brackish bottoms of the creeks and bays (such as in Gazi) offer suitable habitat for mangroves.

The mangrove ecosystem consists of tree canopy, mud environment and flood channels. There are eight mangrove species in Kenya which occur in fringe mangroves or as developed forests in creeks or bays; in the latter case, often with zonation by species (Ruwa, 1996). By 1980, Kenya had an estimated 53,000 ha of mangrove forest according to an often quoted estimate (Doute *et al.*, 1981). The major concentration is in the remote Lamu District where two-thirds to three-quarters of the mangrove forest is situated although there is uncertainty about the actual areal. Ferguson (1996) estimated that the mangrove hectarage existent in Lamu District is larger, by about a third. By all accounts the mangrove forests are in decline because of loss of areal (see chapter 8) but also by a decrease in density and maturity of mangrove stands (see chapter 7). Mangroves are of ecological and economic importance and offer suitable habitat for fish, shellfish, insects, birds and mammals. It also produces fuelwood and timber for building and boat construction. Mangroves are in decline because of reclamation of land for other purposes (such as salt ponds, shrimp farms and tourist facilities); because of increased subsistence use as building material and firewood; and because of commercial, often indiscriminate, felling. Mangrove forests are gazetted under the Forest Act and permits are needed for exploitation. The surveillance capacity of the government, however, is limited and ineffective and, as a result, there is a lot of abuse of these regulations.

Remaining coastal forests in East Africa are estimated at about 3000km² of which about 660km² is situated in Kenya (Burgess *et al.*, 1996). The latter includes the Arabuko-Sokoke forest which covers some 420km² and is the largest single block of indigenous forest remaining in the East African lowlands. It consists of forest and woodland and mixed forest of different types and has great biodiversity, both as regards flora and fauna. Nearly

600 higher plant species have been identified together with many butterfly species and there is a concentration of rare birds (KIFCON, 1995). Shimba Hills Forest has an even greater biodiversity. The smaller *kaya* forests vary from a few hectares to over 400ha in size and their current number is estimated at 40 (Githitho, 1997). In the past they have been protected as sacred places and burial grounds by the local population. Because of the demand for arable land and forest products both the large forests and the *kayas* are under threat. Also threatened are some of the rare birds that find a habitat there (see chapter 9).

History and Population

The coastal region has a long cultural history. Arab trade and settlements were already under way around the millennium. Arab and Swahili settlement have left traces all along the Coast. There are ruins in Gede and Jumbe, settlements that were probably deserted because of shortages of drinking water. A Chinese envoy visited Malindi early in the 15th century (Martin, 1973). Portuguese explorers reached Mombasa in 1498 leading to intermittent occupation until the end of the 18th century. At the beginning of the 19th century the Sultan of Oman moved his court to Zanzibar and established suzerainty over a narrow strip along the East African Coast. The coastal strip in Kenya remained nominally under the Sultan of Zanzibar but effectively the British administered this part of the country since the end of the 19th century. In 1963 this special status came to an end and the region joined the rest of Kenya at Independence.

Coast Province has the third area of population concentration in Kenya, after the Central and Western regions of the country, with 1.8 million inhabitants in 1989 (CBS, 1994). Kwale, Kilifi, Malindi and Mombasa Districts account for almost 80 per cent of the population. Together with the lower part of the Tana River and the sparsely populated Lamu District, they form the coastal region. Taita-Taveta and the upper part of Tana River are situated inland. The economic development of the region has not kept pace with other parts of Kenya. Coast Province scores comparatively low on development indicators such as child mortality, childhood malnutrition and literacy rate. Living conditions in large parts of the province are harsh and estimates place the incidence of rural poverty at forty per cent which is higher than in Kenya as a whole (Hoorweg *et al.*, 1995).

The main African population, the Mijikenda, originate from southern Somalia. According to oral tradition, they started to move into the region at the turn of the 17th century although there now appear to be indications that their presence dates from much earlier (Helm, personal communication). Settling in fortified hill-top villages, *kayas*, they

changed to a more dispersed form of habitation in the nineteenth century (Spear, 1978). By that time, the lands in the coastal plain were mainly in the hands of resident Arabs and Swahili who had developed large plantations (Cooper, 1981). After the abolition of slavery, this plantation economy declined and many Mijikenda joined ex-slaves living on unproductive plantations. As part of the transfer arrangements leading to Independence, the existing - often dormant - land rights of the Omani and Zanzibari owners were fully recognised by the newly independent government. Migration to the coastal plain increased further in the 1960s and many people settled on unused parts of estates or on state-owned land. Some of these lands later became official settlement schemes where land adjudication was done by the Government. Many people, however, remain squatters or are uncertain about the status of the land on which they live. At the same time there was in-migration from up-country groups such as Luo, Kamba and Kikuyu seeking employment and business opportunities. Effectively, there is also a floating population of European and American tourists numbering an estimated 50,000 annually (CBS, 1994).

As a result, the southern half of the Kenya Coast consists of a mixed population, more varied than elsewhere in Kenya with exception of the major towns, made up of Arabs, Swahili, Shirazi, Indians, Mijikenda (who are themselves divided in nine sub-tribes ² as the name says), other groups from the Northern Coast (such as the Bajun), up-country Kenyans, and foreign residents. Apart from economic and cultural differences, there exist profound religious and educational differences between these groups. Many observers have speculated about the causes of the lag in economic development of the region and the local attitudes towards economic initiatives and employment. Different causes have been postulated such as detrimental health conditions; poor educational levels that persist today; neglect by successive central governments; lack of economic drive; and cultural attitudes towards achievement. Another factor that is less often mentioned is nevertheless important in the coastal strip. Although the native Africans are the largest group, their settlement in the coastal strip post-dates that of some of the other groups and large numbers of them have no security of tenure. A transient attitude towards land is further enhanced by the extravagant prices that are being paid for land near the seafront or other places suitable for tourist development. Many people have no legal tenure and as likely as not have a family history of land dispossession. This has resulted in communities that are less cohesive than those situated inland, where *kayas* are good examples of community conservation although even here control appears to be breaking down (see p.10). By and

2. The most populous subgroups are the Giriama, Duruma and Digo followed by the Chonyi and Rabai. Quite small in number, yet culturally distinct, are the Kauma, Jibana, Kambe, Ribe.

large, in many parts of the coastal strip, community control over common resources is poor and this allows all kinds of political and economic manipulation.

Because of this combination of political, educational and other factors, the local population has, on the one hand, a deep rooted suspicion of outsiders, particularly outsiders who take economic or, for that matter, environmental initiatives. On the other hand, if approached convincingly enough by their leaders, they are easily swayed into exploitative ventures for relatively little reward often against their own long-term interest. This has led to a curious state of suspicion and apathy on one hand, and political manipulation and economic exploitation on the other hand. Mostly, however, a state of indifference prevails, in which neither economic opportunities are taken up, nor strong forces are developed for resource conservation.³

Environmental Priorities

The coastal environment is threatened by naturally occurring processes, growing subsistence needs of the population, and increased economic exploitation. The national plan lists the following coastal and marine issues for environmental action: silt and sewage threats to reefs; overexploitation of reef fisheries; overharvesting of mangrove trees; domestic and industrial pollution; sewage and waste disposal; management of fresh water supply; and salination of groundwater (MENR, 1994).

Coastal erosion and increased sedimentation (particularly of the Sabaki River, the last stage of the Athi-Galana river system which flows through some major population areas) are examples of natural processes that affect the coastal environment. The increased impact of sediments and pollution are having adverse impacts on marine flora and fauna, in particular, the coral reefs are being threatened by siltation. The increased sedimentation load, on the other hand, has also resulted in the expansion of the dune fields near the mouth of the Sabaki River (see chapters 2 and 3). Coastal erosion affects man-made structures but also threatens habitats of certain marine organisms. Together these factors pose threats to the biodiversity of the estuarine and coral reef ecosystems.

The coastal region lacks adequate water resources and is a net importer of water; there is scarcity for domestic, industrial and agricultural use. Piped water is drawn from Mzima Springs and the Sabaki River but the infrastructure is obsolete and suffers frequent breakdowns. As a result, many boreholes have been sunk with heavy consumption of groundwater. Water quality is threatened from at least two sides, namely overexploitation (see chap-

3. This was written before the recent outburst of violence in August '97.

ter 6) and increase in population combined with poor sanitation (see chapter 7). As a result, where water is present it is often contaminated, polluted or saline. Microbial contamination is one of the main causes of water borne diseases. Pollution of surface water is also a concern. The national scarcity of energy also affects the coastal areas with frequent breakdowns and even rationing of electricity and consequent environmental problems arising from the use of conventional energy sources. The high rate of charcoal production that reportedly exists in the hinterland requires attention.

Domestic and industrial waste pose increasing problems. Domestic sewage contributes about 10-20 per cent to pollution loads, and industrial effluents account for 50-60 per cent. Most sewage is produced in Mombasa which accounts for more than 70 per cent of pollution loads. Waste management systems in Mombasa are largely dysfunctional: it is estimated that only 60 per cent of domestic garbage is collected; the sewage treatment system is absent or non-operational (Munga *et al.*, 1993). There is also the impact of industrialisation in the rural areas. For example, mining and extraction industries are heavily polluting or damaging e.g., a local cement factory with severe aerial emissions; a local calcium factory using mangrove wood as energy source; and local sand mining which threatens the water table.

In the inland areas, households rely on crop cultivation, livestock and off-farm employment; and environmental issues centre around problems arising from rural development in marginal areas. The effects of heavy land use are increasing, notably the high rate of charcoal production, overgrazing and erosion. In the coastal strip, apart from agriculture and employment, a substantial though unknown amount of income is derived from exploitation of coastal resources; notably fishing, other aquatic activities, mangrove harvesting and the tourist industry. Because of its combination of tropical climate, natural treasures and historical sites, the region attracts heavy tourism. In 1993, beach hotels accounted for more than 60 per cent of all bed-nights in the country and this figure has been increasing (CBS, 1994). Coastal tourism is mainly limited to the coastal strip and the sea front which places a heavy burden on the reefs and beaches (Visser & Njuguna, 1992). Tourism-related activities such as hotel construction, furniture making and curio production use large numbers of hardwood trees and mangroves.

Population increase is tied in with growing commercial exploitation. This concerns, particularly, mangrove forests that are being overexploited; overfishing with the result that, at the very least, individual catches are going down; logging and cutting of saplings which threaten forest resources; and sand and soil harvesting without subsequent rehabilitation. Although these activities may provide a source of income or employment for the local

population, the main proceeds of these economic activities are probably going elsewhere. Several of these resources are finite and if current trends of exploitation continue unchecked they will not only be exhausted but certain aspects of the coastal environment will suffer irreparable damage.

Environmental Management and Research

Over the past decades, there has been an increased environmental concern for coastal areas everywhere. Coastal zone management, the sustainable use of coastal resources, is now high on the international agenda. In Kenya, the first integrated management and action strategy was developed in 1996 for Nyali-Bamburi, an area of heavy tourist concentration, north of Mombasa. The plan was drafted by a team consisting of six governmental and non-governmental organisations and identified a number of priority areas requiring action: land use; water supply; fisheries; and critical habitats such as mangroves, coral reefs and beaches (ICAM, 1996). Because of the nature of the selected area, this plan focused on containing the environmental effects of heavy tourism. Environmental concerns elsewhere in the Coast are the responsibility of the Provincial Administration, the Ministry of Environment and Natural Resources, various line ministries, local authority and parastatal organisations. A number of research organisations have an active presence as well. The main actors are briefly outlined below; smaller organisations and projects also exist which have more restricted objectives.⁴

The District Environment Officers come under the Office of the President. They are District Officers charged with the environmental co-ordination of government departments, non-governmental organisations and various interest groups. They are also expected to organise action in case of environmental problems that come to the fore. This requires mobility and expertise to be able to monitor ongoing issues but reality is different. The Environment Officers are often ill-equipped, particular as regards transport (Munga'sia, 1997). Sometimes, they are responsible for more than one district. They need training but they are also in need of neutral advisors as well as supporting research.

The Coast Development Authority (CDA) is a parastatal corporation charged with development planning and co-ordination for the region but also facilitating individual projects. One important responsibility is the monitoring of extraction and use of natural resources, especially mining, water catchment and soil conservation. CDA has taken a lead role in the first attempt at integrated coastal management (Mwandotto, 1997).

Kenya Wildlife Service (KWS) is an important organisation since there are five Marine

4. More information about environmental management, research and training is presented in Hoorweg (1997).

Parks and six Marine Reserves that cover about 100km sea front in all.⁵ It also plays a major role in raising public awareness of conservation and protection issues. KWS has recently established a marine research unit in Mombasa that has as priority subjects marine resources, endangered species, pollution and resource exploitation (Muthiga, 1997).

Kenya Marine and Fisheries Research Institute (KMFRDI) is also a national organisation; it has a mandate to undertake research and advise on the state of aquatic resources and the environment. It has established eight research centres throughout the country with the largest, for marine and coastal waters, in Mombasa. The primary focus is on assessment of existing fish stocks and determination of sustainable exploitation levels. Apart from fisheries, subject areas are marine organisms, mangroves, resource exploitation, and marine pollution (Wakwabi, 1997). Mention also can be made of the Coral Reef Conservation Project which focuses particularly on the impact of human activities on coral reefs and that has a research and training programme in place.

The National Museums of Kenya (NMK) have an interest and expertise in biodiversity research. Together with KWS and the Forest Department, they are involved in research and conservation of the lowland forests. The National Museums have hosted, in some form or other, activities such as the Kenya Indigenous Forest Conservation Programme, Centre of Biodiversity, Kenya Resource Centre for Indigenous Knowledge, Birdlife International and other individual projects (Robertson, 1997). Of late, the traditional conservation of the *kayas* by the elders appears to be faltering and these forest patches are threatened by logging activities and encroachment by the population. The Coastal Forest Conservation Unit, is a recent NMK-project to protect the *kayas* by means of gazettelement of these forests as National Monuments as well as strengthening traditional protection and offering alternatives to over exploitation (Githitho, 1997).

School of Environmental Studies

Moi University, School of Environmental Studies (MUSES), has a national mandate for research on sustainable resources in Kenya and to assist in policy formulation that encourages friendly exploitation of resources. At the start, in 1984, the emphasis was on postgraduate teaching at M.Phil. level, but in 1995 the programme expanded the number of M.Phil. admissions and started a D.Phil. programme. Research activities will focus on three areas: (i) Moi University campus surroundings, south of Eldoret; (ii) Homa Hills Field Research Centre near Lake Victoria; and (iii) Coast Environment Research Station in

5. Marine Parks are situated at Malindi, Watamu, Mombasa, Kisite and Mpunguti. Marine Reserves are at Kiunga, Malindi, Wakamu, Mombasa, Diani/Chale and Mpunguti. Terrestrial Parks and Reserves in the coastal area are: Shimba Hills, Doodori, Boni, and Tana River Primate Reserve.

Malindi. For its coastal programme, MUSES has identified eight research themes that have to provide scientific information for planning and management purposes: water & energy resources; land use & human settlement; coastal resources exploitation; public health & environment; tourism & environment; biodiversity & ecosystem dynamics; oceanography; and environmental legislation & enforcement (MUSES, 1997a).

The Coast Environment Research Station (CERS) in Malindi was started in 1996 to liaise with other coastal organisations concerned with environmental issues (MUSES, 1997b). The main objectives of the station are facilitating research, organising conferences/seminars, and publishing and documentation. Malindi was selected as a base for activities for several reasons. Firstly, because of the environmental richness within the Malindi vicinity: Malindi & Watamu Marine National Park with extensive coral reef formations; the Sabaki River estuary including the Mambrui sand dunes; the Arabuko-Sokoke Forest harbouring unique plant and animal species; and the Mida Creek Marine National Reserve with extensive mangrove forests. Secondly, Malindi is situated at the edge of the fertile and populated coastal strip and the drier north, along Ungwana Bay and the Tana River, giving easy access to different habitats. Thirdly, land has been acquired on the southern bank of the Sabaki River. This land has a varied habitat consisting of sandy dunes, mangroves, low lying riverside and higher old dunes. Construction of a field station is in progress that will provide accommodation for visiting scholars together with modest laboratory and lecture facilities.

Post-Graduate Research

Research before 1996 was concerned with sedimentology, dune vegetation, groundwater, mangroves and birdlife in different locations in the coastal strip areas of Kwale, Kilifi and Malindi District (Fig 1.1). So far, seven M.Phil. studies and one Ph.D. study have been completed. Abuodha and Musila worked on sediments and dunes of the Sabaki River; Munyao studied sediments in the Shirazi-Funzi Lagoon in the far south. Anyango and Mzuga studied groundwater in Kwale District; the former in relation to sea water intrusion, the latter in respect of water quality and contamination. Ouko and Kamau were concerned with mangroves, the first assessed the condition of mangrove swamps with different degrees of exposure to human exploitation, the latter studied biological aspects of mangrove conservation and regeneration in Ngomeni. Matiku selected Arabuko-Sokoke Forest where he studied one of the threatened bird species. The respective theses were rewritten during a workshop in Mombasa from 7-15 August, 1996, organised for that purpose and the resulting papers constitute this monograph.

Figure 1.1 Map of Southern Kenya Coast with study locations

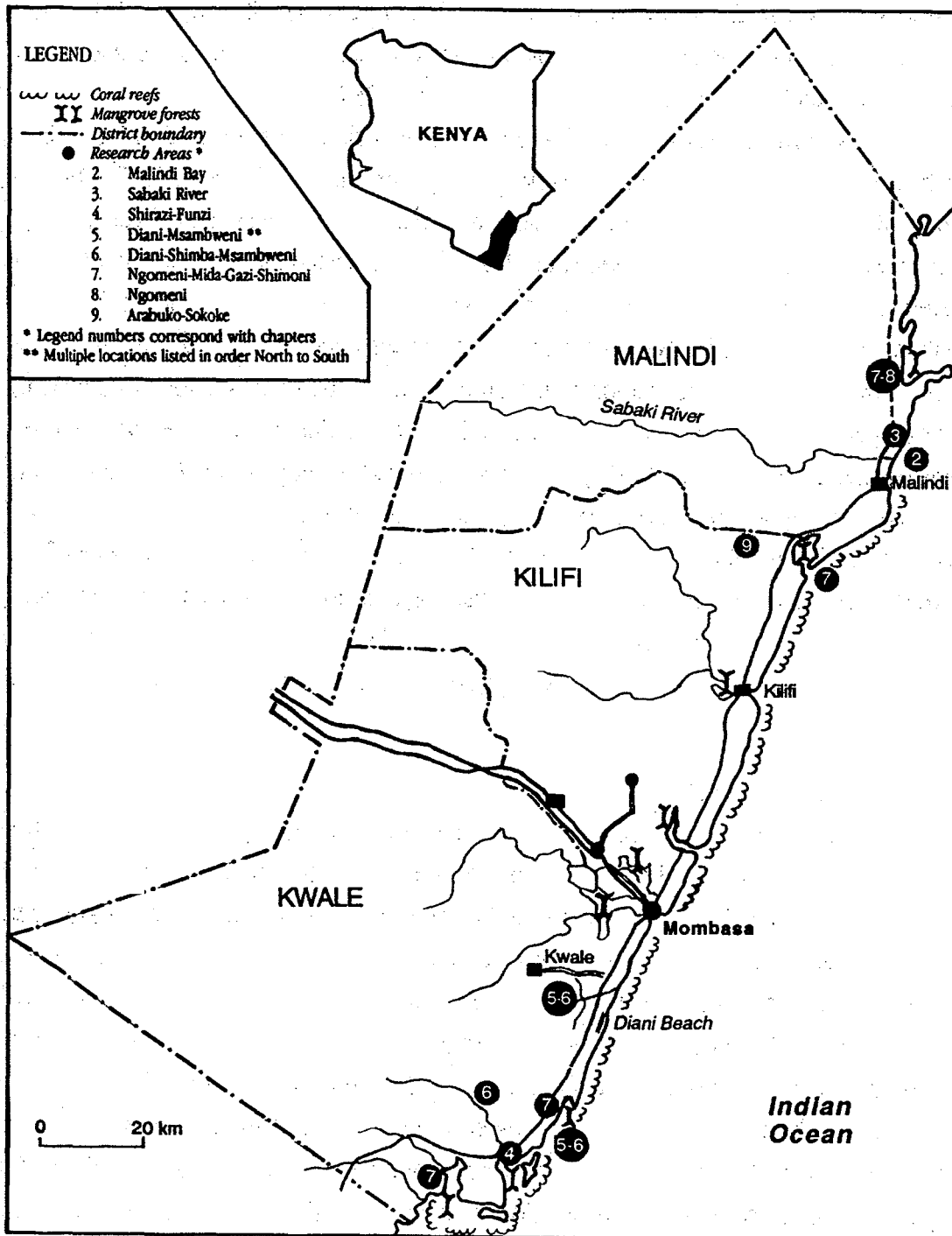

The physical characteristics of Malindi Bay are reviewed by Abuodha (Chapter 2). Oceanographic and meteorological factors are discussed, notably the effects of the alternating monsoons in conjunction with the East African and Somali Currents as well as the tidal patterns. Geographical and geomorphological characteristics are reviewed and the major coastal events and morphological developments are dated against Holocene and Pleistocene periods. The chapter pays particular attention to dune formation and coastline movements. Since the 1960s, the coast of Malindi Bay has experienced considerable shoreline movement and a large dune field has developed. The most likely cause is an increase in sedimentation of the Sabaki River. As a consequence, the agricultural lands, recreational facilities, and settlements next to the mobile sand dunes are threatened. The process is furthered by devegetation of stabilised dunes through overgrazing and clearing.

Coastal dunes receive, store and release excess beach sand. The dunes act as a buffer against storm waves and winds. In addition to absorbing the force of the waves, the dunes shelter communities land inward and assist in the retention of freshwater tables against saltwater intrusion. They are also important as nature reserves. Dune vegetation plays a vital role in the growth and stabilisation of dunes since it grows with the developing dune and regenerates when the dune is damaged. The root system and vegetation is capable of binding loose sand but when the mantle of vegetation is broken, dune movement can be accelerated to a point where plant growth cannot keep pace with the shifting sand. The study by Musila describes the composition, structure and distribution of the dune vegetation and the factors which affect its distribution (Chapter 3). More than 150 plant species were recorded on the dunes next to the Sabaki River. Fifteen plant communities were identified in nine geomorphological units with a distinct zonal distribution of the plant communities.

The Shirazi-Funzi Lagoon, in the South, is one of the shallow bays along the Kenyan Coast. It is fed by the Ramisi River and has important mangroves and fish breeding grounds. Cliffs, beaches, channels, sandbars and mangrove islands are the main features of the lagoon which is dominated by terrigenous sediments, comprising mostly of fine quartz sand. Munyaio studied the extent to which sedimentation poses an environmental threat to this particular ecosystem (Chapter 4). This study also assessed the main socio-economic activities in the lagoon, fisheries and mangrove exploitation.

Due to regular water shortages from the main water system there is increasing use of groundwater with a danger of overexploitation and possible seawater intrusion. Anyango studied this issue in Kwale District in an area which hosts many tourist hotels but where there is also an extensive network of shallow boreholes for the rural population and he did

find confirmation that sea water is intruding further (Chapter 5). Extraction, however, is not the only danger to water quality. Another danger follows from increased population density and poor sanitation. Mzuga studied the pollution of groundwater in a sandstone aquifer and coral stone aquifer, comparing samples from boreholes, wells and springs (Chapter 6). The waters found in the sandstone area are still potable and generally useable for most domestic and livestock purposes but this is not the case for the coral stone area. All the wells and springs that were sampled were contaminated to a greater or lesser extent, something which needs urgent attention. Boreholes had the least contamination but there was a relation between degree of contamination and nearness of pit latrines.

Mangrove forests play a significant role in the coastal economy. Human exploitation, however, accelerated by a growing population, is causing changes in the biological diversity, zonation and structure of the natural ecosystem. Ouko studied the mangrove situation in four major mangrove stands in relation to nearby habitation and human exploitation (Chapter 7). Biological indicators, such as mangrove complexity and stand diameter, reveal a clear-cut order of mangrove development and maturity, starting from Shimoni which appears least affected, to Mida Creek, Ngomeni and Gazi which is most affected. Different species of mangroves, however, appear differently affected by the harvesting by local people and by licensed operators. The latter, whether licensed or unlicensed, increasingly resort to uncontrolled cutting and even clear-felling.

Kamau compared the current status and extent of mangrove forests vis-a-vis that in the 1960s and further focused on the biological aspects of mangrove conservation and regeneration (Chapter 8). He studied macro flora and macro fauna of mangrove forests at Ngomeni, and the physical and chemical properties of the soils. His conclusion is that mangrove forests are being over-exploited, and that the hectarage has been decreasing because of the expansion of aquaculture and saltworks, and because of uncontrolled exploitation to provide timber, poles, and firewood. This has led to a decline in forestry productivity and macroinvertebrate species diversity, and has led to changes in physical and chemical properties of the soil. Rehabilitation conservation, and sustainable utilisation of the mangrove forest resources is still possible.

Terrestrial forests, like the mangroves, are also threatened by overcutting and logging. Matiku studied how this threatens the fauna, in this case the East African Akalat, a bird that is restricted to a few sites on the East African Coast (Chapter 9). The best predictors for Akalat presence were mossy logs and vegetation cover at low height; while sites without Akalat had higher numbers of cut stems. This indicates that human activities (i.e., logging and collection of dead wood) affect the population density and distribution of the Akalat

by affecting vegetation structure suitable for this bird. Urgent measures to provide alternatives to fuelwood need to be addressed to lower the illegal exploitation of trees which continues largely unhindered.

References

- Burgess N, Fitzgibbon C D & Clarke P (1996). Coastal forests. In T R McClanahan & T P Young (eds). *East African ecosystems and their conservation*. New York: Oxford University Press. pp.329-359.
- CBS (1994). *Statistical abstract*. Nairobi: Central Bureau of Statistics.
- Cooper F (1981). *From slaves to squatters: Plantation labour in the development of smallholder agriculture*. New York/London: Praeger Publishers.
- Doute R N, Ochanda N & Epp H (1981). *A forest inventory of Kenya using remotes sensing techniques*. KREMU Technical Report no.30. Nairobi: Kenya Rangeland Ecological Monitoring Unit.
- Ferguson W (1996). A land(scape) ecological survey of the mangrove resource of Kenya. Unpublished report.
- Frazier J G (1993). Dry coastal ecosystems of Kenya and Tanzania. In E v.d. Maarel (ed.). *Ecosystems of the world*, Vol. 2B: Africa, America, Asia and Oceania. Amsterdam: Elsevier. pp. 129-150.
- Githitho A (1997). Kaya forest conservation on the Kenya Coast. In Hoorweg J (ed.). *Environmental management, research and training in Coast Province, Kenya*. Eldoret: Moi University. Coastal Ecology Series No.1. pp. 45-48.
- Hoorweg J, Foeken D & Klaver W (1995). *Seasons and nutrition at the Kenya Coast*. ASC Research Series No.7. Oxford: Avebury.
- Hoorweg J ed. (1997). *Environmental management, research and training in Coast Province, Kenya*. Eldoret: Moi University. Coastal Ecology Series No.1.
- ICAM (1996). *Towards integrated management and sustainable development of Kenya's coast: Findings and recommendations for an action strategy in the Nyali-Bamburi-Shanzu area*. Narangansett/Mombasa: Coastal Resources Center/Coast Development Authority.
- Jaetzold R & Schmidt H (1983). *Farm management handbook of Kenya: Vol.IIC, East Kenya*. Nairobi: Ministry of Agriculture.
- KIFCON (1995). *Arabuko-Sokoke Forest and Mida Creek: The official guide*. Nairobi: Kenya Indigenous Forest Conservation Programme.
- KWS (1996). *Kenya: National Parks and Reserves Tour Planner*. Edition No. 11. Nairobi: Kenya Wildlife Service.
- Martin E B (1973). *The history of Malindi: A geographical analysis of an East African coastal town from the Portuguese period to the present*. Nairobi: East African Literature Bureau.
- McClanahan T R & Obura D (1996). Coral reefs and nearshore fisheries. In T R McClanahan & T P Young (eds). *East African ecosystems and their conservation*. New York: Oxford University Press. pp.67-99.
- MENR (1994). *The Kenya National Environment Action Plan: Report*. Nairobi: Ministry of Environment and Natural Resources.
- Munga D, Yobe A C, Owili M & Mwanguni S M (1993). *Assessment of land-based sources of marine pollution along the Kenyan Coast*. (Report for WHO Regional Office). Mombasa: KMFRI/Government Chemist.
- Munga'sia H (1997). District environment management. In Hoorweg J (ed.). *Environmental management, research and training in Coast Province, Kenya*. Eldoret: Moi University. Coastal Ecology Series No.1. pp.7-10.
- Muthiga N (1997). Kenya Wildlife Service, Marine Programs. In Hoorweg J (ed.). *Environmental management, research and training in Coast Province, Kenya*. Eldoret: Moi University. Coastal Ecology Series No.1. pp.21-26.

- MUSES (1997a). *Coast environment research priorities*. Coastal Ecology Series No.2. Eldoret: Moi University, School of Environmental Studies.
- MUSES (1997b). *Coast Environment Research Station: Annual Report 1996 and Development Plan*. Coastal Ecology Series No.3. Eldoret: Moi University, School of Environmental Studies.
- Mwandotto B (1997). Coast Development Authority. In Hoorweg J (ed.). *Environmental management, research and training in Coast Province, Kenya*. Eldoret: Moi University. Coastal Ecology Series No.1. pp.11-16.
- Robertson S A (1997). Priorities in botanical research in coastal Kenya. In Hoorweg J (ed.). *Environmental management, research and training in Coast Province, Kenya*. Eldoret: Moi University. Coastal Ecology Series No.1. pp. 35-43.
- Ruwa R K (1996). Intertidal wetlands. In T R McClanahan & T P Young (eds). *East African ecosystems and their conservation*. New York: Oxford University Press. pp.101-130.
- Spear T T (1978). *The Kaya complex: A history of the Mijikenda peoples of the Kenya coast to 1900*. Nairobi: Kenya Literature Bureau.
- Stuart C & Stuart T (1995). *Africa: A natural history*. Cape Town: Southern Book Publishers
- Visser N & Njuguna S (1992). Environmental impacts of tourism on the Kenyan Coast. *UNEP Industry and Environment*, 2, 42-51.
- Wakwabi E (1997). Maritime Research Priorities for Kenya Marine and Fisheries Research Institute. In Hoorweg J (ed.). *Environmental management, research and training in Coast Province, Kenya*. Eldoret: Moi University. Coastal Ecology Series No.1. pp.17-20.

2

GEOLOGY, GEOMORPHOLOGY, OCEANOGRAPHY AND METEOROLOGY OF MALINDI BAY *

J. ABUODHA

Introduction

Malindi Bay covers the area between Ras Ngomeini Peninsula in the north and Leopard Point in the south, a shoreline of about 45 km. It encompasses the townships of Malindi and Mambui and the Sabaki River estuary. The earliest geological work in the Malindi area involved geological mapping by Thompson (1956). In 1968, the United Nations assigned the Delft Hydraulics Laboratory (Delft Hydraulics, 1970) to investigate the causes of the increased siltation from the Sabaki river in Malindi Bay and on the beaches of Malindi. Their main aim was to propose measures for counteraction and protection of the Malindi beach. They conducted echo sounding to determine reef levels and depth in the offshore

* This paper is a revised version of a chapter in the forthcoming Ph.D. thesis by the author.

area. The data collected were on near shore currents and wave patterns. This study also included feasibility site investigations for the proposed harbour at Malindi. Schroeder (1974) conducted reconnaissance fieldwork on the sedimentology of the Malindi coast and shelf environments.

During the survey trips of RV Ujuzi, in the period between 1979 and 1981, oceanographic data were collected by the Kenya Marine and Fisheries Research Institute (KMFRI) in the area covering Malindi Bay and Ungwana Bay. These investigations were performed to determine the nature of the Somali Current. Extensive data on ocean current speed and direction were collected. These data have been given in project work reports no. 1, 2 and 3, respectively for the survey activities in 1979, 1980 and 1981 (KMFRI, 1981). Besides the data on current movements, climatological data with regard to wind direction and speed are also included; part of the data has been published by Johnson *et al.* (1982).

Hove (1980a) conducted some preliminary studies on sedimentation in the modern depositional environments of Malindi which included beaches and the Sabaki estuary. A brief description of the submarine geomorphology of the submerged continental margins was also incorporated. Halse (1980), a consultant geologist, was contracted by the Government of Kenya, Ministry of Environment and Natural Resources to determine the locations of heavy mineral deposits in the area stretching from Malindi to Lamu, and assess the viability of their exploitation. During the period ranging from 1974 to 1988, Oosterom (1988) carried out investigations on the soils and geomorphology of the south-eastern part of Kenya, including Malindi.

In the 1980s, a number of geological investigations were carried out, especially on the southern coast of Kenya. They are mentioned here because similar rock outcrops are present in the Malindi area. The studies mainly involved stratigraphy, palaeontology, structural geology, and coastal terraces in the context of the geological history of this area starting with the break-up of Gondwanaland to Quaternary events. Notable literature on these topics are Hove (1980b), Cannon *et al.* (1981), Ase (1981), Braithwaite (1984) and Rais-Assa (1988).

Information on seasonal movement of the suspended sediment plume from the Tana and Sabaki Rivers into Malindi Bay and northward to Ungwana Bay was presented by Brakel (1984). The decline of the Malindi reef complex mainly due to siltation was studied by Blom *et al.* (1985). This topic has recently been revisited by Obura (1996) who detected a correlation between the suspended sediment load of the Sabaki and the thickness of silt accumulation on the coral reefs. Abuodha (1989) studied the morphodynamics and sediment dispersion patterns in the near shore area causing the segregation and deposition of

heavy minerals in the beach area between Malindi and Fundisa.

In 1993, during the Kenya-Dutch Expedition aboard the RV Tyro (in which this author participated) in the western Indian Ocean, the physical, chemical, biological and geological aspects of the marine environment were documented. Wave climate characteristics based on information gathered by ships of passage from 1949 can be retrieved from the Meteorological Office and Main Marine Data Bank (1990) in London.

Data on the Sabaki river flow discharge rates has been collected by the Ministry of Water Development from the 1960s. More recently, Mwongela (1996) has done studies on the physical-chemical parameters that control vegetation distribution in the Malindi Bay sand dunes. Besides the aforementioned, some pertinent information on the historical changes of the coastline over the past 40 years can be obtained from a series of aerial photographs dating from 1954 to 1994.

Oceanographic and Meteorological Factors

The coastal belt of Kenya experiences an equatorial (tropical) monsoon climate with south-east trades prevailing from April to October and north-east monsoon from November to March (Kenya Meteorological Department, 1984). The duration of the transition period varies from year to year although Johnson *et al.* (1982) have suggested that the switching takes place within 10 days during which the directions are variable. KMFRI (1981) recorded that wind direction, both in 1979 and 1981 changed in March to a southerly direction while in 1980 this happened in April. In November, at the start of the north-east monsoon period, the wind changed its direction to north-easterly. Gales are rare, but tropical storms may occasionally reach the coast. Findlater (1973) concluded that the winds are controlled in the main by low-level air current with a well-defined core in the western periphery of the Indian Ocean. Charts prepared by the Meteorological Office and Main Marine Data Bank (1990) based on long-term observations show that the winds blowing from the sea develop a dominant component that is almost parallel to the coastline and that the average strength of the south-east monsoon is greater than the north-east monsoon (Fig 2.1). The coastal wind system is influenced by a land breeze which develops at night and a moderate sea breeze towards midday, reaching its maximum during the afternoon. Wind speeds seldom exceed 14 m/s during both monsoon seasons. Gusts of 16 m/s occur locally and are most frequent in the transition months of March/April and October/ November (Mahoney, 1980).

A noteworthy feature of the offshore circulation are the major currents running parallel and close to the Kenyan coast, dominated by a constant northerly flowing (Fig 2.2) East

Figure 2.1 Wind rose for Kenya coast based on observations* by RV Ujuzi (KMFRI, 1981).

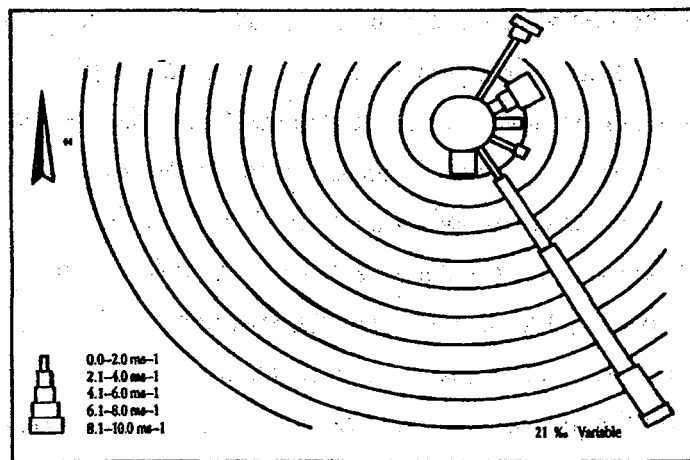

* Wind direction and force in Beaufort units. Beaufort force has been converted to ms^{-1} using a scale by McIlven (1992)

Figure 2.2 Currents off the Kenya coast based on observations* by RV Ujuzi (KMFRI, 1981).

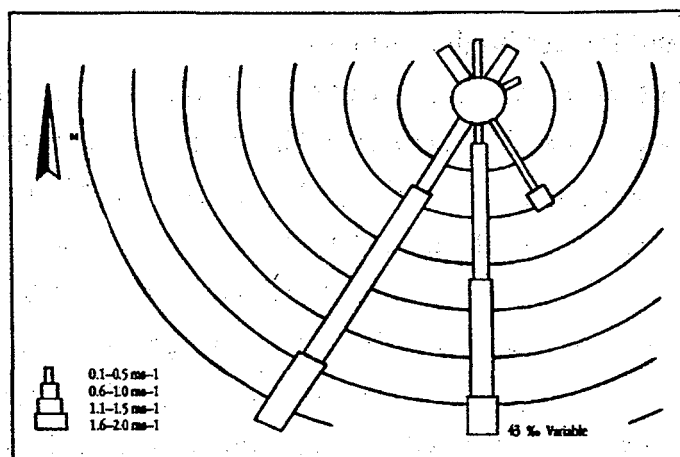

* Current speeds in knots have been converted to ms^{-1}

Figure 2.3 Wave characteristics and current movement off the Malindi coast, 1949-89.

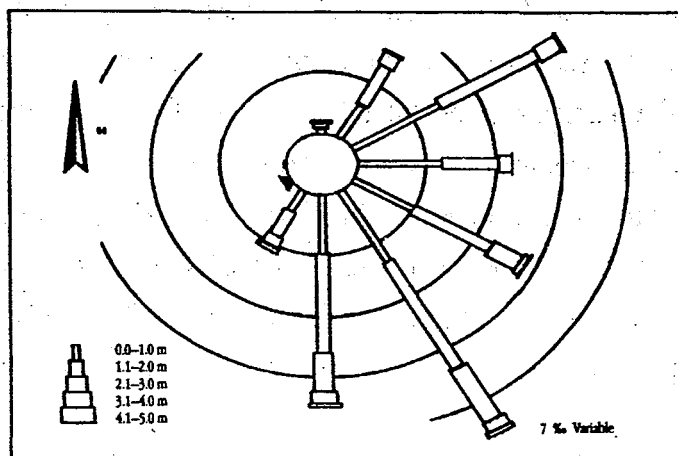

(Source: Meteorological Office and Maritime Data Bank, 1990)

African Coastal Current (E.A.C.C.). The south-east monsoon wind regime reinforces the northerly flow of E.A.C.C. which may attain speeds of about 1 m/s inshore and about 2 m/s offshore. The north-east winds not only work against the E.A.C.C. direction but also augment a southerly flowing current from the north, called the Somali Current. Though frequently strong, these currents are concentrated into narrow flows so that at more than 150 km from the shore, they are often quite weak. The annual variations in the speed and thickness of the coastal currents are only slight to the south of about 2°S. To the north, however, the Somali Current reverses in direction during the year in accordance with the monsoon wind regime and is therefore an example of a wind-driven western boundary current. In a model of the dynamics of western boundary currents, Johnson *et al.* (1982) have shown that the Somali Current penetrates some distance south before turning seaward at a zone also characterised by up welling. During unusually strong north-east monsoon it may penetrate as far south as Mombasa situated at approximate latitude 4°S (Williams, 1970).

From where the reversing Somali Current and the northward flowing East African Coastal Current meet (approximately 2°S) originates a seaward flowing current called the Equatorial Counter Current (E.C.C.). The position and timing of the switching action is probably triggered by a doming shelf topography known as the North Kenya Banks besides the actual influence of the wind field. It has been determined, however, that the switching of winds and currents is not exactly synchronous (Mahoney, 1980; Brakel, 1984). It was also observed that closer to the shore off Malindi Bay, at shallow depths of less than 100 m, the current direction was variable throughout the year, with a dominating southerly flow tendency (KMFRI, 1981). The author noted that monsoon winds did not seem to affect the current direction at the shallow part of the shelf and concluded that the water movement here is probably a mixture of the "escaping waters" out of Ungwana Bay, tidal currents and the flow of the Sabaki River.

The tides are semi-diurnal, falling within the meso-tidal range of 3-4 m. There seems to be a significant correlation between the occurrence of spring tide and neap tide on one hand, and on the other, the southerly and northerly drift of sediment plume which imply that the tidal currents may be effective within the littoral transport system. The strongest winds (8-14 m/s) are induced by the south-east trades. These generate large waves and swells. During this period, April to October, the coastal zone is also subjected to rare tropical storms with strength greater than 14 m/s. The dominant direction of waves breaking upon the beach is southerly (Fig 2.3), and about 70 per cent of the deep-water wave height at the breaker point is over 1 m (Bertlin, 1977). This season is also associated with cloudy and overcast skies. It is also noteworthy that during this period erosional scarps are

invariably evident over large sections of the coast. Light winds with speeds ranging from 4-6 m/s and smooth calm seas are representative of the north-east monsoon. Therefore, from November to March, the dominant direction of the breaking waves is from north-east (Fig 2.3) and about 45 per cent of them attain wave heights higher than 1 m. This is not surprising, because the winds are much weaker during the north-east monsoon. Based on ship data, Turyahikayo (1987) concluded that four wave regimes exist which include the two transition regimes when the wave directions are rather confused. Also important in this observation is that the March/April and November transitions involve a clockwise and anti-clockwise shifts respectively with significant reduction in wave strength. Observations from 1949 to 1989 show that heights above 1 m are the most frequent with an annual average of about 64 per cent (Meteorological Office and Main Marine Data Bank, 1990). The waves, carrying the sediment, release their energy at the breaker point and transmit shoaling waves towards the beach; this factor has important implications on the supply of sediment to the beach.

The coastal area has a humid climate with average rainfall of 1058 mm/year (Kenya Meteorological Department, 1984). There are two rainy seasons respectively referred to as the long rains and the short rains. The first wet months are April/May with over half the annual precipitation falling between April and June, during the south-east monsoon. This coincides with the penetration of a narrow zone of higher wind speeds across the Kenyan coast (Findlater, 1973). A study of statistical relationships between tropospheric winds and occurrence of rainfall over the western half of the Indian Ocean and East Africa has shown (Parker, 1973) that reduced wind strength due to upward advection is associated with the rainfall during May-October. The precipitation is usually concentrated in storms and showers. The second wet spell occurs during October/November when the air current begins to retract into the southern hemisphere and becomes markedly weaker. The total precipitation during this season is relatively small. There is no real dry season (with zero precipitation as long-term average) due to the effect of the Indian Ocean, although the potential evaporation averages about 1904 mm/year which is nearly twice the mean annual precipitation. The driest months according to climatological data (Kenya Meteorological Department, 1984) for the years 1949-1980 were January and February, with an average monthly rainfall of less than 20 mm and number of rainy days averaging two. The amount of rainfall seems to increase from north to south.

Monthly variations in air temperature from normal are slight, and closely related to the sea water temperature. From July to September the temperature average is 25°C, while in other months, it is from 27-28°C. Diurnal temperature variations are usually within the

range of 7-9°C, although the maximum and minimum temperatures recorded at the four coastal stations (Lamu, Malindi, Mombasa and Shimoni) are 36°C and 19°C.

The wind-wave environment and ocean currents are related to the beach-surfzone and dune morphology (Short & Hesp, 1982) and should be regarded as one unit and not in isolation. Additionally, wave energy reaching the shore was determined in the main by the strength, duration and fetch of wind blowing over the sea surface, and further influenced by attenuation and refraction across the continental shelf and near shore zones.

Continental Shelf

The continental shelf of East Africa is commonly narrow and its features are scantily documented. While some data on sounding are available on old bathymetric charts and even more recently by Johnson *et al.* (1982), a detailed description of the shelf features is not yet possible. During the RV TYRO Expedition covering the western Indian Ocean in 1993, the continental shelf topography was determined using seismic profiling and sediment distribution on the ocean floor mapped (Abuodha, in prep.). In the Malindi Bay area the width of the shelf is between 3 and 25 km, attaining its maximum width off Ungwana Bay. The shelf edge lies at comparatively shallow depths, mainly between 60-100 m.

The development of this shelf is connected with glacio-eustatic events and tectonic episodes since the Permo-Triassic period (Hove 1980a). It has been classified as an Afro-trailing edge type by Inman & Nordstrom (1971) and Shepard (1973). Along certain straight segments of the coast, the shelf is markedly absent, suggesting a fault origin. This occurrence is supported by a sudden drop of the sea-floor topography off the Kenyan coast which is attributed to the postulated Ruvu-Mombasa fault. This fault apparently maintains a NNE-SSW orientation throughout. Examination of bathymetric charts for the Kenyan coast indicate that indentations along the coast such as around the Ungwana Bay area are related to widening of the shelf, whereas narrow zones are generally associated with headlands and islands, for example, in the vicinity of Mombasa Island.

The continental slope is generally characterised by gentle gradients of about 1:20 to the shelf edge and shows dissected appearance probably due to previous sub-aerial fluvial action. This means that the continental slope was exposed when the sea level was so low (about 100 m below present) that fluvial action could affect the continental shelf, perhaps during the Mindel glaciation, i.e., Kamasian Pluvial using the East African pluvial terminology. This, in addition to coral reefs give it a rugged relief. In the northern sections, offshore sand bars or submerged ridges elongate parallel to the shoreline are superimposed on the gentle relief. The crests of these ridges may be partially exposed during low tide.

Also characteristic of the continental slope morphology are the marine terraces at about -8 m, and -35 m (Thompson, 1956) and -5 m and -15 m (Read, 1981) which probably correspond to levels of the shoreline during the various stages of eustatic decline.

Investigation of sediment distribution off the Kenyan coast during the Tyro Expedition of 1993 (Abuodha, in prep.) showed that in general, sand appears to be the principle constituent of the shelf floor, with mud dominant in the deeper water. In addition to bioclastic and authigenic carbonate accumulation, the Sabaki and Tana rivers also supply terrigenous material to the continental shelf, representing a zone of high sedimentation rates. The bioclastic component is mainly derived from the break-up of coral reefs. Thus the Malindi shelf with its bioclastic and terrigenous sources could provide a model for sediment mixing on a narrow continental shelf, which in combination with information on wind and wave climate would explain sediment budgets in the littoral and dune systems.

Sediment Sources and Supply

The Sabaki and Tana Rivers have a considerable discharge, 3.0×10^8 m³/year and 4.7×10^9 m³/year (Brakel, 1984) respectively and the terrigenous sediment load has dominated the development of the coast (Delft Hydraulics, 1970; Ojany, 1984; Abuodha, 1989; Arthurton, 1992). Recent reports suggest that the influx of sediment, particularly from the Sabaki River, has been on the increase and that sediment is spreading southward leading to active accumulation (Bird, 1985). The inlet in front of the Sabaki is characterised by the occurrence of spits, bars and offshore plume. In addition large submarine deltas have been formed which Hove (1980b) believed to be related to the salt-wedge effect.

Two sedimentological provinces are recognised along the Kenyan coast: north of Malindi the beaches and dunes consist of medium to fine terrigenous sand with small quantities of carbonate; from the Silversands Beach southward to Mombasa-Diani area the beach sands are mainly biogenic (Abuodha, 1992). The source of the terrigenous deposits composing the Malindi shores is the Sabaki river, in the south and probably the Tana river, in the north. Their mineral assemblage characterises the sediments as residues of disintegration of the Mozambican Belt metamorphic rocks drained by the upper courses of these rivers.

The Sabaki and Tana Rivers approach the coast in a narrow channel and a broad flood plain, respectively. The sandy shores near Malindi have their major part of the deposits derived from the Sabaki River (Abuodha, 1989; Abuodha & Nyambok, 1991) resulting from weathering of rocks inland. The Tana River system is connected with widespread deltaic environments dominated by silt/clay deposition (Ojany, 1984). It is also possible that the

ancient coastal formations such as the Mazeras and Mariakani sandstones which are incised by the Sabaki River channel provide an additional supply of sediments. Thompson (1956) and Williams (1962) have reported the presence of heavy minerals in these older formations which are also concentrated in modern-day beaches and dunes.

A recent study by Abuodha (1992) of beach deposits between Malindi and Shimoni in the south revealed that a great deal of carbonate sediments making up the beaches is derived from the adjacent reefs and cliffs. This is particularly so where the shoreline is bordered by fringing reefs. At Kilifi, Mtwapa and Mombasa creeks, the reef is interrupted by the outflow of fresh water and sediments from the local streams, the valleys of which are deeply incised into the coral limestone. The only minimal contribution of terrigenous material into the littoral system is these small streams which originate from the coastal Shimba Hills (Munyao, 1992). In the vicinity of the river mouths and creeks, the beaches consist predominantly of clastic materials but further away, carbonate content increases rapidly.

The clastic material transported by the Athi-Galana-Sabaki system is entrained by waves and currents which sort the material mainly according to size and density, such that the beach receives only the sand-size fraction and silt/clay-size fraction is transported offshore to form part of muddy shelf deposits. The sorting action by waves further causes enrichment of heavy minerals on the upper shore face (Abuodha & Nyambok, 1991). Micas are transported further than are quartz sands. The alternating tidal streams, in combination with the ocean currents and wave-induced long shore current is the major factor in sand distribution near the Sabaki delta. The contribution of each of these factors is a subject of further research, although initial observations show a dominance of tidal currents (Munyao, 1996). The winds are also affecting additional sorting on the berm and dune environments by the selective removal and redeposition of the lighter fraction in the prevailing wind direction.

Observations around Leopard Point reefs near Malindi and Watamu show that terrigenous sediment dispersal in the near shore area adversely affects coral reef development (Blom *et al.*, 1985; Delft Hydraulics, 1970; Obura, 1996). Hove (1980b) attributed the siltation problem of Malindi Bay to the southward sediment drift during the north-east monsoon coinciding with the main Sabaki floods. Analysis of Landsat imagery to depict seasonal dynamics of suspended sediment plumes from the Tana and Sabaki Rivers was carried out by Brakel (1984) who showed that a southward plume from the Sabaki River predominated during the north-east monsoons, while a northward plume dominated during the south-east monsoons.

Figure 2.4 Geological map of the coastal zone in the Malindi area

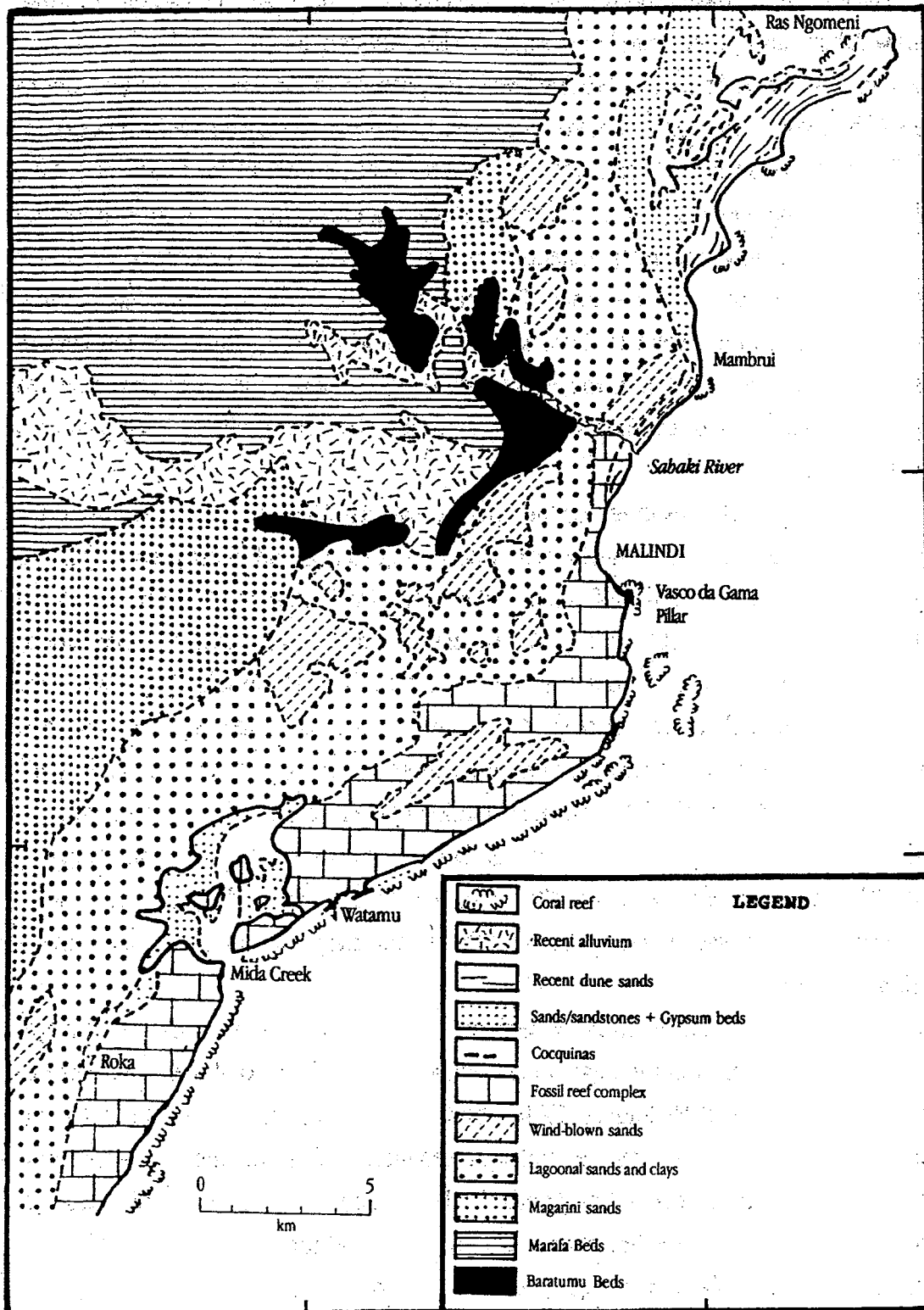

Source: Redrawn from Thompson, 1956

Clusters of heavy mineral placers containing economically valuable minerals are located north of Malindi, in the Sabaki River delta, in the neighbourhood of Ras Ngomeni Peninsula and on the beaches of Ungwana Bay barrier islands (Thompson, 1956; Abuodha & Nyambok, 1991). The detrital heavy minerals of Malindi and Ungwana Bay shores consist predominantly of titaniferous species (hematite, ilmenite and magnetite) with subordinate amounts of garnet, zircon and rutile. Monazite, augite, tourmaline and hornblende are present in negligible quantities.

Geological Setting

The East African coast is an Afro-trailing edge type (Inman & Nordstrom, 1971) which has experienced a general uplift since the Plio-Pleistocene. The southern Kenya coast consists of an assemblage of geomorphological and sedimentological features of littoral and aeolian origin, which show its past development through erosional and depositional sequences. In a broad sense, these fossil elements recorded suggest eustatic sea level oscillations and/or climatic change. Furthermore, isostatic and differential tectonic movements have considerably influenced the coastal configuration.

PALAEOZOIC- MESOZOIC ROCKS

The Paleozoic-Mesozoic outcrops (Fig 2.4), stratigraphy and plate tectonic processes of coastal Kenya have been described by Cannon *et al.* (1981) and Rais-Assa (1988) in relation to the rifting along the north-eastern part of Gondwanaland and the genesis of the proto-Indian Ocean. The vertical and horizontal movements associated with the break-up of Gondwanaland took place during the Permo-Triassic times and the ultimate marine incursion took place during the Jurassic (Kent, 1974). The underlying sedimentary sequence consists of the Upper Carboniferous Taru Grits overlain by the Permo-Triassic Karroo represented by the Duruma Sandstone Series (Caswell, 1956; Thompson, 1956). The Tertiary sediments are represented by the Baratumu Beds (sandstones with subordinate shales and limestones) of the Miocene and the Marafa Beds of the Pliocene and (Fig 2.4). The latter comprises sands and sandstones with subordinate shales and marls. Thompson (1956) dated them as Pliocene to Early Pleistocene based on the determination of fossil foraminifera. The Magarini Sands comprise unconsolidated quartzose sands which locally include gravels or clays and can broadly be subdivided into two different stratigraphic members. The Lower Member is formed by Plio-Pleistocene fluvial sands (Caswell, 1953; Williams, 1962; Oosterom, 1988). The Upper Member was distinguished in the Malindi area by

Table 2.1 *Chronology of the Pleistocene and Holocene events in the southern coast of Kenya based on earlier studies*

PERIOD	GENERAL PLEISTOCENE TERMINOLOGY	EAST AFRICAN PLUVIAL SEQUENCE	ALPINE GLACIAL SEQUENCE OF EUROPE	SEA LEVEL CHANGES	MAJOR COASTAL EVENTS AND MORPHOLOGICAL DEVELOPMENTS
HOLOCENE	Post-glacial	Post-pluvial	Post-glacial	Rise to present level	Silting up of Port Reitz and Port Tudor mangrove swamps; Sanddune formation
	Last glacial	Gamblian pluvial	Wurm glaciation	- 7.5m	Cutting of 7.5m terrace. Accumulation of Coquinas (aeolian sands) and raised alluvial deposits
	Last interglacial	Third interpluvial	Last interglacial (Eemian)	4.5m 9.0m	Formation of 4.5 m raised beaches, caves and platform; Temporary rise of sea level, cutting of 9 m marine platform
MIDDLE PLEISTOCENE	Penultimate glacial	Kanjeran pluvial	Riss glaciation	- 45m	Sea level regression and emergence; Subaerial erosion; Deposition of aeolian sands
	Penult. interglacial	Second interpluvial	Great interglacial	30m	Growth of coral reefs and formation of 30 m terrace
	Antepenultimate glacial	Kamasian pluvial	Mindel glaciation	- 60m	Marine regression to -60 m; Cutting of marine platform on which the coral grew; Cutting of Mwachi River deep channel at Kilindini; Deposition of Kilindini Sands, North Mombasa Crags and aeolian sands
LOWER PLEISTOCENE	Antepenultimate glacial	First interpluvial	First interglacial	60m	Accumulation of Magarini Sands
	Early glacial	Kageran pluvial	Gunz	?	
PLOCENE				90m	Deposition of Maraia Beds

Thompson (1956) as sands of aeolian origin. Both Caswell (1953) and Thompson (1956) considered them to be of Pleistocene age.

PLEISTOCENE AND HOLOCENE DEPOSITS

During the Pleistocene the Malindi coast was affected by global eustatic sea level oscillations which are reflected in its geomorphological and sedimentological features. The sequence of events that operated along the Kenyan coast and their equivalents in the Alpine glacial history of Europe are presented in Table 2.1. The existing correlations of Pleistocene sediments with particular sea level stands have been neither satisfactory nor unanimously accepted. The following account is based on Caswell (1956), Thompson (1956), Williams (1962), Braithwaite (1984) and Oosterom (1988).

Brief descriptions of the Pleistocene lithological units are given by Oosterom (1988) for the coastal rocks and unconsolidated deposits. In this stratigraphy three main types of Pleistocene formations are identified along the coastal plain from the west to the east. They are known as the Fossil Reef Complex, Lagoonal Sands and Clays, and Wind-blown Sands. The basement is probably a narrow wave cut platform paved on the underlying Cretaceous and Jurassic formations during the Early Pleistocene.

The Fossil Reef Complex consists of an assemblage of coral limestone, calcarenites and intercalations of quartz sands, sandstone pebbles, silt and calcareous algae. Outcrops of a Fossil Reef Complex formation are found between Shimoni in the south and the Ras Ngomeni peninsula in the north, a coastline distance of approximately 200 km. This reef formation extends 3-5 km from the present shoreline, underlying the coastal plain, and attains elevations of up to 30 m above sea level. However, Caswell (1956) determined from borehole records that the limestone may reach to a depth of 60 m below sea level, hence a maximum of about 90 m may be assumed for their thickness. The North Mombasa Crag, comprising of calcareous sand, shelly sands and clays (marls) are the sediments which form the foundation of the Fossil Reef Complex. This 'basal' unit has been interpreted by Braithwaite (1984) to be a product of mid-Pliocene crustal movements and considered to be of sub-aerial origin during a period of low sea level stand. Caswell (1953) recommended a Middle Pleistocene age for the Fossil Reef Complex by connecting the reef build-up with the second interpluvial (Table 2.2). In a later study of the Pleistocene limestones of the Kenyan coast, Braithwaite (1984) concluded that these deposits formed about 125,000 years ago when sea level ultimately stood 15-20 m above its present position.

Table 2.2 Correlation of the coastal terraces in southern Kenya according to earlier studies

STUDY AREA & AUTHOR, YEAR	SOUTHERN KENYA Sikes, 1930	MOMBASA AREA Caswell, 1953	MALINDI AREA Thompson, 1956	MOMBASA /MALINDI/ Bartistini, 1969	SOUTHERN KENYA Hori, 1970	SOUTHERN KENYA Toya <i>et al.</i> , 1973	MOMBASA AREA Ase, 1978	MOMBASA /MTWAPA/ Read, 1981	SOUTHERN KENYA Braithwaite, 1984	MOMBASA AREA Oosterom, 1988	AGE Oosterom, 1988
	75 m	Foot Plateau	Foot Plateau	Foot Plateau	Manuga Surface 80-120m	Marafa Terrace 80-120 m.				Cambini-I 85-130 m Cambini-II 70-90 m	950 000 BP 750 000 BP
	50 m	Foot Plateau	Foot Plateau		Changamwe Surface 45-70 m	Changamwe Surface 45-70 m				Tezo (I+II) 40-85 m	750 000 BP
	24m level	37 m Terrace	36 m Terrace	18-25 m Platform	Upper Mombasa Terrace 15-37 m	Ganda Terrace 20-37 m	VIII: 20m	Ganda Terrace 20 m	+20 m	Majaoni-I 35-50 m Majaoni-II 25-35m	650 000 BP 650 000 BP 475 000 BP
TERRACE NAME AND ELEVATION ABOVE DATUM	12 m level					Kilifi Terrace 15-18 m	VII: 17 m VI: 15 m V: 13.5 m	Kilifi Terrace 15-18 m		Mtondia-I 15-25 m Mtondia-II 10-15m	300 000 BP 180 000 BP
	9 m old sea beach	7.6 m platform	7.5 m beach terrace	7-10 m platform	Lower Mombasa Terrace 10m	Malindi Terrace 7-10 m	IV: 12 m III: 9 m II: 7 m	Malindi Terrace 7-10 m	+10 /12m +8 m	Mackenzie-I 8-10 m Mackenzie-II 6-8 m	130 000 BP
	4.5 m beach				Shelly Beach Terrace 5m	Shelly Beach Terr. 4.5m	I: 5 m	Shelly Beach Terr. 4.5 m	+6 m +4 m +2 m	Uhuru-I 4.6 m Uhuru-II 2.4 m	10 000 BP 0
Submarine terraces are present at -8 m and -35 m. (Thompson 1956) and at -5 m and -15 m (Read 1981)											

In the Malindi area, the Lagoonal Sands and Clays (Fig 2.4) correlates with the Kilindini Sands of Caswell (1953), the Pleistocene Sands of Thompson (1956) and the red sandy laterite of Braithwaite (1984). The sands comprise mainly quartz sands with subordinate silts and clays. Williams (1962) proposed a lower Upper Pleistocene age based on the presumed age of a terrace he identified at +12 m. The quartzose Lagoonal Sands and Clays deposits are considered to be contemporaneous with the Fossil Reef Complex, based on their fossil fauna (Caswell, 1953; Thompson, 1956). Due to the small extent of the local drainage basin, only covering the coastal zone, Caswell (1953) concluded that clastic sediments were derived from the nearby Duruma Sandstones of the Permo-Triassic and from the Early Pleistocene Magarini Sands. The fact that the Lagoonal Sands and Clays and coral reef formations are regarded as more or less contemporaneous suggests that the rate of clastic sedimentation was rather low since the corals flourished despite the siltation.

The Wind-blown Sands correlate with the Gedi Beacon Sands of Thompson (1956) and Pleistocene Dune Sands of Williams (1962). The latter has equated the three dune generations he recognised as isochronous with the cutting of the corresponding platforms on top of which they are placed, at 60 m, 36 m and 9 m respectively. Thompson (1956) also regards the Upper Pleistocene Sands and Gedi Beacon Sands in his sequence to be contemporaneous and coincident with the 36 m terrace. The suggested age of Upper Pleistocene by Thompson was based on the assumption that aeolian sands were derived from the continental shelf when sea level dropped from the 36 m terrace during that time. The cocquinas are prominently exposed at Watamu Beach, Vasco da Gama Pillar at Malindi and Ras Ngomeni Peninsula (Fig.2.4) and consists of wind-blown, carbonate-rich deposits, derived from beach materials, mainly shells. These aeolian deposits are strongly cross-bedded which led Thompson (1956) to misinterpret them as offshore bar deposits. A sporadic distribution of related dunes are present along the southern coast of Kenya. Ase (1981) has illustrated that the system continues northward into southern Somalia, a coastline distance of approximately 2000 km. Recent deposits comprise Recent Dune Sands, Recent Beach Sands and Tidal-Flat Deposits, and Recent Alluvium.

THE LATE QUATERNARY DUNE SEQUENCE

Williams (1962) and Oosterom (1988) have correlated the timing for the development of dune ridges in the Malindi area with that of marine terraces. Table 2.2 gives postulated episodes of dune development in the context of the Pleistocene and Holocene events, based on earlier studies. The Plio-Pleistocene Magarini Sands, whose Upper Member was distinguished by Thompson (1956) as aeolian deposits, is added to the three dune genera-

tions that were recognised by Williams (1962). According to a recent classification by Oosterom (1988) there are two additional dune generations which occupy the two Holocene levels. At Malindi, these dune generations are exemplified by a dune ridge with grey water repellent soils and the cocquinas between Watamu and Ras Ngomeni Peninsula. It is noteworthy that two of the dune generations overlie Williams' (1962) shore platforms at 36 m and 9 m. These shore platforms are equivalent in age and height to similar shore features where fossil corals at the base of dunes have separately been dated by $\text{Th}^{230}\text{U}^{234}$ to 240,000 BP and 130,000 BP (Braithwaite *et al.*, 1973).

In view of the above classification, recognition of at least six main phases of dune activity (dune generations) is possible. Quaternary eustatic sea level oscillations could trigger dune formation by increasing the mobility of shelf sediments whereas during low sea levels there would be a surplus of sand for feeding of the aeolian system. As mentioned before, dune formation is related to sea level fluctuations and sediment supply by rivers. Human activities, reactivation of existing dunes and morphodynamic transformations have also been cited in this regard. Both Hesp & Nordstrom (1990) and Orme (1990) have concluded that in Late Pleistocene and early Holocene times large amounts of sediment were exposed on the continental shelf. Then the disequilibrium conditions created by the post-glacial marine transgression, in combination with aeolian reworking, resulted in the accumulation of sand dunes. It is further speculated that when the sea level stabilised at about 7000 BP and a simultaneous reduction in sand supply prevailed, the dunes were stabilised by vegetation. If the radiocarbon dates given by Ase (1981) for the shore levels below 10 m datum are correct, then all Holocene dunes could be considered younger than 3000 BP.

There is sufficient evidence in the present area of dune remobilization during the Holocene to make them comparable with other studied cases world-wide (Pye, 1983 and Orme, 1990). However, there is also little consensus on the spatial and temporal effects of reactivation related to the Holocene. Data presented by Oosterom (1988) argues from evidence of aeolian reworking of beach ridges and foredunes that a dry phase is likely to have occurred at about 2200 BP. The falling sea level concept for terrace development could also relate dune formation to the same events. Retreating sea level exposes shelf deposits to aeolian activity, which may result in the consequent accumulation of coastal dunes. In this model, lower emergence rates are indicated by higher dune formations.

The youngest dune ridges are underlain by deposits of the Flandrian Transgression (Abuodha, 1989). A relict spit connecting the southern reach of the former extensive Ungwana Bay to form the Ras Ngomeni tombolo is actually the foundation upon which these aeolian sediments were deposited. The Sabaki River channel, incised into the Pleis-

tocene coral reef, can be considered to predate the formation of the terraces and their associated dunes. From this assumption, it is therefore inferred that this river has been the major source of beach and aeolian sand.

Geomorphological Setting

The Kenyan coast shows great diversity in the configuration of the shoreline consisting of sandy beaches, dunes, creeks, muddy tidal flats and rocky shores bordered by cliffs. In the Malindi area a detailed interpretation of sequential aerial photographs reveals that the coast here is depositionally emergent. In particular, the area has experienced a progradation of up to 750 m over the last 40 years. At a location next to a seaside resort (most likely the Gilani Beach), Bird (1985) reported beach progradation of up to 150 m between 1975 and 1981 alone, and attributed this to a southward long shore drift from the Sabaki delta in contrast to previous observations that indicated sediments drifted north toward Ras Ngomeni. Further north, Ojany (1984) has reported that the Tana River sediments have resulted in a progradation of the coastline near Kipini, and there has been an advance of the mangrove shores in the sheltered bays behind the Lamu archipelago. The northern coast is also characterised by a prominence of sand dunes and tombolos, exemplified at Ras Ngomeni, in addition to recognised higher land uplift and arching, all being features that indicate a shoreline of emergence. This is also supported by the fact that features like creeks are more common in the Mombasa-Kilifi area than in Malindi. The creeks should normally indicate a shoreline of submergence, but the submergence could have occurred earlier than the more recent emergence (Ase, 1981). Despite these observations, Oosterom (1988) has recorded deltaic features in the neighbourhood of the Lamu Archipelago that show evidence of submergence. Therefore, within the classification proposed by Johnson (1919), the Kenyan coast would be characterised as a compound-type coast, although individual segments may qualify as emergent or submergent coastlines. The Mida Creek, just south of Malindi, unlike similar creeks around Mombasa island, Mtwapa and Kilifi, shows no evidence of old river valleys, and it is therefore difficult to say that its origin is similar to the latter three localities.

There is a remarkable transition in coastal morphology north and south of Malindi. In the southern section, the coastal plain is 3-6 km wide and attains elevations of up to 50 m; its landward boundary is marked by the rise of the Foot Plateau, whose elevations range from 60-140 m. The landscape here is also characterised by a series of fossil dunes and marine platforms (terraces) which occur in decreasing height above MSL, down to the present

Figure 2.5 Geomorphological map showing terraces of the coastal zone between Kilifi and Gongoni

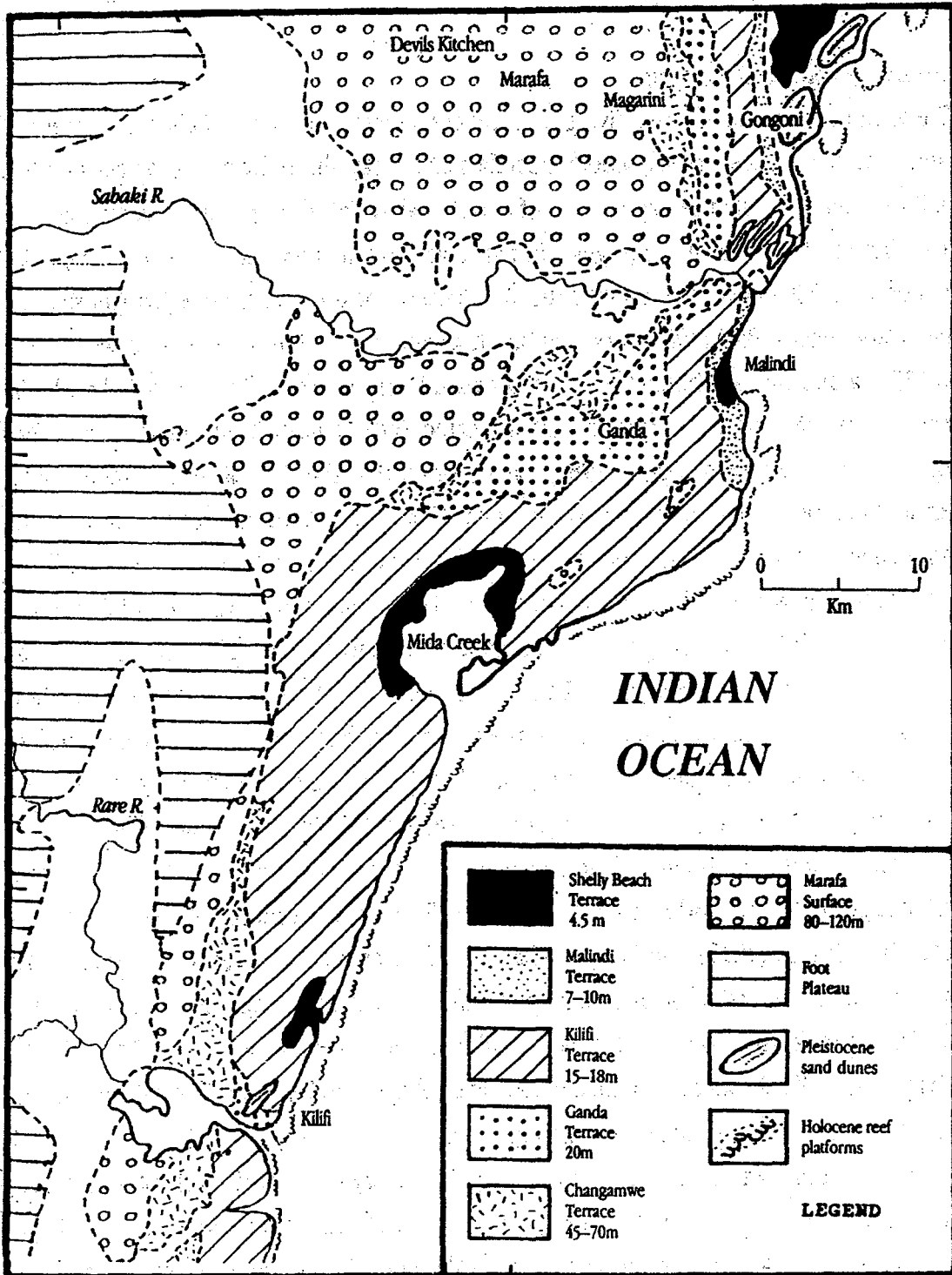

Source: Redrawn from Hori, 1970

beach and (even lower) the reef platform. At the end of this section more details on coastal terraces are given. The coastal plain is composed of emerged Quaternary coral reef rock, infilling into reef lagoons and channels, and of coastal sand dunes. These rocks form cliffs and an extensive reef platform on their seaward margin which is a prominent coastal feature from Vasco da Gama Point southwards to Shimoni. The cliff height is generally 10-15 m and is largely associated with elements of wave erosion leading to a slow but significant rate of retreat. However, for most of its extension, it is paralleled and protected by a fringing reef which abuts against the seaward edge of the platform. At some portions of the coast, pockets of beaches accumulate behind the fringing reef at the foot of the cliffs. Such examples of extended beaches are found at Diani and Kikambala. Occasionally, for instance at Shelly Beach, there are beach ridges or berms of recent origin. These isolated beaches are narrow and steeply inclined in more protected areas. North of Mombasa, near Nyali Beach, small sand dunes and offshore bars are characteristic features.

The tidal range and the position of the fringing reef platform concentrate wave action at two different levels. The lower level (reef edge) where waves break, experiences more intense wave abrasion, resulting in a rough surface with numerous small stacks and cavities. The upper level is characterised by weathered undercut cliffs with frequent caves or isolated beaches with beach berms. The distance from the shore to the outer reef edge varies from 1-3 km. Along the southern coast, the reef development is continuous except in the vicinity of creeks and estuaries. Geomorphological features of the coast around the Mombasa area were documented by Abuodha (1992).

The coastal plain broadens northwards, reaching widths of more than 50 km where the Tana and Sabaki (Galana) Rivers have deposited considerable amounts of sediments. The foreshore area between Malindi and Mambui generally consists of wide low-gradient extensive beaches. The Malindi beaches are characterised by runnel and swash bars which must be studied in detail to provide a better understanding of shoreline morphodynamics. There are also a series of low-lying subhorizontal berms on which aeolian processes are dominant. These are succeeded inland by an array of complex dune ridge systems of up to 50 m in height. The dune ridges in association with the raised reef flat are particularly prominent between the Sabaki mouth and Mambui. The dunes connected with the lowest coastal terrace are active and transgression over the older dunes is noticeable. The foredune development forms an intrinsic part of the dynamics of littoral-aeolian processes. The beach ridges, closely associated with the dunes are of variable Holocene age (Ase, 1981) and altitude. The stabilised foredunes north of Mambui, which fringe the landward side of the bays invariably show undercutting due to waves/wind erosion at the toe result-

ing in cliffs measuring about 1.0-1.5 m in height. The modern beach ridges are characterised by absence of vegetation and scattered pebble-size pumice particles.

Ras Ngomeni, a peninsula located about 20 km north of the Sabaki delta, consists of a small remnant of Pleistocene coral limestone linked by a spit deposit to the mainland, post-dated by dune development. The genesis of this feature is described in the previous section. In areas north of Ras Ngomeni (Ungwana Bay) different conditions prevail. Low coastal relief appears to be associated with tectonic subsidence and field observation shows that Holocene marine transgression has largely destroyed the older dune-barrier island systems. The area today is occupied by lagoonal flats subject to spring tide flooding via tidal channels. The low elevation shoreline sand bars or barrier islands constitute the active beach. Mangroves grow in muddy (tidal flat) or lagoon areas behind the dunes and barrier islands. A typical setting of this nature is found around the Robinson Island. Further inland, to the west of the bay, relics of the Quaternary dune sands occur as raised scrub covering an environment of low-lying lagoonal sand and clay flats.

The marine terraces of the coastal zone of Kenya (Fig 2.5) have been classified as the Marafa Terrace (+80 to +120 m), Changamwe Terrace (+45 to +70 m), Ganda Terrace (+20 to 37 m), the Kilifi Terrace (+15 to +18 m), the Malindi Terrace (+7 to +10 m) and the Shelly Beach Terrace (+4.5 m). However, it is only the lower four levels that are considered to have formed during the Pleistocene based on datings by Oosterom (1988). The present reef platform which is a prominent feature of this area occupies the level 2 m. It is, however, not possible using the available information to ascertain whether this marine terrace is of Pleistocene or Holocene, although Braithwaite (1984) gives the time of its formation to be 30,000 years ago when sea level paused at its present position.

Conclusion

Shorelines of many coastal areas are fringed landward by sand dune systems, though their occurrence and physical appearance depend on a combination of suitable factors. These are sand supply, wind regime, beach geometry, tidal range, precipitation, back shore physiography, vegetation and human activities. Sand dunes can be thought of as migrating bedforms resulting from wind action, and they can be stabilised by vegetation, which traps the moving sand and tends to bind it. They will, of course, develop only where the wind system is favourable, and large reserves of sand in the coastal zone and the beach sediments fall into the appropriate size range.

Bagnold (1954) and a host of other coastal geomorphologists have provided general explanations for dune formation. The clastic material that reaches the coastal region via the

mainland drainage system are worked over by waves and currents (sorting action). The resulting fine size material spread on the beach is picked up by wind and transported inland (aeolian transport). The abundance of fine size material together with the effect of moisture and vegetation are ideal conditions for dune building. According to this school of thought there should be a corresponding increase in the wind shear velocity to maintain sand transport. This is achieved by the adjustment of the bare sand surface into a dune form, especially if the sand laden wind encounters an obstacle. Jennings (1964) and Pye (1991) have suggested that coastal dunes are less likely to develop in the humid tropics, citing a plethora of climatic factors inhibiting their formation. The existence of such a large dunefield near Malindi is in apparent contradiction with the latter view.

Since the 1960s, the coast of Malindi Bay has experienced unprecedented high rates of shoreline progradation and a large transgressive dunefield has developed (Bird, 1985; Abuodha, 1989; Arthurton, 1992). The fundamental cause of this occurrence is considered to be an increase in sediment transport volume by the Sabaki River. As a consequence, the agricultural lands, recreational facilities, and settlements next to the mobile sand dunes are threatened with this incursion. The predicament is augmented further by anthropogenic influences such as devegetation of stabilised dunes through overgrazing and clearing. Thus the management of this area would require knowledge of morphodynamic processes operating, so that effective mitigating procedures could be implemented.

References

- Abuodha J O Z (1989). *Morphodynamics and sedimentology of the Malindi-Fundisa coastal area associated with the heavy mineral deposition*. M.Sc. thesis, Un. of Nairobi.
- Abuodha J O Z & Nyambok I O (1991). Petrology, geochemistry and evaluation of heavy mineral deposits, coastal Malindi and Ungama Bay, Kenya. *Marine Mining*, 10, 337-351.
- Abuodha J O Z (In preparation) Geomorphology and sedimentation of the nearshore areas influenced by Sabaki sediments: Implications for beach-dune interaction. Ph.D. thesis, Un. of Amsterdam
- Abuodha P A W (1992). *Geomorphology and sedimentology of the Mombasa-Diani area: Implications for coastal zone management*. M.Sc. thesis, Un. of Nairobi.
- Arthurton R S (1992). Beach erosion: Case studies on the East African coast. Paper presented at the BORDOMER 92 Workshop, *International Convention on Rational Use of the Coastal Zone*, Bordeaux, France. UNESCO/IOC REP., in press.
- Ase L E (1978). Preliminary report on studies of shore displacement of the southern coast of Kenya. *Geografisker Annaler*, 60A, 3-4, 209-221.
- Ase L E (1981). Studies of shores and shore displacement on the southern coast of Kenya- Kilifi District. *Geografisker Annaler*, 63A, 3-4, 303-310.
- Bagnold R A (1954). *The Physics of Blown Sand and Desert Dunes*. London: Methuen.
- Battistini R (1969). Le Quatenaire du littoral Kenyan entre Mombasa et Malindi. *Bulletin Association Francais, Etude Quatenaire*, 3, 191-201.

- Bertlin & Partners (1977). Wave records and analysis. East African Ports Development Study. *Kenya Ports*, 4, 180-182.
- Bird E C F (1985). *Coastline changes: A global review*. Chichester: Wiley and Sons.
- Blom J, Hagen H van der, Hove E van, Katwijk M van, Loon R van & Meier R (1985). *Decline of Malindi-Watamu reef complex*. Lab of Aqua. Ecol. Catholic Univ. 195.
- Braithwaite C J R, Taylor J D & Kennedy W J (1973). The evolution of an atoll; the depositional and erosional history of Aldabra. *Philosophical Transcript Royal Society, London*, 266, 1-32.
- Braithwaite C J R (1984). Depositional history of the late Pleistocene limestones of the Kenya coast. *Journal Geological Society, London*, 141, 685-699.
- Brakel W H (1984). Seasonal dynamics of suspended sediment plumes from the Tana and Sabaki Rivers, Kenya: Analysis of Landsat Imagery. *Remote Sensing Environment*, 16, 165-173.
- Cannon R T, Simiyu-Siambi W M N & Karanja F M (1981). The proto-Indian Ocean and a probable Palaeozoic/Mesozoic triradial rift system in East Africa. *Earth and Planetary Science Letters*, 52, 419-426.
- Caswell P V (1953). *Geology of the Mombasa-Kwale area*. Geological Survey of Kenya. Report No.24.
- Caswell P V (1956). *Geology of the Kilifi-Mazeras area*. Geological Survey of Kenya. Report No.34.
- Delft Hydraulics (1970). *Malindi Bay Pollution II*. Delft Hydraulic Laboratory, Rep. R611.
- Findlater J (1973). The low-level cross-equatorial air current of the western Indian Ocean during the northern summer. *Meteorological Magazine*, 102, 411-416.
- Halse J E P (1980). *Formosa Bay heavy mineral beach sand deposits. Initial exploration report*. Ministry of Environment and Natural Resources.
- Hesp P A & Nordstrom K F (1990). Geomorphology and evolution of active transgressive dunefields. In K F Nordstrom, N P Psuty & B Carter (eds.), *Coastal dunes, form and process*. Chichester: Wiley and Sons.
- Hori N (1970). *Raised coral reefs along the southeastern coast of Kenya, East Africa*. Tokyo Un., Department of Geography. 5, 25-47.
- Hove A R T (1980a). *Some aspects of current sedimentation, depositional environments and submarine geomorphology of Kenya's submerged continental margins*. Univ. Nairobi, IDS/OP 28, 127-144.
- Hove A R T (1980b). The 38-metre sea level. a reconstruction of the early Pleistocene Palaeogeography of the south Kenya coast. *Communique Colloque International Geologie*, 08, Symp. 23.
- Inman D L & Nordstrom C E. (1971). On the tectonic and morphologic classification of coasts. *Journal Geology*, 79, 1-21.
- Jennings J N (1964). The question of coastal dunes in the tropical humid climates. *Zeitschrift Geomorphologie*, Supplement, Bande 8, 150-154.
- Johnson D R, Nguli M M & Kimani E J (1982). Response to annually reversing monsoon winds at the southern boundary of the Somali Current. *Deep Sea Research*, 29, 104, 217-227.
- Johnson D W (1919). *Shore processes and shoreline development*. New York: Wiley & Sons.
- Kent P E. (1974). Continental margins of E. Africa- A region of vertical movements. In: Burk, C. A. & Drake, C. L. (eds.), *The geology of continental margins*. New York: Springer, pp.13-24.
- Kenya Meteorological Department (1984). *Climatological statistics for Kenya*. Nairobi.
- KMFRI (1981). The general water movement off the Kenya coast. Project KEN/74/023 work report no. 1, 2 and 3 respectively the survey activities in 1979, 1980 and 1981. Unpubl. manuscript, Kenya Marine & Fisheries Res. Inst.
- Mahoney P J B (1980). Africa Pilot Vol III- south and east coasts of Africa from Cape Agulhas to Ras Binnah, including the islands of Zanzibar and Pemba. Third edition. Hydrographer of the Navy, 25-44.
- McIlveen R (1992). *Fundamentals of weather and climate*. London: Chapman & Hall.
- Meteorological Office and Main Marine Data Bank (1990). London.

- Munyao T (1992). *Sedimentology of Shirazi-Funzi Lagoon, Coast Province, Kenya*. M.Phil. thesis, Moi University, School of Environmental Studies.
- Munyao T (1996). personal communication.
- Mwongela (1996). personal communication.
- Obura (1996). personal communication.
- Ojany F F (1984). Some aspects of the geomorphic evolution of the Kenya coast with special reference to the Kambe Limestone rocks of the Kilifi area. In: *Natural and Man-Induced Environmental Changes in Tropical Africa: Case studies in Cameroon and Kenya*. A preliminary report of the Tropical African Geomorphology and Late-Quaternary Palaeoenvironments Research Project 1982/83, Sapporo, Japan, 117-127.
- Oosterom A P (1988). *The geomorphology of southeast Kenya*. Ph.D. thesis, Wageningen Agricultural Un.
- Orme A R (1990). The instability of Holocene coastal dunes. the case of the Morro dunes, California. In K F Nordstrom, N P Psuty & B Carter (eds.), *Coastal dunes, form and process*. Chichester: Wiley and Sons, pp.315-336.
- Parker D E (1973). Tropospheric winds and the occurrence of rainfall near the Equator. *Meteorological Magazine*, 102, 26-30.
- Pye K (1983). Coastal dunes. *Progress Physical Geography*, 7, 531-57.
- Pye K (1991). Beach deflation and backshore dune formation following erosion under surge conditions: An example from Northeast England. *Acta Mechanica*, 2, 171-181.
- Rais-Assa R (1988). Stratigraphy and geodynamics of the Mombasa Basin (Kenya) in relation to the genesis of the proto-Indian Ocean. *Geological Magazine*, 125, 2, 141-147.
- Read A N (1981). *Sedimentology and lithification of Quaternary reef-rock on the coast near Mombasa, Kenya*. Ph.D. thesis, Un. of Leeds.
- Schroeder J H (1974). Sedimentology of coast and shelf environments. Notes for Regional Training Course, Malindi, Kenya. TU Berlin.
- Shepard F P (1973). *Submarine geology*. Third Edition. New York: Harper and Row.
- Short A D & Hesp P (1982). *Beach and dune dynamics of the southern coast of South Australia*. Techn. Report 84/1, Coastal Studies Unit, Univ. Sydney, 142pp.
- Sikes H L (1930). The drowned valleys on the Kenyan coast. *J. East African historical society and national museum*, 18, 1-9.
- Thompson A O (1956). *Geology of the Malindi area*. Geological Survey of Kenya. Report No.36.
- Toya H, Kadomura H, Tamura T & Hori N (1973). Geomorphological studies in the southeastern Kenya. *Geographical Report, Tokyo Metropolitan University*, 8, 51-137.
- Turyahikayo G R (1987). Wave characteristics off the east African coast. *Kenya Journal Science*, A8, 1-2, 33-58.
- Williams F (1970). The sport fishing for sailfish at Malindi, Kenya, 1958-1968, with some biological notes, *Bulletin Marine Science*, 20, 830-852.
- Williams L A J (1962). *Geology of the Hadu-Fundisa area, North of Malindi*. Geological Survey of Kenya. Report No.52.

3

COMPOSITION, STRUCTURE AND DISTRIBUTION OF COASTAL DUNE VEGETATION BETWEEN MALINDI AND MAMBRUI

W. M. MUSILA

Introduction

Sandy ocean beaches are quite often backed by sand dunes. Dunes are accumulations of sand in ridges or mounds landward of the beach berm formed by natural processes and usually parallel to the shoreline (Ranwell, 1972). Dunes originate where wind energy is sufficiently strong to transport unconsolidated sediments or weathering residues, especially sand. Dune vegetation plays a vital role in growth and stabilisation of the dunes as it is able to grow with the developing dune and to a certain extent to regenerate when the dune is damaged. Vegetation is an effective stabilising tool because it is capable of binding loose sand with their root system and grow up with more sand deposition unlike other sand barrier. This indicates that when the mantle of vegetation is broken, the dune movement is accelerated to a point where plant growth cannot keep pace with the shifting sand.

Coastal dunes receive, store and release excess beach sand. The dunes act as a buffer against storm waves and winds. The frequent temporary asymmetric sediment exchange between beach and dune is an important natural process for maintaining both morphological stability and ecological diversity. In addition to absorbing wave attack, the dunes shelter landward communities and assist in the retention of freshwater tables against saltwater intrusion. They are also important as nature reserves.

An extensive strip of sand dunes has been formed over a wide stretch of both sides of the Sabaki River. Dune building is very active due to the large supply of sand from the Sabaki River and has resulted in a unique variety of different dune types (Abuodha, 1989). However, the natural vegetation has been greatly destroyed as a result of overgrazing and also clearance of vegetation for building materials and fuelwood. This has led to sand drift to some neighbouring non-dune areas as well as loss of biodiversity.

So far, studies on the coastal dunes of Kenya have mainly been sedimentological (Abuodha, 1989). This study hence provides an ecological understanding of the sand dunes and will be a guide for the management and conservation techniques appropriate for this fragile ecosystem. The study objectives are:

- To compile a checklist of the flora on the sand dunes;
- To investigate the distribution of plant species in relation to the geomorphologic units in the sand dunes;
- To investigate the relationship between the vegetation distribution and edaphic factors among various geomorphological units.

Study Area

GEOGRAPHICAL LOCATION

The study area is in Malindi District, a 10km coastal strip between Malindi and Mambui town. It is situated between the latitudes 3°06' and 3°12'. It covers an area of 700ha with about 4km to the south of Sabaki River and 6km between Mambui town and Sabaki River (Fig 3.1)

Wind plays an important role in dune formation and the winds in this area depend on monsoonal air currents. The soils of the coastal plains where the study area lies are mainly fine sand which are well-drained, deep yellowish brown and vary from sandy to loamy texture. These soils are chemically poor because of slow chemical weathering.

Materials and Methods

SAMPLING TECHNIQUES

The geomorphology of the area was determined using direct observation and analysis of aerial photo mosaic and the findings recorded. The floristic composition in these zones was determined using the transect and quadrat methods. Six transects perpendicular to the shoreline were demarcated (Fig 3.2). Soil samples were taken from each quadrat to determine the chemical composition and texture.

PLANT IDENTIFICATION AND SOIL ANALYSIS

Plants found were identified in the field using keys and illustrations by Dale & Greenway (1961) and Agnew (1974). Plants which could not be identified in the field were taken to the Nairobi University Herbarium and National Museums of Kenya Herbarium for identification.

Sand samples were separated into different fractions using sieves of -0.1 to $+4.0$ phi mesh sizes. The sample fractions in each sieve were then weighed separately, and in order to describe them, grain size was analysed according to Fay (1989).

CHEMICAL ANALYSIS OF SOIL

The following methods were used; pH using a pH-meter, Organic Carbon using the method of Walkey and Black, total Nitrogen using the Kjeldahl method, total Carbonates by displacement method, Phosphates by Bray and Kurtis No.1 Method and CaO, MgO, K₂O and Na₂O by X-ray fluorescence spectrometry (XRY) method. Cation Exchange Capacity (CEC) was also determined by successive leaching of soils with 1M sodium acetate of pH 8.2 (Handouri, 1995).

DATA ANALYSIS

Information recorded during the field study together with a mosaic of aerial photographs were used to describe the geomorphological units. A stereoscope and parallax bar were used to measure the elevation of each geomorphological unit. The units were then identified depending on their form.

Using quantitative data of cover, frequency and density, Importance Value Indices (I.V.I.) were calculated for all the species in each geomorphological unit. Plant communities were derived from the plants which had the highest importance indexes in each geomorphological unit. The Importance Value Index data set was combined into a single data set. This was re-analysed by TWINSpan (Hill, 1979) to determine the synecological rela-

Figure 3.1 Location of the sand dunes near the mouth of the Sabaki River

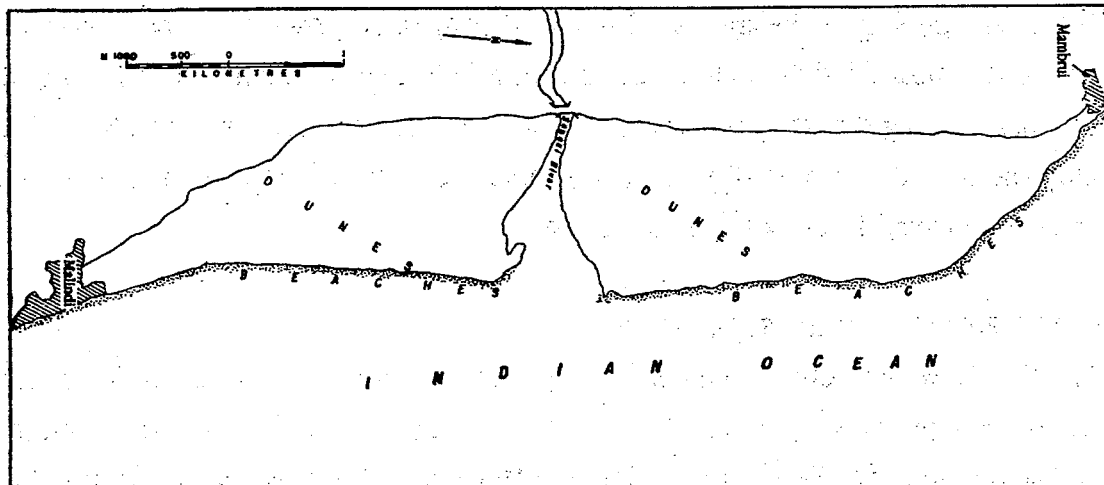

Figure 3.2 Location of sample transects near Sabaki River

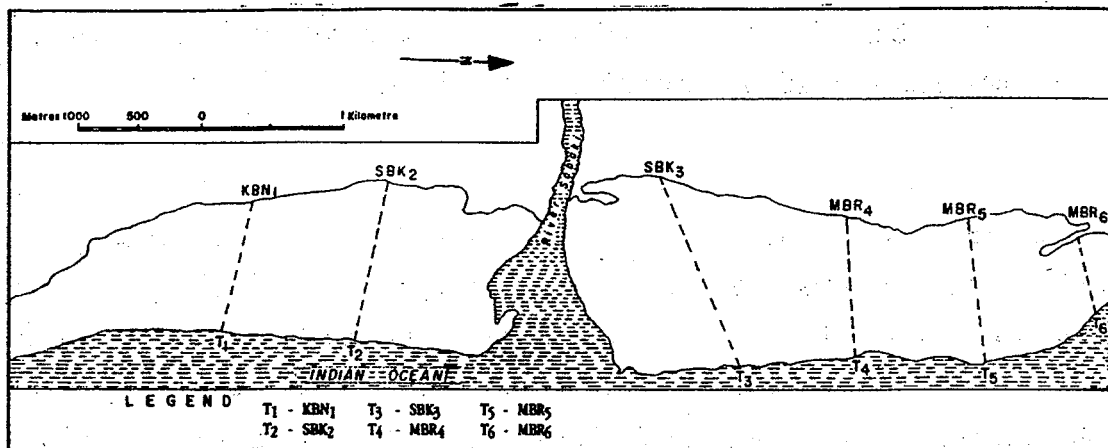
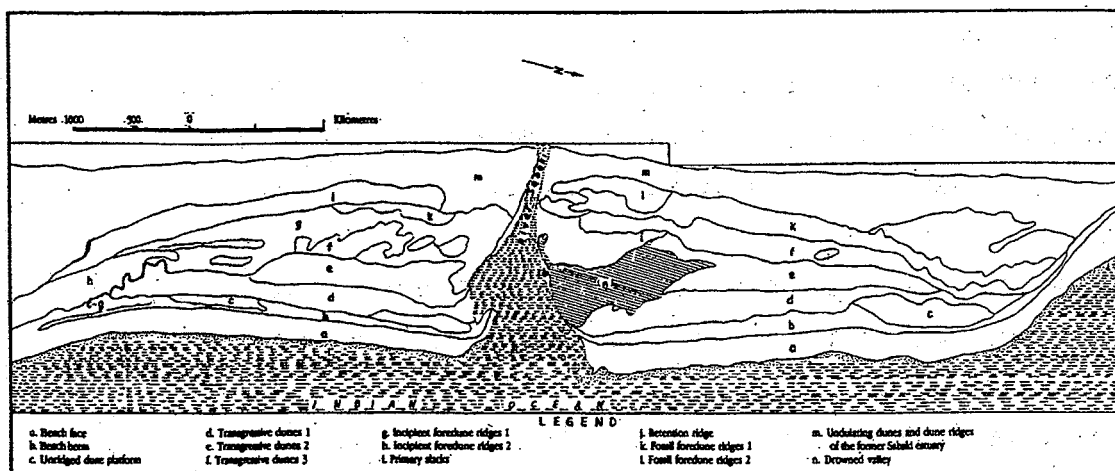

Figure 3.3 Geomorphological units of the sand dunes near Sabaki River



tionships between species and to see if the geomorphological units were distinct enough to be separated on the basis of their floristic composition.

Using SPSS, one-way ANOVA was computed to find out whether there were any significant differences in soil chemistry among various geomorphological units. Tukey test was then computed to check in which specific geomorphological units the variations occurred.

Forward stepwise regression analysis (Greig-Smith, 1983; Zar, 1984; Kent & Coker, 1992) was computed to check which soil parameters affected the distribution of the plants more than others.

Results¹ and Discussion

DUNE VEGETATION

The dune vegetation was distributed in different geomorphological units namely; the beach berm, unridged dune platform, transgressive dunes 1, 2, and 3, primary and secondary slacks, drowned valley, incipient foredune ridges and fossil foredune ridges (Fig 3.3). The vegetation of the Kenyan sand dunes was grouped in four categories: sand binders, herbs, shrubs and forest woodland. These four groups were found to occur in different geomorphologic units depending on sand dynamics.

A total number of 156 plant species was recorded belonging to 130 genera and 60 families. The largest family was that of the Gramineae with 17 different species accounting for 11 per cent of the total number of plant species. The second largest family was formed by the Papilionaceae having 16 different species accounting for 10.3 per cent of the total number of plant species. The dominant genus was *Digitaria* represented by 6 different species.

SPECIES RICHNESS & PLANT COMMUNITIES

The total number of species and the growth forms of species recorded in each geomorphological unit are shown in Table 3.1. The species richness is highest in the fossil foredune ridges (62), moderate in the drowned valley (40) and lowest in the transgressive dune 2 (2). This indicates that the species diversity is higher in the fossil foredune ridges than in any other geomorphological unit. The fossil foredune ridges have also the highest number of tree species, while the other geomorphological zones were occupied mainly by grasses and herbs. A detailed description of the different geomorphological zones is beyond the scope of this paper. However, the different plant communities characterising these zones are described below.

1. Detailed results are given in Musila (1996).

Table 3.1 Species richness and different growth forms by geomorphological units

	Species (no.)	Growth form				
		Grass	Herbs	Shrubs	Trees	Climbers
B	5	1	3	1		
C	4	1	2	1		
D	3	1	2			
E	2	1	1			
F	23	6	9	4	1	3
G	26	6	6	9	1	4
I	30	8	15	5	1	1
N	40	8	18	9	2	3
K	62	4	20	17	14	7

Key

B- Beach berm	E- Transgressive dune 2	I-Primary and Secondary slacks
C-Unridged dune platform	F-Transgressive dune 3	N- Drowned valley
D-Transgressive dune 1	G-Incipient foredune ridges	K- Fossil foredune ridges

BEACH BERM

Two plant communities were identified in this zone namely; *Ipomoea pes caprae* (L.) R.Br. and *Halopyrum mucronatum* (L.) Stapf. The *I. pes caprae* community was found to be more dominant on the beach berm south of Sabaki River. *I. pes caprae* is stoloniferous in nature with long creeping runners which develop adventitious roots at the nodes. This species is characterised as a sand binder due to this growth pattern. It had the highest I.V.I.(68.8). This indicates that it contributes most to the vegetation of the entire zone. Some accompanying shrub, herb and sedge species were also present in this community.

The *H.mucronatum* community is a grassland community occurring north of the Sabaki River. With cover ranging from 30-50 per cent it is the only plant species in this community. This rhizomatous grass grows up to 50cm or more in height and rapidly pushes through the sand using its hard and sharp apices of the rhizomes and adventitious roots.

UNRIDGED DUNE PLATFORM (EMBRYO AND SHADOW DUNES)

It has a species richness of four, with two plant species being herbs, one a grass and the other a shrub. Two plant communities were identified namely: *H.mucronatum* and *Haembaedia gregoyii* C.B.Clarke. The characteristics of the former were already described above. It occurs north of the Sabaki River and has the highest I.V.I. (146.6) in this unit. The *H.gregoyii* community is common to south of the Sabaki River. It is a fleshy creeping herb and forms a carpet-like mat on the embryo dunes and is a sand binder.

TRANSGRESSIVE DUNES

These are active and mobile dunes which form long, wave-like ridges separated from each other by flat bottomed troughs or interdune flats. The mobility of these dunes affords little opportunity for the development of plant cover. In total, this zone has a species richness of 24 (Table 3.1). Transgressive dunes 1 and 2 have very scanty vegetation which is either grass or herbal in nature. Transgressive dune 3 has a species richness of 23 with most of the plant species being herbs. It is in this zone that trees and climbers first appear (Table 3.1) indicating that it may be more stable than the other transgressive dune zones. Three plant communities were identified, namely; *H. mucronatum*, *I. pes caprae* and *Cordia somalensis* Bate.

The *H. mucronatum* is a high-grass community which occurs north of the Sabaki River in transgressive dunes 1 and 2 with the highest I.V.I. in both transgressive 1 and 2 (112.8 & 166.9). It grows vigorously especially when covered by sand, which enables it to survive in this mobile region. As this grass grows, it forms sand bars. A few strands of *I. pes caprae* are also present.

The *I. pes caprae* is a herbland community which occurs south of the Sabaki River in transgressive dune 1. It is the dominant species and *H. gregoyii* is the other accompanying plant (see earlier description). The plants in this community are scantily distributed with cover ranging from 1 to 25 per cent. They occur mostly on the deflation plains between the transverse dunes.

The *C. somalensis* is the first woody shrub community to become established on mobile dunes. Structurally, this community forms a thicket. It occurs on transgressive dune 3 zone, further from the sea, usually after the more active mobile dunes. Sandhills occur in this zone thickly vegetated by woody shrubs including *Azima tetracantha* Lam., *Phyllanthus reticulatus* Poir. and *Pluchea discoridis* (L.) Dc.

The transgressive zone 3 has a higher species richness with 23 as compared to the other geomorphological units covered so far. The cover of this community ranges from 1 to 75 per cent with *C. somalensis* having the highest cover. *P. discoridis* is especially common south of Sabaki River. Stunted trees of *Dobera glabra* (Forsk.) Poif. are also common to the north of Sabaki River. Herbs and grasses grow beneath the thickets of shrubs. Climbers such as *Cissus rotundifolia* (Forsk.) Vahl are also present in this community on edges and crests of the thickets intermingling with the foliage of the canopy from ground level to maximum height. Many species in this community exhibit xerophytic modifications which help to retard water loss and conserve water.

INCIPIENT FOREDUNE RIDGES

This zone occurs far from the sea and only on the southern part of the Sabaki River as low linear ridges which run sub-parallel to the coast. Sand is still moveable, but on the whole the surface is fixed and humus starts to accumulate. It has a richness of 26 (Table. 3.1). Two plant communities were identified in this zone; *Tephrosia purpurea* (L.) Pers. and *C.somalensis*. The first is a herbaceous community which covers the ground surface forming a mat. *T.purpurea* has the highest I.V.I. (96.0) with cover of 1 to 82 per cent and contributes most to this geomorphological unit. Other herbs and grasses were also present in this community.

The *C.somalensis* is a continuation of the community occurring in transgressive 3. It is a shrub land community which forms thickets on the sandhills with cover ranging from 1 to 50 per cent. Other accompanying shrubs were found present which frequently form a single dense layer ranging from about 1 to 5m tall. Often this layer is infested by a parasitic plant species, *Cassytha filiformis* L., which forms a mat on the canopy of the shrubs and this helps to counteract wind speed. Underneath these shrubs are a few herbs and grasses scantily distributed.

SLACKS

Slacks occur in sheltered low-lying depressions, hence they are damp stable sand surfaces which provide an ideal habitat for the rapid development of plant communities. This zone has a species richness of 30 with most of the plant species being herbs and grasses (Table 3.1). Succulent herbs, grasses and some beach berm species make up the characteristic flora of this zone. Two plant communities were identified, namely *T.purpurea* – *H. mucronatum* and *Phyla nodiflora* (L.) Greene – *Fimbristylis cymosa* (Lam.) R.Br. Overall, *T.purpurea* has the highest I.V.I. (49.5).

The *T.purpurea* – *H.mucronatum* community occurs on the dry slacks and species were found to be xeromorphic in nature and dependent on either dew or rain for their source of water. *T.purpurea* is especially common in the dry slacks south of Sabaki River and it is accompanied by some grasses and a few stands of shrubs and trees. *H.mucronatum* occurs in the dry slacks north of Sabaki River. Due to its rhizomatous nature it spreads fast, forming dense tufts on the dry slacks.

P.nodiflora – *F.cymosa* communities occur on the wet slacks and comprise predominantly hydrophytic sedges such as the *Cyperus rotundus* L.. Other sedge species are also common indicating that the water table must be near the surface. Other accompanying grasses and herbs were also present in this community.

DROWNED VALLEY

The water table was found to remain near the surface for most of the time in this zone, hence it is densely colonised by plants. This geomorphologic unit has a species richness of 40 with most of the plants being herbs (Table 3.1). The plant cover of this unit ranges from less than 1 to 90 per cent. *F.cymosa* has the highest I.V.I. (30.48). Two plant communities were identified in this zone namely; *F.cymosa* – *Sporobulus virginicus* (L.) Kunth and *T.purpurea* – *P.nodiflora* communities.

In the former community, low tussocks (15-30cm) of *F.cymosa* were present intermingled with species of *S.virginicus* which form a dense mat of vegetation and are heavily grazed by cattle. Other herbs were also common in this community.

T.purpurea-*S.virginicus* community has *T.purpurea* as the dominant species intermingled with densely distributed species of *S.virginicus*. Other accompanying herbs, shrubs and trees were also present.

FOSSIL FOREDUNE

These are two old foredune ridges with the seaward ridge being discontinuous and modified by recent aeolian sand to remnant knobs and blow-outs. The other ridge is unmodified, more stabilised and support a rich variety of plant species. This geomorphological unit has the highest richness with 62 species (Table 3.1). In some sections of this zone, the vegetation has been cleared to pave way for settlement. Where the sand dunes have been little disturbed, the vegetation is rich in species with *C.somalensis* shrub being the most dominant. The soil in this zone is well developed and comparatively rich in humus. Frequently, three layers were distinguished; a tree layer, shrub layer and herb layer. Climbers are also abundant in this zone. Two plant communities were identified in this zone, namely; *C.somalensis* – *P.disoridis* and *Justicia flava* Vahl – *Asystasia gangetica* (L.) T.Anders.

In the first, *C.somalensis* is more dominant and forms the shrub layer with cover ranging from less than 1 to 80 per cent. It includes medium to tall shrubs interspersed by trees which occur in the sheltered zone of the remnant knobs. Climbers were also present and form a dense mat on the canopy of this community especially the *C.filiformis* species. The *J.flava* – *A.gangetica* community forms the herb layer dominated by the above two plant species which occur beneath the *C.somalensis* – *P.disoridis* community. The cover of this community ranges from about less than 1 to 35 per cent, with the above two plants contributing the most. Other accompanying herbs and grasses were also present.

CLASSIFICATION OF GEOMORPHOLOGICAL UNITS

Multivariate analysis of the I.V.I. for all species in the units resulted in the following ecological classification of geomorphological units. The first division separated the beach berm, unridged platform and transgressive dunes 1 and 2 from the other geomorphological units. These four geomorphological units had the lowest species richness dominated by herbs and grasses and occur near the sea. *H. mucronatum* community is common.

The second division on the five remaining geomorphological units separated the drowned valley and slacks from the transgressive dune 3, incipient foredune ridge and fossil foredune ridges. The drowned valley and slacks are damp areas with distinct vegetation dominated by succulent herbs. *P. nodiflora*, *F. cymosa* and *T. purpurea* are common in the two geomorphological units. However, the transgressive dune 3, incipient foredune ridge and fossil foredune ridges are found in more stabilised areas. Shrubs are more common with *C. somalensis* being dominant.

Thus, most of the groups defined by TWINSpan consist of geomorphological units sharing common plant species and having almost similar characteristics. It appears that similar geomorphological units have distinct vegetation types.

SOIL PROPERTIES

Generally, coastal sands are nutrient-poor (Rieley & Page, 1990). The sand on this dune system was observed to have low levels of organic matter, slightly acidic to alkaline in reaction (pH) and fine to medium grained.

The highest values of pH (8.42), %Magnesium (Mg; 3.42), Phosphorus (P; 0.98) and mean particle size (0.308) was recorded in drowned valley (Table 3.2).

The sand pH throughout the dune area ranges from 5.87-8.42. The highest %Carbon (0.109%) an indication of organic matter composition, was recorded in the fossil foredunes and the lowest in the transgressive dune 2 (0.007%). This is expected since the fossil foredunes are more vegetated and hence accumulate more organic matter while in the transgressive dunes which are very mobile, there is little or no vegetation.

The concentration of %Sodium was interpreted to indicate the amount of salt (NaCl) in the sand. The highest %Na₂O (3.22%) was recorded in the unridged dune platform about 60-100m from the sea. This indicates that the influx of salt by sea spray is high. Salt crusts were observed in this geomorphological units indicating that wind deposits salt on the surface of the sand. The lowest value of %Na₂O (1.42%) was recorded in the drowned valley, this is explained by the fact that the water table is near the surface hence, most salt deposited on the surface is leached to the water table. Considering the amount of salt spray

carried over the dunes, which is actually visible, the amount of %Na₂O is expected to be high. But this was not found to be the case indicating that leaching must be very rapid.

Potassium concentration in the sand was much lower than those of Sodium and showed variability. %K₂O was generally higher in sand taken from the drowned valley and lowest on the beach berm near the sea.

Available Nitrogen(N) was higher on the fossil foredunes than in any other geomorphological unit reflecting the higher organic content of the sand. On the other hand, a relatively high concentration of Nitrogen and %Carbon was recorded on the beach berm. This is attributed to the initial organic matter supplied to the shore in tidal litter, which forms a rich nutrient medium for the pioneer plants.

Phosphorus concentration was generally low ranging from 0.00-1.26 (ppm). The highest phosphorus concentration was recorded on the transgressive dune 2 and the slacks, while the lowest (0.00) was recorded in seven geomorphological units.

CEC was relatively low and this is explained by the low levels of organic matter and minimal clay and this limits the supply of cations to plants.

The highest %Calcium Carbonate (CaCO₃) was recorded on the beach berm just next to the sea, while the lowest on the fossil foredunes. Shell fragments were observed on the beach berm and this indicates that the high %CaCO₃ concentration is due to the shell fragments blown by the wind to this zone. However, high %CaCO₃ concentration was not maintained as decalcification (leaching) effects are rapid. The lowest concentration of Calcium and Magnesium were recorded in the slacks.

The mean particle size of sand from the dune system was either medium or fine grained. The highest mean particle size was recorded on the unridged dune platform just next to the beach berm.

RELATIONSHIP BETWEEN VEGETATION DISTRIBUTION AND SOIL PARAMETERS

Significant differences in the soil parameters pH, organic carbon, %Na, %Ca, %K, %Mg, %CaCO₃, %N, P(ppm), CEC and mean particle size were detected both between the geomorphological units and in the plots (quadrats) within the geomorphological units ($p=.001$). Tukey test revealed the geomorphological units which had similar soil parameters and those where differences were detected ($p=.001$).

Generally, significant variations in most of the soil parameters were detected in incipient foredune ridges and transgressive dunes. These are intermediate dunes where stabilisation of dunes begins. These dunes occur about 700 m from the sea so there may be lack of incoming nutrients through salt spray and wind. This may increase competition for the nutrients pool by the plant species which become established on this dune.

Table 3.2 Ranges of chemical measures of the dune soils in different geomorphological units

	B	C	D	E	F	I	N	G	K
pH (H ₂ O)	5.87 - 7.72	6.07 - 6.42	5.97 - 6.66	5.97 - 6.71	6.34 - 7.20	6.32 - 7.42	6.14 - 8.42	6.41 - 6.80	6.21 - 6.79
pH (KCl)	6.51 - 7.00	5.95 - 7.13	6.48 - 7.14	5.95 - 7.60	6.08 - 6.88	6.38 - 8.06	5.83 - 8.18	5.83 - 6.36	5.94 - 7.24
% Carbon	.023 - .073	.023 - 0.051	.015 - .008	.007 - .087	.044 - .058	.015 - .073	.051 - .102	.029 - .051	.044 - .109
% Na ₂ O	1.91 - 2.75	2.03 - 3.22	1.83 - 2.35	1.62 - 2.42	2.08 - 2.79	1.67 - 3.00	1.42 - 2.73	2.21 - 2.65	1.73 - 2.90
% K ₂ O	1.22 - 2.09	1.62 - 2.30	1.3 - 1.83	1.24 - 1.94	1.54 - 1.81	1.52 - 2.47	1.52 - 2.18	1.62 - 1.81	1.38 - 2.08
% CaO	2.53 - 4.13	2.35 - 2.92	2.4 - 4.01	2.86 - 4.14	2.85 - 3.42	1.16 - 3.45	1.75 - 2.97	2.96 - 3.26	2.83 - 3.68
% MgO	.82 - 2.65	.82 - 1.20	1.4 - 1.95	1.09 - 2.19	1.10 - 1.62	.48 - 2.76	1.03 - 3.42	1.18 - 1.41	.91 - 1.88
P (ppm)	.00 - .42	.00 - 0.14	.14 - .56	.00 - 1.26	.00 - 0.42	.00 - 1.26	.42 - 0.98	.00 - .84	.00 - .28
% N	.002 - .12	.004 - .012	.002 - .18	.002 - .016	.004 - .016	.002 - .018	.004 - .012	.004 - .006	.004 - .28
CEC	.40 - .48	.40 - .48	.40 - .64	.16 - .72	.40 - .48	.40 - .56	.40 - .64	.40 - .48	.40 - .48
% CaCO ₃	.10 - .37	.10 - .17	.05 - .22	.05 - .14	.05 - .27	.05 - .19	.07 - .16	.05 - .07	.001 - .009
Mean Particle size	.244 - .297	.199 - .308	.176 - .288	.168 - .290	.183 - .280	.204 - .222	.221 - .308	.195 - .252	.153 - .238

Key: See Table 3.1

Significant variations were also detected in the drowned valley and slacks. This could be attributed to the effects of proximity to ground water which leads the rate of leaching of most soil nutrients to be high.

Fossil foredunes ridges which are more stabilised and have older soils also showed significant variations in pH, %Carbon, %CaO, %MgO and %CaCO₃. These soils have more organic matter and the significant variability could be due to the recycling of nutrients from organic matter to plants.

Results of stepwise regression procedures revealed that mean particle size of the sand, CEC and %Na₂O are the most significant ($p < .05$) independent variables determining vegetation composition and distribution.

The coefficient of determination (R^2) for each variable and probabilities (P) and F-values are given respectively as follows: mean particle size (0.026, 0.005 and 7.9), CEC (0.044, 0.0013 and 6.83) and %Na (0.058, 0.005 and 6.13). No significant relationships were found (.05 level) between vegetation composition and distribution and the soil parameters pH, %Carbon, %CaO, %MgO, P(ppm), %N and %CaCO₃.

The above results suggest that the mean particle size of the sand plays a major role in determining the species distribution. The variation in the particle size occurs in different geomorphological units. High mean particle size was recorded on the unridged dune platform indicating that the sand is medium grained. This geomorphological unit is mobile and exposed to wind attack and hence fine particles are carried inland leaving a surface layer of medium sand. Due to the medium texture of the sand, other soil processes are also affected. The rate of leaching increases due to the free-draining of the soil. Sometimes the medium grained layer of sand becomes buried by a fresh deposit of finer particles leading to horizontal layering of coarse and fine sand.

The vegetation cover in the unridged dune platform is scanty and this could be attributed to the texture of the sand which affects other soil processes. Due to the continuous disturbance of the sand, most of the plants spread widely by means of rapidly extending horizontal growth, for example, the *H. mucronatum* grass which is rhizomatous in nature.

The mean particle size of the transgressive dunes 1 and 2 sand remains almost constant and is medium grained in nature. This is also an active, mobile zone where the fine grained sand is blown by the wind leaving only the medium grained sand. Very few plants were recorded on this geomorphological units.

Sand on the transgressive dune 3, incipient foredune ridges and slacks is fine grained in nature. These three geomorphological units are more stable and have a high species richness indicating that most plants do well in fine grained sand and stable environments.

From the stepwise analysis, %Sodium was singled out as an important factor influencing the distribution of the plants. The highest mean %Na₂O was recorded in the unridged dune platform. This is because of the effect of salt spray. Low mean %Na₂O values were recorded on the transgressive dunes 1 and 2. This could probably be due to the mobile nature of these dunes which makes the rate of leaching very rapid.

The mean %Na₂O rises in transgressive dune 3 and incipient foredune ridges 1. This can be explained by the high altitude of these geomorphological units. These units occur as ridges which are rather high, so most of the wind blown salt is deposited here as the dune ridge acts as an obstacle to the wind. The geomorphological units are relatively vegetated, indicating that they can withstand the high salt content.

The mean %Na was quite low in the drowned valley and can be attributed to the proximity of the water table and also the seasonal flooding of this area by fresh river water. This dilutes the salt content on the sand. Thus, most of the plants found on this zone thrive well in non-saline soils.

Cation Exchange Capacity(CEC) was also singled out as one factor that could influence the distribution of plants. However, CEC values were found to be relatively low and uniform and did not seem to have consistent variations which would serve to explain the zonal distribution of the vegetation.

Conclusions and Recommendations

Two major subdivisions of plant communities were singled out according to the stability of the sand. Communities of stable sand occur as established vegetation and communities of unstable sand occur in the first four geomorphological units. Between these two extremes is an overlap of communities on intermediate or mixed sand or semi-stabilised dunes. The following conclusions were drawn:

1. Sand dynamics play an important role in determining the distribution of the plant communities on the dunes. Thus activities that cause instability of the sand such as clearance of vegetation for fuelwood and grazing will greatly affect the vegetation distribution.
2. To maintain the dune ecosystem, the vegetation which reduces the amount of sand transport should be carefully managed and closely monitored to detect any changes that may occur.
3. There were distinct changes in plant communities observed from the coastal to the landward side of the dune system. This suggests that a wide range of macro- and micro-environments exists within the dunes zones causing the variability in plant communities.

4. Chemical analyses of the dune soils indicate that the soils are nutrient-poor. The distribution of nutrients within the dunes varies from place to place and it is likely that the local patterns observed in the dune vegetation are, at least in part, due to differences in nutrient levels.

5. The soil-vegetation relationships revealed that mean particle size, Sodium concentration and CEC were the major soil factors determining vegetation variation. However, only mean particle size had consistent variations which can serve to explain the zonal distribution of the vegetation.

6. The present study provides data on vegetation of the sand dunes which is one factor important for sand dune formation. The study provides insight in the vegetation dynamics and the dune environment and this information is important for proper management of the dunes.

7. More research is required in the following areas:

- Autecological studies on possible dune-fixing plan
- Establish why *H. mucronatum* only grows to the north of the Sabaki River and *I. pes caprae* only to the south;
- Study the interaction between past human use of the dunes and other physical and biological processes that have influenced dune topography. With such a study, areas of high geomorphological interest will be identified and also factors that have produced the present landscape;
- Study the hydrology of the dunes to furnish important information necessary for assessment of the impact of the groundwater abstraction from the slacks.

The coastal sand dunes fall in a sort of 'no man's land' between terrestrial and marine ecosystems and frequently they are ignored by conservation and management authorities. The small but dynamic area give the mistaken impression that it is not important, hence that there is no need for protection. Yet it protects the landward communities from the seawaves.

The dune system is an enormously valuable and fragile ecosystem which should not be altered in any way. This system should be set aside for nature conservation and prosperity of the area. The vegetation destruction should be halted to maintain the stability of the dunes. The shifting dunes should be maintained by establishing dune fixing plants and introducing them on the affected parts of the dune system.

Abstract

The coastal sand dunes are one of the coastal ecosystems in Malindi District which borders the Indian Ocean. The dunes between Malindi and Mamburi town extend to over about 10km and cover an area of about 700ha.

This study describes the composition, structure and distribution of the dune vegetation. Possible edaphic factors which may affect the distribution of the vegetation were also investigated. The area was studied by air-photo interpretation, field sampling and laboratory analysis. Six transects were demarcated perpendicular to the sea. With the help of these techniques geomorphological units were distinguished, namely; the beach berm, unridged dune platform, transgressive dunes 1,2 and 3, incipient foredune ridges, primary and secondary slacks, drowned valley and fossil foredune ridges.

A total of 156 plant species were identified representing sixty families with Gramineae (17 species) and Papilionaceae (16 species) being the most represented. Fifteen plant communities were described in the different geomorphological units. A distinct zonal distribution of the plant communities was found.

A TWINSpan analysis grouped geomorphological units of similar localities, mainly on the basis of their species composition. The *Halopyrum mucronatum* and *Ipomoea pes caprae* communities were common in the more unstable beach berm, unridged dune platform, transgressive dune 1 and 2. While the *Cordia somalensis* community was found in the more stable geomorphological units including transgressive dune 3, incipient foredune ridges and fossil foredune ridges.

Significant variations in the soil parameters in different geomorphological units were detected ($p=.001$). Sand dynamics and mean particle size of the sand were the most important factors influencing the vegetation composition, structure and distribution. Other important research studies are proposed to help in the proper management of these dunes. It is recommended that the dunes should be preserved for nature conservation and prosperity of the area.

Acknowledgements

I thank Prof.P.D.Jungerius, Prof.M.P.Tole, Dr.Okemwa, Mr.Monor, Mr.S.Mathenge and staff of the School of Environmental Studies (Moi University) for their assistance at various times in the field. Special thanks go to Dr.Okeyo (Moi University) for his immense support and extensive suggestions in preparation of this paper. Financial support was provided by the Dutch government and African Academy of Sciences to whom I am very grateful.

References

- Abuodha J O Z (1989). *Morphodynamics and sedimentology of the Malindi-Fundisa coastal area associated with heavy mineral deposition*. M.Sc. Thesis, University of Nairobi.
- Agnew A D Q (1974). *Upland Kenya wild flowers*. London: Oxford University Press.
- Dale I R & Greenway P J (1961). *Kenya trees and shrubs*. London/Nairobi: Matchards/Buchenan's Kenya Estates.
- Fay (1989). Grain size analysis computer package, University of Dar-es-Salaam, version 10-07-1989.
- Greig-Smith P (1983). *Quantitative plant ecology*. 3rd edition. New York: Blackwell.
- Handouri (1995). *Analytical methods: Methods for soil analysis: Service laboratory for soil, plant and water analysis*. Minia University (Egypt), Soil Science Department.
- Hill M O (1979). *TWINSpan: A Fortran program for arranging multivariate data in an ordered two-way table by classification of individuals and attributes*. Ithaca, Cornell University, Ecology and Systematics.
- Kent M & Coker P (1992). *Vegetation description and analysis: a practical approach*. London: Belhaven.

- Musila W (1996). *Floristic composition, structure and distribution patterns of coastal dune vegetation: A case study of coastal dunes between Malindi and Mamburi*. M.Phil. thesis, Moi University, School of Environmental Studies.
- Ranwell D S (1972). *Ecology of salt marshes and sand dunes*. London: Chapman and Hall.
- Rieley J & Page S (1990). *Ecology of plant communities: A phytosociological account of the British vegetation*. New York: John Wiley.
- Zar J H (1984). *Biostatistical analysis*. New York: Prentice -Hall.

4

ENVIRONMENTAL EFFECTS OF COASTAL SEDIMENTATION A CASE STUDY OF SHIRAZI-FUNZI LAGOON

T.M. MUNYAO

Introduction

STUDY AREA AND PREVIOUS WORK

Shirazi-Funzi Lagoon is situated about 70 km Southwest of Mombasa. It occurs within longitudes 39°22'E and 39°27'E, and latitudes 4°30'S and 4°35'S and covers about 57 km². The study area lies in the coastal plain, which is below the 30m contour, and is underlain by coral limestone of the Pleistocene age (Caswell, 1953), and lagoonal deposits from both land and sea. Both the hinterlands at Shirazi and the Funzi Island are underlain by the MtoMkuu formation of upper and lower Cretaceous, of the Post Karoo systems (Rais-Assa, 1987). This formation is overlain by Pleistocene sands that cover the Funzi Island and a narrow strip of the coastline immediately north of Funzi Island.

The Ramisi River and a few other seasonal streams discharge into the lagoon. The cli-

Table 4.1 Stratigraphy of the Mombasa Basin

SYSTEM	GEODYNAMIC FRAMEWORK	AGE	FORMATION	LITHOSTRATIGRAPHY *	PALAEO-ENVIRONMENT			
P O S T - K A R O O	P O S T - R I F T	CRETACEOUS		*	Shales, sandstones and limestones silty clays	Transgressive marine		
		J U R A S S I C	upper				MTO-MKUU	upper
			middle			KAM-BE	upper lower	
		lower	MAZE-RAS			upper lower	Grits sandstones Coarse sandstones (silicified woods)	Deltaic to eolian
			TRIASSIC			MATOLAN		
		K A R O O	P R E - R I F T			PERMIAN	upper	MARIA-KANI
lower	MAJI YA CHUMVI			middle	Argilaceous sandstones Sandy shales (fishbed)		Lacustrine	
upper	TARU			middle				Sandstones and carboniferous shales Arkose and conglomerates Arkosic sandstones
lower	UPPER CARBONIFEROUS			Tillite	Peri-Glacial			
				basement	basement			

* Unconformity with other categorizations

mate of the area is related to the semi-annual passage of the Inter Tropical Convergence Zone; the north-east and south-east monsoon seasons are experienced from November to March, and April to October respectively. Short and long rains are experienced from November to December, and from March to June respectively. The average annual temperatures of the area exceed 28°C (NES, 1985). Thick mangrove cover occurs in the lagoon, while savannah-type grass and shrubs occur in both the mainland and Funzi Island. Coconut and cashewnut trees have been planted in the mainland by inhabitants, while a few coconuts have been planted on Funzi Island.

Caswell (1953); Cannon *et al.* (1981); and Rais-Assa (1987) show that the study area comprises sedimentary strata of the Karoo system, with the oldest stratum being upper-carboniferous (Table 4.1).

This study was conducted to determine:

- factors that affect the sedimentology of Shirazi-Funzi lagoon;
- sediment types and source environments;
- economic importance of the lagoon;
- environmental problems that relate to the sedimentology in the lagoon;
- possible management policies for Kenya's lagoons.

Method ¹

GEOMORPHOLOGY

Physical features were recorded, while profiling was done with the use of a theodolite, mounted on a tripod stand. Profiling was done during tidal ebbs, and along some transects perpendicular to shoreline and others cutting through sand bars. Profiling and visual methods were applied to determine the possible effects of sea level rise on the area. Shorelines where heights of cliffs or beaches above high water mark were minimal were classified as most prone to effects of sea level rise. Erosive and non-erosive environments were recorded.

HYDRODYNAMICS

Wave Energy

Wave heights were measured at the tidal inlet south of Funzi Island using a pole along two transects, each from the tidal inlet toward the two main channels respectively. The density

1. Further details on method, i.e. sampling points and transects, are given in Munyao (1992).

of the sea water was determined by measuring the run of known volumes of water. The following formula was applied in the determination of wave energy (E):

$$E = 0.5\rho ga^2 \quad (\text{Dyer, 1986}) \quad (2)$$

Ocean currents

Surface current directions and velocities were measured by use of buoys at tidal inlet and along Mamuja channel.

SUSPENDED SEDIMENT YIELD BY RAMISI RIVER

Total suspended matter in Ramisi River was determined by filtration. Sediment fluxes were then calculated as:

$$Q_s = QS \text{ g/s} \quad (3)$$

and

$$Q = AV \text{ m}^3/\text{s} \quad (4)$$

Buoys were used to estimate the velocity of the river at the Gauge station.

From Q_s , annual discharge (Q_d) of total suspended matter can be given by the formula

$$Q_d = 31.5576 Q_s \text{ tonnes per year.}$$

TOTAL ORGANIC CARBON IN SUSPENDED MATTER

At the Kiwambale sampling station, suspended matter was filtered out and Particulate Organic Matter (POC) determined spectrophotometrically according to the procedure described by Johnson (Parsons *et al.*, 1984).

SEDIMENT SAMPLING AND ANALYSIS

Surface sediment samples were analysed for grain size distribution by sieve analysis. Using cumulative curves generated after sieving, the mode, mean grain size, median grain size, standard deviation, sorting, skewness and kurtosis were determined and described by applying the methods adopted by Hakanson & Janson (1983). Microscope, X-ray diffraction, and magnetic separation analysis were applied to indicate mineral content of the samples. Carbonate mineral content was determined by digesting the carbonate minerals in a 3 to 5g sample with diluted hydrochloric acid (30% HCl) until no more gas was produced. Percentage loss in dry weight was taken as percentage level of carbonate minerals. Total or-

2. E = wave energy, ρ = density of seawater, a = wave amplitude, g = acceleration due to gravity (9.8 ms⁻²).

3. Q_s = total suspended yield per second; Q = water discharge; S = average amount of total suspended matter per unit volume of river water.

4. A = cross-sectional area of the river at gauge station, V = average velocity of the river at the gauge station.

ganic carbon was determined by adding 10% Hydrogen Peroxide to 3-4g of sample and allowing the reaction to continue until no more gas was produced. The percentage loss in dry weight was taken as the total organic carbon content in the sample.

HUMAN ACTIVITIES

Questionnaires, which dealt mainly with mangrove and fisheries resources, were randomly distributed among 30 local inhabitants at mangrove and fish landing sites, who harvest both mangrove and fisheries resources. All inhabitants who received questionnaires responded. Using the response data, average daily harvest and prices for mangroves and fisheries resources were determined. Correlation analysis was done to determine inter-relationships between fish harvesting, distance from respondents' homes to the lagoon, family size, and mangrove harvesting.

Results⁵

GEOMORPHOLOGY

General Morphology

Three morphologic sections were observed in the study area. The sub-aerial morphology forms the mainland and Funzi Island. The mainland shoreline is indented and relatively straight in some parts. In the southern part many cliffs have formed due to exposure to stronger waves and currents from the sea. Fewer cliffs and many beaches occur from the central part of the mainland shoreline to the extreme north. High cliffs with cavernous structures are found in the southern and seaward facing sides of Funzi island shoreline. Beach erosion is evident in the southern part of the islands shoreline in the lagoon-facing side. In the northern part, beach and non-cliff environment is observed.

The sub-tidal morphology covers about 47 per cent of the lagoon, and comprises the mangrove islands. From the edges of the mangrove islands towards their centres, there is decrease in mangrove cover and change in species composition, from *Rhizophora mucronata* at the shoreline (channel bank) to *Avecinia marina* at near the centre and other species occurring in between. Gradual increase in relief is also observed in the same direction.

The sub-aqueous morphology is represented by the channels, the area between channel mouths and tidal inlet, the coral reefs, and the bottom morphology seaward from the study area. Three main channels occur in the lagoon; the Uvinje channel which is about 8.5 km

5. Detailed results are given in Munyao (1992).

long with width varying from 0.7 km at its confluence with Vikuarani channel, to about 5m at its termination in the northern part of lagoon; the Vikuarani channel which is about 1.3 km long and has a width varying from 0.36 km to 0.21 km; and the Mamuja channel with its mouth at southern part of the lagoon. The Mamuja channel is about 5.1 km long with a width varying from 0.8 km at its mouth to about 6m at its landward termination, where it merges with the Ramisi River. Other channels merge with seasonal streams, or end at points where run-off water enters the lagoon during rainy seasons. Channels open into the southern part of the lagoon, giving way to area between channel mouths and tidal inlet. Depths along channels are not uniform due to sedimentation, but vary from 0.5m to 5m during low tide, where sedimentation processes are at lower rates.

The area between channel mouths and the tidal inlet south of Funzi covers about 11km². It is characterised by patches of sediments, sandbars, and outcrops of coral limestone rock. Most sandbars occur near mouths of channels. At the mouth of Mamuja channel, sandbars range in height from 0.25m to 1.2m, and in length from 80m to 710m. Small ponds are observed in areas between sand bars during tidal ebb. In these areas, animal burrows and some sea grass are observed. In the erosive parts, outcrops of coral limestone are observed. Shoreline orientation in the area appear to cause the formation of these sandbars through complex reflection and refraction processes of ocean waves and currents.

The coral reef is poorly defined. Three fragments of the coral reef occur at the tidal inlet. From these fragments seaward, the slope steepens and a trough, which is an extension of Pemba channel, is encountered. This trough has a maximum width of about 36km and is about 380m deep. It ends north of the study area between Msambweni and Gazi.

Erosive environments

Erosion is observed mainly in the southern part where waves and currents entering from the sea are strongest. Cliff erosion is observed where coral limestone occurs along the

Table 4.2 *Table of possible effective flooding in Shirazi-Funzi area in the event of sea level rise*

	Slope of land at shoreline area	Area flooded due to 1m. rise in sea level (m)
A (south of Funzi island).	0.047	21.28
B (middle of Funzi island shoreline)	0.03	33.30
C (north of Funzi island)	0.18	5.56
D (Bodo)	0.0045	222.22
E (Kiwambale)	0.0025	400.00

* Distance inland from shoreline (m)

shoreline. At Funzi Island, houses were found to be at risk that were only 1m from the high water level, due to continuous shoreline erosion. In parts where mangroves have been harvested, especially in the seaward side of mangrove islands in the southern parts of the study area, and in the area between Mamuja channel mouth and tidal inlet, erosion was observed.

Effects of sea level rise

In the study area, most beaches grade into mangrove islands. In the event of sea level rise, Mangrove Islands and the shoreline areas where the high water mark is less than 0.5m below top of the cliff or beach would be most affected. On land or on the island, differences in slope would allow different extents of flooding in different parts of the study area (Table 4.2). With the death of mangroves and change in tidal levels, changes in sedimentological processes would occur.

SEDIMENT COMPOSITION

The surface sediments of Shirazi-Funzi lagoon were found to comprise quartz, carbonate minerals and organic matter. Except at the tidal inlet where coral reef fragments are formed, the sediments of the lagoon are dominated by quartz sand which ranges from 90 to 95 per cent in most parts of the lagoon, especially in the channels and mangrove islands. Carbonate minerals occur at 2.7 per cent on average, except at tidal inlet where it is more than 86 per cent.

Table 4.3 *Results of salinity and POC analysis for samples from Kiwambale sampling station, Mamuja channel.*

East African Time (hrs)	Salinity (Parts per thousand)	POC ($\mu\text{gC/l}$)	Estimated Tide Level (m)
18.00	35.05	1740	2.75
20.00	34.51	1035	1.30
22.00	33.42	1275	0.63
00.00	35.05	1385	0.78
02.00	35.45	645	2.13
04.00	35.95	645	3.23
06.00	35.34	1160	3.10
08.00	35.23	1390	1.55
10.00	34.14	1035	0.35
12.00	33.78	1480	0.40
14.00	35.95	1965	1.50
16.00	35.95	1095	3.05
18.00	36.91	1315	3.06

Figure 4.1 24hr variation in tidal level, POC, and salinity of surface water at Kiwambale in Mamuja channel

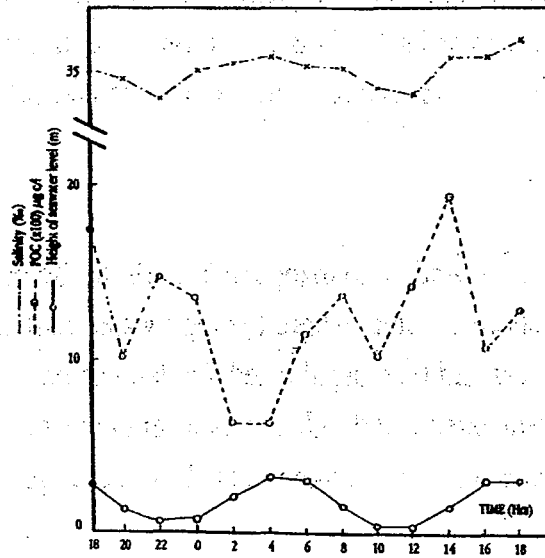

Figure 4.2 Variation of mean grain size, sorting, skewness and kurtosis of sediments along Mamuja channel

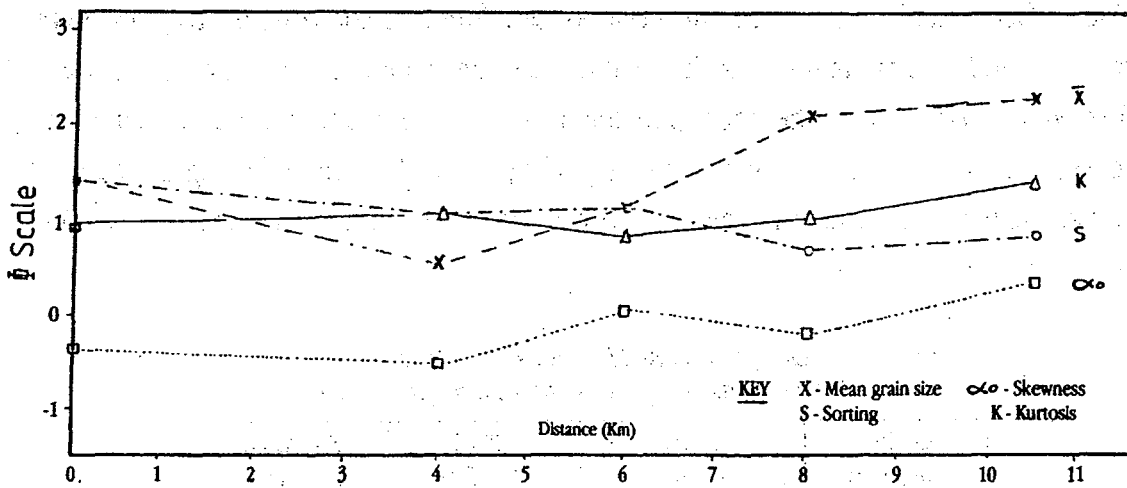

Figure 4.3 Exponential dissipation of energy by waves entering Uvinje and Mamuja channels

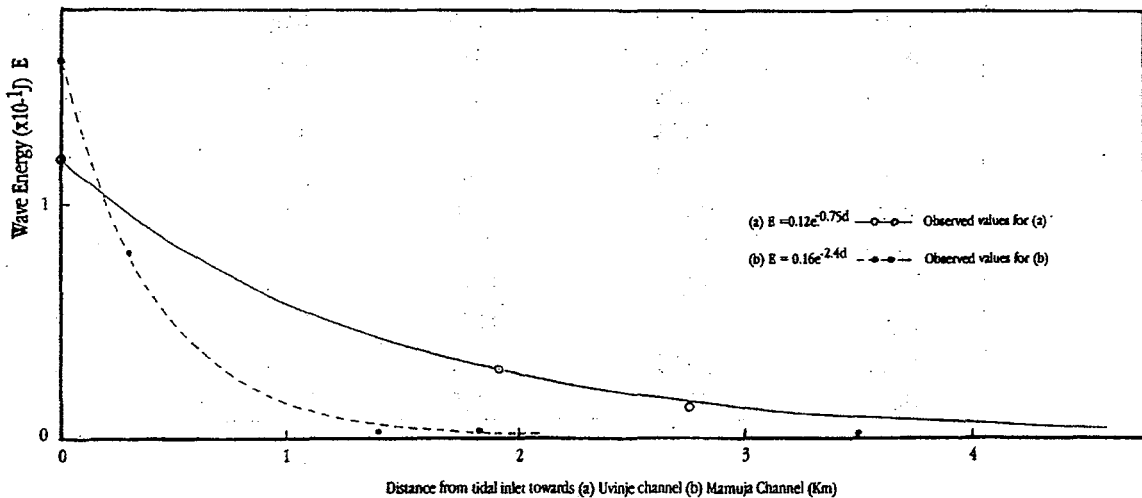

Table 4.4
General properties of sediments of Uvinje channel of Shirazi-Funzi lagoon

	Phi-Scale	Comment
Mode	2.47	Fine sand.
Mean grain size	2.07	Fine sand.
Median	2.15	Fine sand.
Standard deviation	0.559	Grains moderately spread around the mean.
Sorting	1.35	Poorly sorted.
Skewness	0.025	Negatively skewed.
Kurtosis	1.025	Mesokurtic.

Total organic carbon was found to average 1.87 per cent in the sub-aqueous environment, but at edges of mangrove islands, it exceeded 50 per cent.

PARTICULATE ORGANIC CARBON IN SUSPENDED MATTER

In the 24-hr period, POC was found to be high in the channel (Table 4.3) with highest values being observed during tidal ebbs, when Ramisi River water level was highest as shown by low salinity values (Fig 4.1). There was a sharp increase in salinity between 12 hr and 18 hr, probably due to higher rate of evaporation during day time.

SEDIMENT GRAIN SIZE DISTRIBUTION

Sediments along the Uvinje Channel comprise fine sand, and show an even distribution (Table 4.4). In the Mamuja/Ramisi Channel, there is a slight decrease in mean grain size in the seaward direction while at the same time, sorting changes from poor to moderately well sorted. There is a change in skewness from very negatively skewed to positively skewed, implying a tendency from coarser to finer sand grains. In the channel, distribution is generally mesokurtic, but becomes leptokurtic at the mouth of channel implying a tendency towards dominance of finer sand grains (Fig 4.2).

DISCHARGE OF SUSPENDED MATTER BY RAMISI RIVER

Average annual discharge of water was found to be 5.20×10^7 m³/yr, while the average amount of suspended matter was found to be 2.95×10^{-2} kg/m³. The approximate annual discharge of suspended matter was found to be 1534 tonnes/yr.

HYDRODYNAMICS

Wave Energy

Wave energy is greatest at the tidal inlet, where wave heights are highest. Fig 4.3 shows that a wave entering the lagoon through the tidal inlet dies out exponentially after which it becomes less effective in maintaining sediments in suspension during which transportation may occur due to water currents. However, it appears that due to the effects of water discharges by Ramisi River, wave energy entering the Mamuja Channel dies out faster than that entering Uvinje Channel, resulting in more defined sediment shoaling at the channel mouth.

Currents

Tidal currents are the main currents experienced in the lagoon. Due to the morphologic setting of the lagoon, wind energy appears to be less important in terms of current generation.

HUMAN ACTIVITIES AND SEDIMENTOLOGICAL PROCESSES

The main economic activities for local inhabitants were found to be mangrove harvesting and fishing. Mangroves are harvested and used as fencing poles and construction materials, fuel wood and are also sold to users who are non-harvesters to generate income. Fisheries resources are harvested for food and trade to generate income. Problems cited by local inhabitants as caused by mangrove harvesting are shoreline erosion in the lagoon and destruction of fishing grounds for fish, which result in low catch of fish. They cited mainland

Table 4.5 *Exploitation of mangrove and fish resources in the Shirazi-Funzi lagoon*

	Mangrove Exploitation	Fisheries Resources
Av. daily harvest	24.6 scores (a)	175.4 kg
Av. price	sh.62.6 /score	by size (b-c) large: sh22.00 /kg medium: sh12.00 /kg small: sh 4.00 /kg
% of harvesters	58.6	72.4
Av. distance from harvester's home to the lagoon (km)		3.2
Av. family size		5

(a) 1 score = 42 mangrove poles.

(b) Prices are for fish species only. Prices of crustaceans ranged from sh.60.00 - 150.00 /kg.

(c) Fish sizes depending on length and species.

Table 4.6
Correlation matrix for socio-economic activities in the Shirazi-Funzi lagoon

	V1 *	V2	V3
V2	-.2566	-	
V3	.3042	-.1575	-
V4	-.3619	-.3493	.0594

- * V1 - Fisheries (kg.) V2 - Distance from respondent's home to the lagoon.
V3 - Family size. V4 - Mangrove harvesting. (scores)

trees as an alternative resource for fuelwood and construction material, although the mangroves are the main source of fuelwood for all the families, and there are no indigenous or exotic forests in the area. Problems cited as due to fishing were few and include fishing of fingerlings due to use of the wrong nets. Table 4.5 is a summary of mangroves and fisheries harvesting activities in the lagoon. From the table of correlation (Table 4.6), it appears that fishing tends to increase more with increase in family size as compared to mangrove harvesting. The number of people who depend on the lagoon's resources appears to decrease further away from the lagoon, while fishing appears to increase as mangrove harvesting decreases. Other activities that were observed are small scale farming for subsistence needs, transport of inhabitants by use of boats from mainland to Funzi Island, and one tourist club at Funzi Island. These activities, including transport of mangroves from Bodo dhow harbour, have rendered the harbour an erosive environment as it is the main entry and exit point to and from the lagoon and island.

Discussion

Shirazi-Funzi lagoon is a terrigenous setting, with sediments that are largely characterised by quartz grains. Transport of sediments to the lagoon is mainly by water. Sediments are transported from the land, while a part of them are generated during coastline erosion, and falling of mangrove leaves and trunks which upon decomposition, produce the organic part of the sediments. The morphological set-up and presence of thick mangrove cover provides a healthy fish spawning environment. Hydrodynamic energy within the lagoon is low, allowing continuous sediment accumulation which is more pronounced along and at the mouth of Mamuja Channel. Generally, the lagoon would experience high impacts of sea-level rise, as there would be landward shift of the intertidal zone, and partial covering of the island by sea water.

The high POC values at Mamuja Channel during tidal ebbs indicate that the Ramisi River

may be contributing large amounts of particulate matter into suspended matter, the other part being derived from the mangrove environment. Dead plankton, which is part of POC (Parsons *et al.*, 1984) may form part of the organic nutrients contributed by the river and mangrove environments to the general ecosystem.

The main environmental problems identified in the study area were sediment shoaling in channels and coastline erosion. Sediment shoaling is occurring because current and wave energies are not strong enough to effectively transport sediments seaward. As a result of shoaling, changes in the directions of currents and waves have favoured shoreline erosion.

Although sediment shoaling may be contributing to erosion along the shoreline, human activities contribute more to shoreline erosion, through harvesting and transporting mangroves in parts that are exposed to relatively high currents and wave energies. Along Funzi Island shoreline, buildings are highly at risk because shoreline erosion appears to be faster after removal of the thin strip of mangroves along the shoreline. Fishing activities do not appear to pose much danger except at some unprotected landing sites.

In order to solve the above environmental problems there is need to:

- apply soil conservation measures in areas which are sources of sediments to the lagoon, such as the catchment area of Ramisi River;
- relocate endangered structures on Funzi Island;
- carry out detailed research on coastal erosion in order to develop suitable defence mechanisms; and
- develop policies aimed at controlling dependence on, and methods of harvesting mangrove resources by local inhabitants.

Conclusion

Shirazi-Funzi lagoon is a mangrove ecosystem, dominated by sediments that are largely terrigenous. Water discharged into the lagoon by the Ramisi River may be one of the main ways through which food for the organisms in the ecosystem is replenished in the form of particulate matter. Due to mangrove cover and low hydrodynamic energy, the lagoon provides healthy productivity conditions for fisheries resources.

Human activities, shoreline erosion - especially along Funzi Island, continuous deposition of sediments, and proneness of the lagoon to impacts of global-warming-induced sea-level rise are environmental threats to the lagoon as an ecosystem. Although it appears that increased fishing can result in decrease in mangrove harvesting, research and policies are required on how to manage the exploitation of resources of Kenya's coastal lagoons.

Abstract

The aims of the study were to determine (i) factors that affect the sedimentology of the Shirazi-Funzi lagoon; (ii) sediment mineralogy and source environments; (iii) economic importance of the lagoon; (iv) environmental problems within it; (v) possible management policies for Kenya's coastal lagoons. Sediment grains distribution, composition and dynamics were studied; suspended sediment discharge by Ramisi River was determined, and POC was studied to investigate possible contribution of the river to nutrient replenishment in the lagoon. Geomorphology, hydrodynamics and socio-economic activities were also studied.

The lagoon is dominated by terrigenous sediments, comprising mostly of fine quartz sand. Grain size diminishes gradually from mainland shoreline towards the tidal inlet. Carbonate mineral content ranges from 0.01 to 5.0% by weight in most parts of the Lagoon, but adjacent to the coral reef, it increases to over 80% by weight. Total organic matter content ranges between 0.01 to 2.0% by weight in the channels, but increases to over 50% by weight at channel banks, and decreases to minimum levels towards the centre of the mangrove islands. Cliffs, beaches, channels, sandbars and mangrove islands are the physiographic features of the lagoon. Off the lagoon, sea-wards is a trough, due to Pemba channel, with a maximum depth of 207m. Wave energy is dissipated exponentially from the tidal inlet toward mainland shoreline. Annually, Ramisi River discharges about 1.534×10^3 tons of suspended matter. POC of surface water at Mamuja channel ranged from 645 mgC/l to 1940 mgC/l in 24 hours, the highest values occurring during tidal ebbs. The main socio-economic activities in the lagoon are fisheries and mangrove exploitation. The rate of harvesting of fisheries resources is negatively correlated with that of mangrove resources. The main environmental problem in the lagoon are shoreline erosion, lagoonal sedimentation, mangrove felling and vulnerability of the lagoon to global-warming-induced sea-level rise. Policies are suggested, which require research-based data, on management of Kenya's lagoons, in light of the observed environmental problems.

Acknowledgements

I am grateful to Moi University for offering me a M.Phil. scholarship and enabling completion of the thesis of which this paper is a part. I am particularly grateful to Prof. M.P.Tole for tirelessly supervising and encouraging me throughout the study period. I also thank the members of staff of School of Environmental Studies, Moi University, and those of Kenya Marine and Fisheries Research Institute, who assisted me directly or indirectly during the study.

References

- Cannon R T, Simiyu S W M N & Karanga F M (1981). The Proto-Indian Ocean and a probable Palaeozoic/ Mesozoic triradial rift system in East Africa. *Earth and Planetary Science Letters*, 52, 419-26.
- Caswell P V (1953). *Geology of the Mombasa-Kwale area*. Geological Survey of Kenya. Report no. 24.
- Dyer K R (1986). *Coastal and estuarine sediment dynamics*. New York: John Wiley.
- Hakanson L & Janson M (1983). *Principles of lake sedimentology*. Berlin/Heidelberg: Springer.
- Munyao T M (1992). *Sedimentology of Shirazi-Funzi Lagoon, Coast Province, Kenya*. M.Phil. thesis, Moi University, School of Environmental Studies.
- NES (1985). *District environmental assessment report; Kwale District*. Nairobi: National Environmental Secretariat/ Ministry of Environment and Natural Resources.
- Parsons T R, Maila Y & Lalli C M (1984). *A manual of chemical and biological methods for sea water analysis*. New York: Pergamon Press.
- Rais-Assa R (1987). Stratigraphy and geodynamics of the Mombasa Basin (Kenya) in relation to the genesis of the Proto-Indian Ocean. *Geological Magazine*, 125 (2), 141-147.

GROUNDWATER RESOURCES AND SEA WATER INTRUSION IN KWALE DISTRICT

S.O. ANYANGO, M.P. TOLE AND E.K. UCAKUWUN

Introduction

Although Kenya straddles the equator like the Amazon Basin, it has nothing near the equatorial vegetation of the latter region due to altitude and monsoons, resulting in great variations in rainfall patterns. Roughly four-fifths of Kenya is semi-arid or arid. This covers all areas from the shrub of the coastal region to the northern semi-desert region (Camponera, 1979). The open water resources in lakes, rivers and dams constitute 11,230 km². In addition, Kenya receives an average annual rainfall of 567 mm converting to 323 billion m³ of water (GoK, 1989). These limited resources need to be properly harnessed and conserved.

The problems of water resource management emerge at two critical levels. Firstly, the resources are limited and subject to competing demands from human settlement both in urban and rural areas. This is demonstrated by the frequent shortages in the major urban

Figure 5.1 Concentration of chloride in boreholes in Diani-Tiwi area

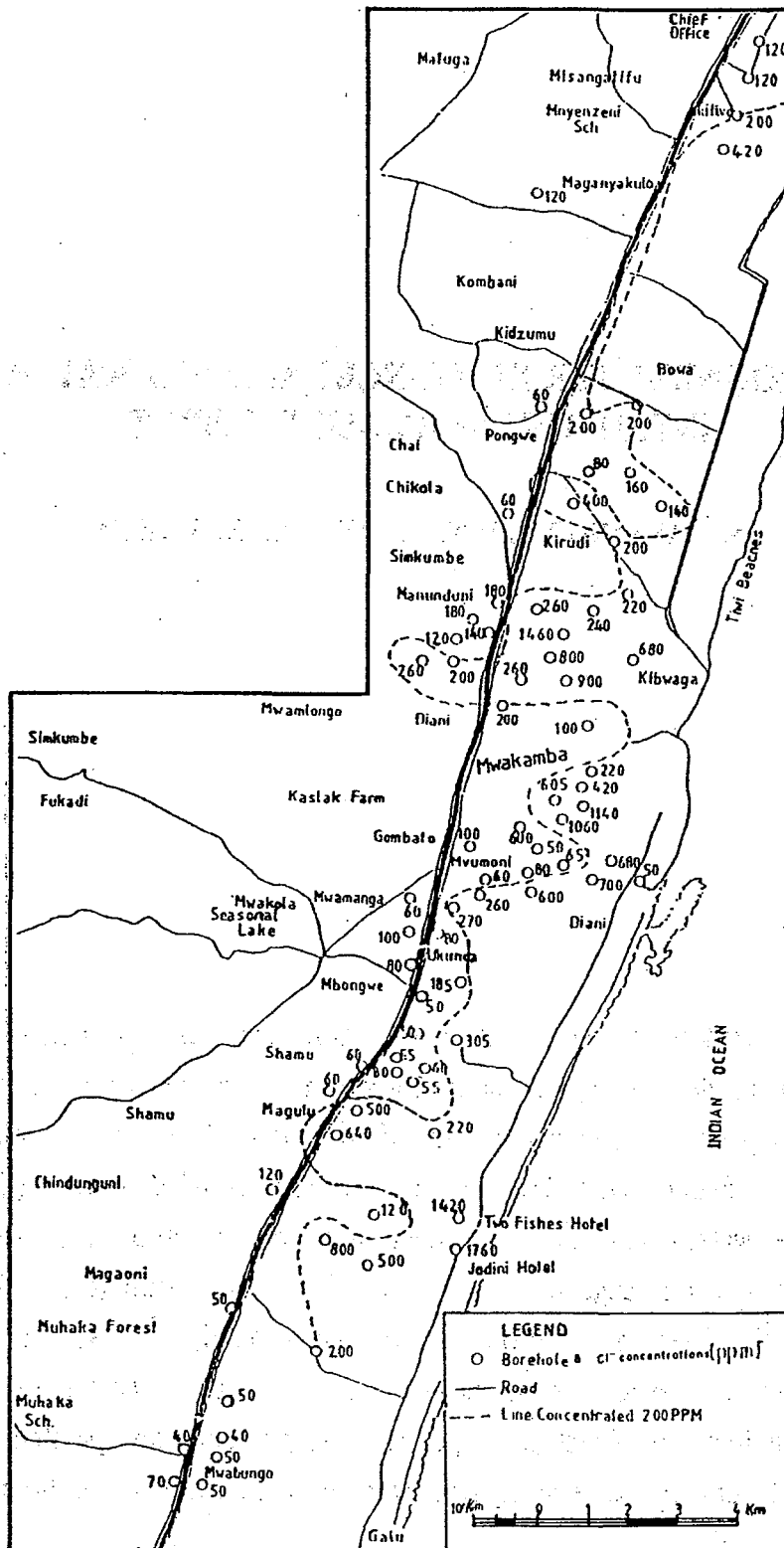

centres and in rural areas where women and children have to walk long distances to fetch water. This calls for appropriate measures for resource allocation. Secondly, resource utilisation and human activities may have adverse impacts on water quality and it is therefore essential that water utilisation and quality be managed.

Kwale District lacks adequate water resources. Several seasonal springs from the Shimba Hills catchment area and a few seasonal rivers in the south coast are some of the sources of water. According to the studies done in the area by the Ministry of Water Development and other studies, the area has potential for groundwater exploitation. But the development of groundwater resources requires carefully controlled pumping, accompanied by proper operation surveillance (Chapman, 1992).

The present trends in groundwater exploitation have not differentiated between renewable and non-renewable resources. The determination of maximum and minimum water levels in order to regulate storage capacity is important (Balek, 1983). A decrease in groundwater levels due to excessive pumping besides causing permanent damage to the stability of the groundwater storage, increases the cost of further pumping, facilitates salt water migration and the pollution of the aquifers with sea water (Balek, 1983).

The present study was carried out to determine the extent of groundwater exploitation and its effect on water quality in Kwale District. The area hosts a chain of tourist hotels and due to frequent water shortages from the main pipeline, most of them have drilled boreholes from which they extract large amounts of water. In addition, the National Water Pipeline and Conservation Corporation (NAWACO) is operating several boreholes and the Kwale Water and Sanitation Project (KWASP) has come up with an extensive network of shallow boreholes to provide water to the rural population. It is quite possible that extraction may by now surpass recharge, hence causing depletion of groundwater and resulting in sea water intrusion.

This study was conducted to determine:

- The groundwater quality from public supply sources threatened by sea water intrusion;
- Whether the tidal changes have an effect on the quality of groundwater;
- The sustainability of water facilities established in the area;
- The hydrogeochemical correlation which may be prevailing in the study area.

Materials and Method

FIELD METHODS

Water samples were collected from 125 points, consisting mainly of boreholes and open dug wells. At each point, samples were collected twice at different times. Each sample was

analysed in duplicate. The specific conductivity, temperature and pH were determined in the field using automated instruments (probe meters).

Polyethene bottles were used for the collection of samples. They had screw cap stoppers to prevent leakages during transportation. The containers were pre-cleaned with metal-free nitric acid and then rinsed several times with glass distilled water. Samples from boreholes were taken after the water was allowed to flow for 3 to 5 minutes after the pumps were in operation. This was to ensure that a representative sample of the source was taken.

Analysis was carried out the day following sampling to ensure that there was no significant change in the concentration of the parameters to be determined. The samples were then stored in a cold storage at about 4°C for future reference if need arises. Methods applied in the analysis were basically those used by the Kenya Government Chemist Department (water section). The parameters determined are TDS (Total Dissolved Solids), Potassium, Sodium, Calcium, Total Hardness, Magnesium, Alkalinity, Chloride, Hydrogen Carbonate, Fluorides and Silicon.

Some specific sampling points were selected and water quality monitored by taking water samples and measuring the depth of the open well after every one hour throughout the cycle of the tide (from low to high and to low).

DATA ANALYSIS

The data was treated to correlation analysis procedures to determine relations between parameters.

Hydrological data analysis involved the plotting of the locations of all the boreholes in the study area. Borehole data on aquifer depth and the water rest levels were then used to depict the water flow directions. Hydrogeochemical data analysis involved preparation of a contour on a map to depict the area of sea water intrusion using chloride concentrations.

General classification of the water was done using the classification adopted from Davis and Dewest (1970). Possible increase in sea water intrusion was investigated by checking for significant increase of chloride and sodium concentrations by comparing the initial data (from KWASP) and the data obtained in the study. Graphs of water rest levels against time and height of tides in the ocean were produced to depict the influence of tidal changes on the selected wells near the ocean. Salinity classification and calculation of Sodium Absorption Ratio (SAR)¹ served to determine the suitability for irrigation purposes.

1. $SAR = Na^{2+} / \sqrt{((Ca^{2+} + Mg^{2+})/2)}$, where Na^{2+} , Ca^{2+} and Mg^{2+} represent the concentrations, in

Table 5.1 Classification of water on the basis of TDS by catchment area*

Type of water	Recommended TDS range in ppm.	distribution		
		Diani %	Msambweni %	Tiwi %
Fresh	below 1,000	63	96	81
Brackish	1,000 - 10,000	35	4	19
Salty	10,000 - 100,000	2	0	0
Brine	above 100,000	0	0	0
		100	100	100

* Modified from Davis and Dewiest, 1970

RESULTS²

WATER QUALITY

The distribution of the sampling sites is shown in Fig 5.1 & 5.2. According to the classification in Table 5.1, most areas have fresh waters. Diani catchment has the highest percentages of brackish water. Most of the parameters were below the maximum permissible levels for drinking water apart from conductivity, total dissolved solids, sodium, chloride, magnesium and total hardness which, in some cases had very high values (Table 5.2).

Most of the boreholes with high levels of TDS are quite close to the ocean. Conductivity, TDS, Na and Cl show great variation between individual boreholes. This suggests that the factors influencing these parameters are not uniformly distributed in the area and do not necessarily derive from the geology of the area because this is the same throughout the study area.

The pH in the study area ranges between 6.5 and 8.18 while the means were 7.26, 7.15 and 7.28 for Diani, Msambweni and Tiwi respectively. The pH values in the three aquifer systems indicate generally neutral waters and within the range of most groundwater as reported by Hem (1978). The fluoride concentration was generally below the maximum permitted value of 1.5 ppm (WHO, 1987) with a mean value of 0.3, 0.2 and 0.3 ppm for Diani, Msambweni and Tiwi respectively. These results indicate that the water is generally suitable for drinking purposes. However, the water has limited use due to the general hardness.

About 90 per cent of the samples from Msambweni had conductivity less than 1000 μ s. The lowest value was recorded at Makalani and Chungwani 'B' (520 μ s) while the highest was 2600 μ s at Bahani. In Tiwi, about 53 per cent of samples had conductivity of less than

milliequivalents per litre of the respective cations.

2. Detailed results are presented in Anyango (1995).

1000 μ s. The lowest value recorded was 400 μ s (at Kombani) while the highest was 4800 μ s at Kayatiwi secondary school. Diani had the greatest variations resulting in the mean being even less than the standard deviation. About 57 per cent of the samples had conductivity of less than 1000 μ s. The lowest recorded values was 420 μ s while the highest was 15000 μ s at the Grand Reef Hotel in Diani.

Table 5.2 Physico-chemical parameters by catchment area (mean \pm s.d.)

	Diani N=55	Msambweni N=30	Tiwi N=32
Conductivity (μ s)	1701 \pm 2259	708 \pm 401	1296 \pm 915
Depth (m)*	31 \pm 12	18 \pm 7	33 \pm 12
Temp ($^{\circ}$ C)	30 \pm 2	31 \pm 2	31 \pm 2
pH	7.3 \pm 0.4	7.2 \pm 0.2	7.3 \pm 0.4
TDS (ppm)	1187 \pm 1521	598 \pm 596	910 \pm 634
K (ppm)	10 \pm 17	3 \pm 3	7.3 \pm 5
Na (ppm)	218 \pm 461	72 \pm 82	167 \pm 162
Cl (ppm)	413 \pm 809	130 \pm 167	287 \pm 292
Ca (ppm)	132 \pm 52	145 \pm 207	115 \pm 48
Mg (ppm)	31 \pm 31	24 \pm 60	24 \pm 21
Total hardness (ppm)	436 \pm 163	356 \pm 41	435 \pm 162
F (ppm)	0.3 \pm 0.6	0.2 \pm 0.4	3.8 \pm 21
SiO ₂ (ppm)	31 \pm 13	30 \pm 14	38 \pm 15
HCO ₃ (ppm)	332 \pm 95	323 \pm 40	341 \pm 71

* N=46; 25; 28 respectively

Table 5.3 shows the results of the comparison of the values in 1987 when the boreholes were dug with the results of the present study, in 1993. The figures confirm that the waters have become more saline and that there are significant changes in Conductivity, TDS and Na concentrations.

Analysis by means of the trilinear method (piper diagram) indicates that in Msambweni, 50 per cent and above of the water is dominated by calcium cations while 10 per cent of the samples have sodium as the dominant cation. For the anions 81 per cent of the water samples form a cluster indicating 50 per cent and above of bicarbonates as dominant and 10 per cent of the remaining waters have chloride as the dominant anion. In Diani about 42 per cent of the water samples form a cluster indicating 50 per cent and above of the waters is dominated by calcium while 35 per cent of the waters have sodium as the dominant cation. For the anion 55 per cent of the water samples form a cluster indicating 50 per cent and above of bicarbonate as dominant and 38 per cent of the remaining waters have chloride ion as the dominant anion. In Tiwi about 36 per cent of the water samples form a cluster indicating that 50 per cent and above of the water is dominated by calcium

while 30 per cent of the waters have sodium as the dominant cation. For the anion 39 per cent of the waters samples form a cluster indicating that 50 per cent and above of bicarbonate as dominant and 39 per cent of the remaining waters have chloride as the dominant anion.

Table 5.3 Results of selected parameters for boreholes measured in 1987 and 1993 (mean \pm s.d.)

	N	1987	N	1993	p= *
Conductivity	68	876 \pm 572	68	975 \pm 574	.03
TDS	65	579 \pm 416	65	688 \pm 401	.001
Na	45	86 \pm 91	45	115 \pm 104	.003
Cl	65	170 \pm 192	65	186 \pm 177	.13

* paired t-test; one-tailed

VARIATION OF CHLORIDE CONCENTRATION

Figures 5.1 & 5.2 show the concentration of chloride in various boreholes in the study area and also indicate the possible trend of Cl-ions which is related to sea water intrusion. There is an indication of inward movement of the sea water/fresh water interface. The chloride contour line gives the probable area of sea influence. The 200ppm value was chosen because water with higher values normally starts having a salty taste.

TIDAL AND WATER DEPTH VARIATIONS

These indicate that the wells have direct linkage with the sea, even though there is a time lag of one and a half hours between lowest tide and lowest height (Fig 5.3). When it is high tide the water rest level is increased. The effect is less and time lag greater (up to eight hours) for fresh water boreholes nearby. But the effect is greatest in boreholes near the ocean.

Table 5.4 Distribution of SAR values by catchment area (%)

	Diani N=50	Msambweni N=30	Tiwi N=32
0.0 - 0.9	40	40	6
1.0 - 1.9	20	40	22
2.0 - 2.9	4	3	28
3.0 - 5.9	20	7	31
6.0 - 8.9	12	10	10
9.0 +	4	0	3
	100	100	100

SODIUM ABSORPTION RATIO

Elevated sodium in certain soils can degrade soil structure thereby restricting water movement and affecting plant growth. Results for the sodium-absorption rate calculations for the three water catchment areas are presented in Table 5.4. Although the values are higher in Tiwi than in the other catchment areas there were no observations above the critical value of 18 (Driscoll, 1986). All samples have low values which makes the water suitable for irrigation purposes.

Discussion

The results of the water samples indicate that the chemical nature of groundwater in the study area is influenced by environmental factors e.g. the geology, chemical processes, climate and hydrological factors. This was also noted in studies by Maina (1981) and Ongwenyi (1973). The water in the study area can be classified into four types, calcium bicarbonate, calcium chloride, sodium bicarbonate and sodium chloride type of waters.

The fluoride concentration was generally below the maximum permitted value of WHO (1.5ppm) with a mean value of 0.3, 0.2 and 0.3 for Diani, Msambweni and Tiwi areas respectively. This indicates that the water presents no danger due to fluorides. Fluoride mobility in water depends to a large extent on the Ca^{2+} ion concentration since fluoride forms low solubility compounds, with divalent cations. This explains why the water in the study area may have low fluoride concentrations.

The cases with Na^+ as the dominant cation can be attributed to the influence of the sea, through the process of sea water intrusion. Examples are boreholes at Jumapili, Baharini and Mkaliatsi in Msambweni; boreholes at Maweni, Bwagamoyo at Jadini hotel in Diani; and boreholes at Sparki, Shukrani and Tawakal in Tiwi (Fig 5.1). In Msambweni a tongue of sea water seems to be coming in from the south (Mto Kivinje, Fig 5.2). In Tiwi and Diani several tongues of sea water intrusion were observed at Bowa, Kibwaga, Mwakamba, Magutu among others.

Compared with measurements that were taken in 1987 when the boreholes were sunk, the present study, in 1993, found no significant changes in Conductivity, TDS, Cl and Na concentrations, although there is a general trend towards greater salinity in the boreholes. According to Freeze and Cherry (1979), the rate of groundwater extraction that causes groundwater 'mining' is not necessarily the same as the rate that causes contaminant intrusion. In coastal areas for example a certain rate of groundwater extraction, even without causing over withdrawal, can lead to sea water intrusion.

Figure 5.3 Tidal variations* as compared to the well water rest levels

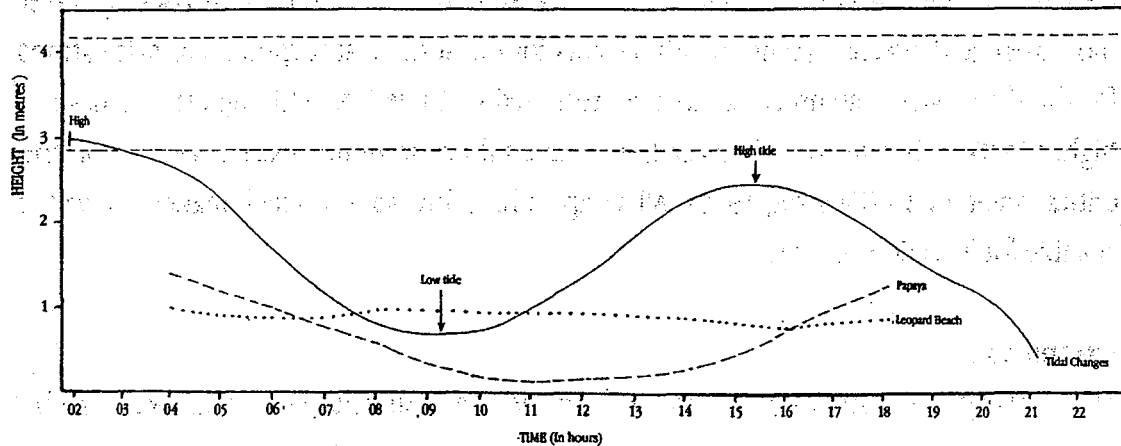

* The wells were monitored over 12 hours when no drawing of water occurred

There is a significant difference in the chloride concentrations in Diani & Tiwi compared to Msambweni. The reason might be due to more extensive borehole extractions compared to the Msambweni area. The Diani/Tiwi area has a higher population density with higher number of boreholes belonging to hotels and other private owners. These boreholes use electric pumps, thus extracting more water than the handpumped boreholes do. Some of the beach hotels have obtained the right of extracting water from boreholes further inland with fresh water and this has resulted in some of these boreholes becoming saline e.g. boreholes sunk by South Palms and Leisure Lodge around Diani and Mvumoni respectively.

In Msambweni, the extraction still seems not to have had effect on the aquifer except at Msambweni Hospital and near the creek at Shirazi and there are no signs of sea water intrusion. Fresh water springs in the intertidal zone have been observed in the Msambweni area, confirming a high fresh water recharge. Such a phenomenon can no longer be observed in Diani or Tiwi.

In Diani, some boreholes are already highly saline, especially those being operated by the hotels, but no precautionary measures have been taken to protect the nearby boreholes that are producing fresh water. This can encourage the sea water/freshwater interface to move further inland. Some wells have become saline to the extent that the water is no longer being used for domestic purposes (e.g. Kwa Mzee Juma Makalani in Diani).

The study established that the sea water/freshwater interface varies along the coast but it ranges from 1.5km to 6.5km from the shoreline in the Mwabungo-Waa area. In the Msambweni area, the waters are safe for drinking up to the shoreline except adjacent to Msambweni hospital and south Kigwede in the Shirazi area.

The study indicates that wells have direct linkage with the sea, even though there is a time lag of one and a half hours between lowest tide and lowest height. When it is high

tide the water rest level is increased, the effect is less and the time lag greater (up to eight hours) for a freshwater borehole nearby. But the effect occurs only in some specific boreholes near the ocean.

Without the threat from sea water intrusion, it is evident that the freshwater in the area is generally potable and suitable for domestic use. The water has also low SAR value and therefore suitable for irrigation. However, sodium sensitive crops may accumulate injurious sodium concentrations and Driscoll (1986) recommends that most of these waters are used on textured organic soils with good permeability.

Conclusion

This study has shown that the sea water intrusion is significant at the present level of groundwater extraction. A good groundwater management plan should be developed for these major aquifers. The following measures can be useful in the conservation and proper utilisation of these resources:

- Determination of aquifer safe yields;
- Monitoring of groundwater levels and well allocation, spacing and construction guide lines;
- Records of water use rates, quantities and quality should be maintained by large scale users such as hotels and even the National Water Pipeline and Conservation Corporation. Such records can help water managers to decide (where the safe yield of an aquifer is already determined), whether or not withdrawal is excessive so as to take appropriate measures, such as reducing the quantity under the license;
- Discourage hotels from using fresh groundwater in the area, and propagate other methods like desalination (some are already doing it e.g. Jadini) and roof catchment;
- Encouraging rainwater harvesting in general, much more than has been done so far. This can reduce the pressure on the limited groundwater resources, and provide a long term solution for the area.

However, enactment of good regulations and subsequent enforcement are fraught with difficulties involving political, economic and sociological factors that are hard to overcome.

Abstract

This work describes the results of water quality analysis carried out along the coastal plains of Kwale District, to determine the influence of sea water intrusion, the relationship between tidal changes and water quality in boreholes close to the sea shore, and the effectiveness of the hand pumps in the provision of potable waters in the study area.

Four types of waters were found in the study area; calcium bicarbonates, sodium bicarbonate, sodium chlo-

ride and calcium chloride waters. Total Dissolved Solids (TDS) in sodium-rich waters varied from 800ppm to 10,000ppm with most of the TDS concentrations being below 1000ppm (recommended concentration limits for drinking water). The salinity hazards for the water are greater than $750\mu\text{s}/\text{cm}$ at 25°C . Consequently this water has limited practical use.

A salt tongue (sea water intrusion) was detected covering a distance ranging from 1.5 to 6.5km from the shoreline in Mwabungo-Waa area. But in the Msambweni area, sea water intrusion is still limited and waters are safe for drinking up to the shoreline except adjacent to Msambweni hospital and south Kigwede in the Shirazi area.

During periods of high tide some wells exhibit higher levels of water and higher salinity than during the time of low tides. This effect decreases with distance away from the seashore.

Acknowledgements

This study was carried out as part of an M.Phil. thesis for the first author. Funds from the Kenyan Government, through the school of Environmental Studies, Moi University enabled the field work to be undertaken. We acknowledge the use of facilities of Government Chemist Department Mombasa and Kwale Water and Sanitation Project (KWASP).

References

- Anyango S O (1995). *The chemistry and management of the ground water resources in Kwale District, Kenya, with reference to sea water intrusion*. M.Phil. thesis. Moi University, School of Environmental Studies.
- Balek L (1983). *Hydrology and water resources in tropical regions*. New York: Elsevier
- Camponera D (1979). *Water law in selected African countries*. Rome: FAO.
- Chapman D (1992). *Water quality assessments: A guide to the use of biota, sediments and water in environmental monitoring*. London: Chapman and Hall.
- Davis S N & Dewiest R J M (1970). *Hydrogeology*. New York: John Wiley.
- Driscoll F G (1986). *Groundwater: water and wells*. 2nd ed. St. Paul (Minnesota.): Johnson.
- Freeze RA and Cherry J A (1979). *Groundwater*. Prentice Hall.
- GOK (1989). *Kwale District development plan 1989-1993*. Nairobi: Government of Kenya, Government Printers.
- Hem D J (1978). *Study and interpretation of the chemical characteristics of water*. United States Department of the Interior, 1473.
- Maina J W (1981). *Groundwater chemistry of the area to the immediate North of Nairobi conservation area*. M.Sc. thesis. University of Nairobi.
- Ongwenyi G S (1973). *The significance of the geographic and geologic factors in the variation of groundwater chemistry in Kenya*. M.Sc. thesis. University of Nairobi.
- WHO (1987). *GEMS/Water operational guide*. Geneva: World Health Organization.

THE IMPACT OF GEOLOGY AND PIT LATRINES ON GROUND WATER QUALITY IN KWALE DISTRICT

J. M. MZUGA , M.P. TOLE & E.K. UCAKUWUN

Introduction

The composition and state of an aquatic environment shows temporal and spatial variations due to factors internal and external to the water body (Chapman, 1992). Pollution of the aquatic environment is the introduction, directly or indirectly, of substances or energy which result in such deleterious effects as: harm to living resources; hindrance to aquatic activities including fishing; hazards to human health; impairment of water quality with respect to its use in agriculture, industry and other economic activities; and reduction of amenities (GESAMP, 1988).

In this study the water quality of groundwater in selected areas of Kwale District was determined with respect to the local geology and human settlement. The study had the following objectives:

Figure 6.1 The direction of water flow with sampling stations

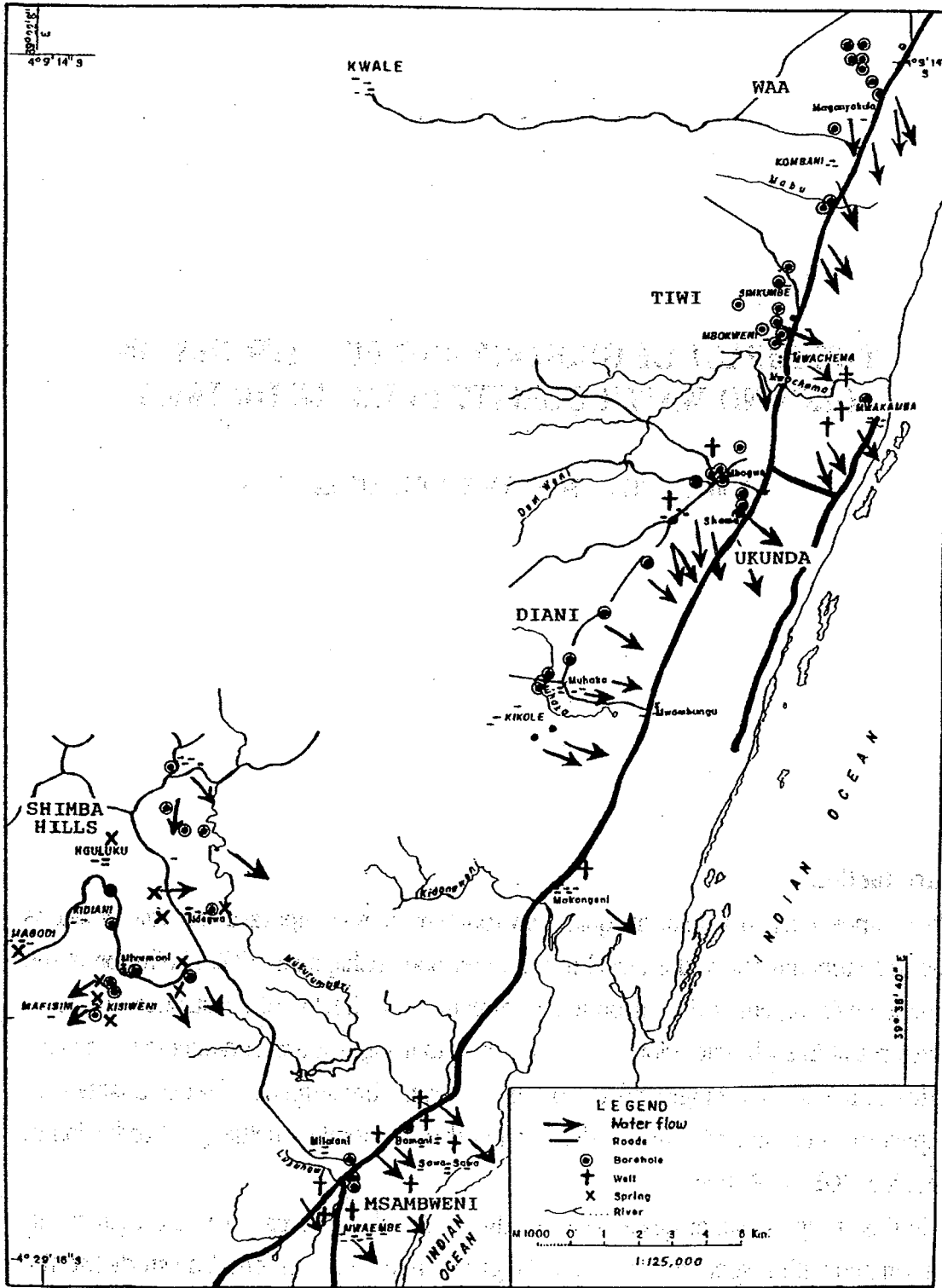

- To determine regional groundwater quality variations in relation to natural processes;
- To determine trends in groundwater quality in relation to pit-latrines location and to use the observed trends as a basis for informed decision making;
- To develop an understanding of regional groundwater quality as an aid to better knowledge of the ground water regime for optimal management, especially water for human consumption;
- To assess the effect of geology on susceptibility to contamination.

Study Area

Kwale District is one of the six districts of Coast Province and is situated in the southernmost part of Kenya along the Indian Ocean. The area of study extends some 10km inland from the coastline and is bounded by latitudes 4°09' and 4°19'S and longitudes 39°22' and 39°35'E. The area includes study locations in four regions: Diani/Ukunda and Tiwi/Waa which straddle a coral limestone aquifer; Msambweni and Shimba Hills which are situated on a sandstone aquifer (Fig 6.1).

WATER RESOURCES

Kwale District lacks adequate surface and underground water resources (Kwale District Development Plan, 1989-1993). There are only two reliable surface water sources both of which are to the north of the District and these are the rivers Ndlovuni and Cha Simba (Pemba). Several seasonal springs from the Shimba Hills catchment area and a few seasonal rivers in the south are the other sources of water. Water is therefore a priority problem for many communities and especially in the hinterland where women have to travel very long distances to fetch water from dams in the dry season. Swedish International Development Agency (SIDA) and Kenya Water for Health Organisation (KWAHO) have undertaken the installation of community owned handpumps along the coastal zones and rehabilitation of dams in the hinterland. The Kwale Water and Sanitation Project (KWASP) was started in 1985 as an extension of the then South Coast Handpumps Testing Programme (SCHP). It has the following activities:

- Drilling of boreholes and installation of handpumps;
- Protection of perennial springs;
- Construction of rain water roof catchment tanks;
- Assistance to self-help groups on piped water supply schemes;
- Construction of ventilated improved pit (V.I.P) latrines for demonstration purposes;
- Health education campaigns.

Table 6.1 *Number of boreholes, wells and springs sampled by region*

	Boreholes N=55	Wells N=13	Springs N=10
Diani/Ukunda	19	6	0
Msambweni	4	7	0
Shimba-Hills	12	0	10
Tiwi/Waa	20	0	0

Table 6.2

Average seasonal comparison of physico-chemical parameters (mean \pm s.d)

	Wet Season	Dry Season
pH	6.6 \pm 0.79	6.6 \pm 0.84
Temp ($^{\circ}$ C)	28 \pm 1.36	28 \pm 0.9
Cond (μ s/cm ³)	687 \pm 678	706.7 \pm 704.8
[O] (ppm)	0.95 \pm 1.4	0.6 \pm 0.44
COD (ppm)	153 \pm 116	151 \pm 67
BOD (ppm)	1.7 \pm 1.3	1.7 \pm 1.3
TSS (ppm)	0.0079 \pm 0.0079	0.0061 \pm 0.0047
TDS (ppm)	481 \pm 479	487 \pm 471
K (ppm)	4.2 \pm 3.7	4.1 \pm 3.4
Na (ppm)	32.9 \pm 23.8	37 \pm 30
Cl (ppm)	108 \pm 63	175 \pm 171
F (ppm)	0.19 \pm 0.11	0.3 \pm 0.2
Ca (ppm)	66 \pm 49	74 \pm 49
Mg (ppm)	9.9 \pm 9.4	17 \pm 16.4
SO ₄ (ppm)	10.6 \pm 9.6	10.4 \pm 9.4
Total coliform	8.86 \pm 7.8	6.3 \pm 6.1
E.Coli	0.36 \pm 0.33	0.14 \pm 0.11

Materials and Method

FIELD WORK

Preliminary survey

A preliminary survey of the study area was carried out in August 1993. During this period existing data on groundwater were collected; this was used to identify the principal features of the natural ground water quality in the defined area and to provide a basis for comparison to establish changes over time as an indication of possible geological influence.

Sampling

A total of 55 boreholes, 13 wells and 10 springs were sampled (Table 6.1).¹ Selection of sampling stations near pit latrines was done. The stations were sampled both during the wet (short rains) and dry seasons. The water samples were collected into clean 500ml plastic bottles, after cleaning using 0.1M HNO₃ (aq) and thereafter rinsing three times with the water to be sampled. Samples were collected from each borehole using a hand-pump, pumping at least three casing volumes of water to waste before collection. In wells, collection was done by lowering a weighted bottle (bottle with weights inside to facilitate sinking) down to the water level while in springs, samples were collected from the pipe from the reservoir.

ANALYTICAL METHODS

Dissolved oxygen, pH and conductivity were measured on site using a pH meter [Jenway Model 3100], oxygen meter [Jenway Model 9010] and a conductivity meter [Jenway Model 4070] respectively. A temperature probe attached to the pH meter was used to measure temperature. Chemical oxygen demand was determined by the dichromate reflux method. Biochemical oxygen demand (BOD) was determined by the difference in Dissolved Oxygen on incubation of the sample for five days. Aeration was done using an aerator before incubation (APHA, 1985).

Total suspended solids (TSS) were analysed by filtering 100ml of sample using 0.45 μ m filter paper then drying the filter paper with solids in an oven at 60°C for 30-50 minutes then weighing. Total dissolved solids (TDS) were determined by evaporating to dryness 100ml of sample at 105°C in an oven. The weight was obtained by the weight difference method.

1. The exact locations are given in Mzuga (1995).

Titrimetric methods were used to analyse the calcium, magnesium, chlorides and carbonates/hydrocarbonates. The flame photometer was used for analysis of potassium (K) and sodium (Na) while for sulphates (SO₄), a turbidimeter was used. For fluoride (F), a colorimeter method was used using zirconyl chloride and sodium alizarin.

A multiple tube method, the 'Most Probable Number Method' (MPN), was used to analyse coliform counts. Rapid detection of E. Coli was carried out for each presumptive positive tube from the coliform count test.

Results²

Means for the concentrations of physico-chemical parameters for the seasonal comparison are shown in Table 6.2. The results showed a slight increase in mean concentrations during the dry season for most parameters i.e. conductivity, TDS, Cl⁻, F⁻, Ca²⁺, sulphates, with means 706.7, 487, 175, 0.3, 74, 10.4 respectively. The pH showed no change, with a mean of 6.63, while dissolved oxygen, COD, BOD, and coliform counts showed a decrease with means 0.64, 151, 1.66 and 6.3 respectively.

Tiwi-Waa waters are Ca-Mg/Cl-HCO₃, while Diani/Ukunda waters are mainly Ca/Cl-HCO₃. A unique observation was made in two sample stations that had 58-65% sodium and over 80% chloride, and are thus Na-Cl waters. Shimba-Hills waters are Ca/Cl-HCO₃ except for two samples which showed a high Na:Cl ratio. Shimba-Hills springs have mainly Ca-Na-K/Cl-HCO₃ waters. Again two stations show unique Na:Cl ratio with 90% Chloride/70% sodium and 68% chloride/95% sodium respectively. Msambweni waters are Ca/Cl-HCO₃ with less than 50% sodium.

Diani region has highest mean for both conductivity and TDS followed by Tiwi/Waa region, Msambweni and Shimba Hills respectively (Table 6.3). In this area the groundwater flow is generally either easterly or southerly, therefore boreholes found towards this discharge zone should have higher concentrations of dissolved salts (TDS) as shown in Fig. 6.1.

Table 6.3 Specific conductivity and TDS.

	Diani/Ukunda	Msambweni	Shimba Hills	Tiwi/Waa
Mean TDS (ppm)	990	293	227.5	503
Mean Conductivity ($\mu\text{s}/\text{cm}^3$)	1025	426	326	685
a *	0.97	0.69	0.69	0.73

* Freeze & Cherry (1979) and Driscoll (1986) gave a conversion relationship with a as conversion factor between C (conductivity) and TDS as follows: $\text{TDS} = aC$.

Table 6.4 Total coliform distribution (per 100 ml) for boreholes, wells and springs (N)

	Boreholes N=54	Wells N=13	Springs N=10
0-10	34 (63%)	0	0
11-100	12 (22%)	0	6 (60%)
101-500	5 (9%)	6 (50%)	3 (30%)
501+	3 (6%)	6 (50%)	1 (10%)

TOTAL COLIFORM CONTAMINATION

The results for total coliform contamination of boreholes, wells and springs are shown in Table 6.4. Bacteria are present in all wells and springs samples. The wells gave a mean count of 604 with a standard deviation of 575. The springs had a mean count of 270 with standard deviation 521 (with one extreme value of 1800). The correlation between contamination and distance to the nearest pit latrine for individual wells and springs is weak and not significant.

The mean total coliform count for the boreholes on the sandstone aquifer was 58.7 counts per 100ml of sample while coral limestone gave a mean of 149.9 counts per 100ml of sample. Fig 6.2 and 6.3 give the relationship of pit-latrline distance and borehole contamination for sandstone and limestone aquifer respectively.

E.COLI CONTAMINATION

The E.Coli contamination for the different regions are shown in Table 6.5. Tiwi/Waa has the highest rate with a mean of 1.65 E.coli/100ml. Msambweni has a mean of 1.0 E.coli while Diani/Ukunda and Shimba Hills have 0.57 and 0.23 E.coli respectively.

Out of the 55 boreholes sampled in both sandstone and limestone aquifers only seven (13%) were contaminated with E.coli. Waa Secondary School had the highest count of 35 E.coli per 100ml of sample during the wet season but during the dry season the count went down to 4 E.coli/100ml sample. The remaining six boreholes contaminated had a mean count of 2 E.coli/100ml sample. Out of the 13 wells sampled nine (69%) were contaminated with E.Coli while the ten springs sampled showed contamination in only three (30%) of the springs. The highest count of E.Coli was observed in Mwayabo Bongwe with 50 E.Coli/ 100ml sample.

Table 6.5 E. coli contamination by location. (mean \pm s.d.)

	Diani/Ukunda (N=25)	Msambweni (N=10)	Shimba Hills (N=22)	Tiwi/Waa (N=20)
E.C.	0.57 \pm 0.4	1.0 \pm 0.94	0.2 \pm 0.59	1.65 \pm 0.9

Figure 6.2 Total coliforms in boreholes in sandstone area as a function of distance from the nearest pit latrine

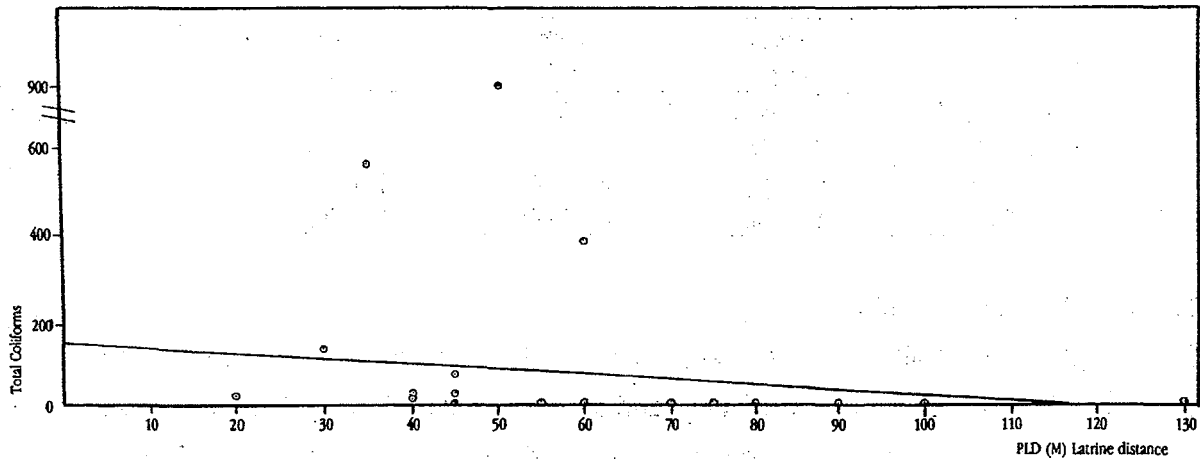
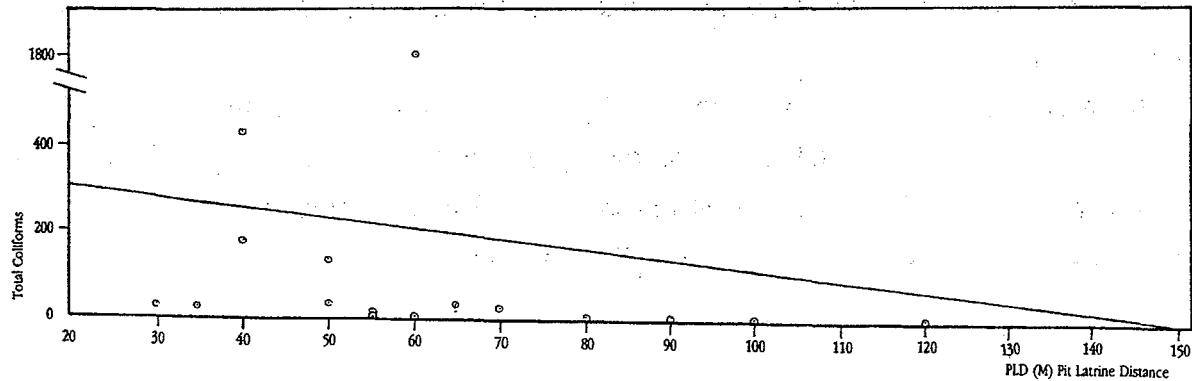

Figure 6.3 Total coliforms in boreholes in limestone area as a function of distance from the nearest pit latrine



Discussion

WET AND DRY SEASON VARIATIONS

Total coliform count showed a reduction in the dry season. This is because there is less rapid movement of water from pit-latrines to the boreholes in dry season.

INTER-REGIONAL WATER QUALITY

Waters in the different study locations seem to be a mixture of waters from different sources. Tiwi/Waa region has Ca-Mg/Cl-HCO₃ waters. Some borehole waters tasted salty and these waters had a substantially high Na:Cl ratio. In Diani-Ukunda the waters are also mainly calcium chloride and calcium bicarbonate. Exceptions were two wells that had a high Na:Cl ratio, probably due to sea water intrusion as both wells are about 1.5km from the sea shore. Majanga (1987) remarked that in the Diani area, the depth to the salt water level seems to increase from the coastline going inland Hence, Mwangi (1981) suggested

that the presence of a coral ridge parallel to the coastline provides a barrier to subsurface invasion by sea.

Shimba Hills waters are mainly calcium chloride with calcium bicarbonate. Kibwaga Chegeli shows a high Na-Cl content and this could be due to the effect of trapped connate salty water. This could also be the case in sandstone regions further inland where some areas also show high Na:Cl ratios. The chemical components of groundwater are a result of geographic factors such as climatic, hydrologic, biologic and chemical processes as well as geological ones which include mineralogical compositions, structure and texture of specific rock types (Maina, 1981). Todd (1959) showed that concentration of salts in water will depend upon the environment, movement and source of groundwater. In Msambweni the waters are mainly calcium carbonate and calcium chloride. There seems to be no indication of salt intrusion on the water sources sampled in this area. Anyango (1995) also noted less salt water intrusion in Msambweni compared to Tiwi/Diani, although a tongue of salt water occurred near the Mto Uvinje creek.

In the whole of the study area calcium is the most abundant ion (with mean 65.8 ppm and standard deviation of ± 49.3), followed by sodium with a mean of 32.9 and standard deviation of ± 23.8 . Chloride and fluoride have mean and standard deviations values of 108 ± 63 ppm, and 0.19 ± 0.11 ppm, respectively. The relatively high calcium content in the waters in this study reflect on the geology. The waters in the entire area are of mixed types, i.e. they are calcium bicarbonate or calcium chloride and it could also be a reflection of some climatic factors such as rainfall and temperatures. Driscoll (1986) noted that rainwater in coastal regions generally contains more chloride than it does further inland. This tends to leach into the surrounding rock formations and may be trapped as groundwater, hence accounting for the high content of the chloride in some boreholes and springs.

Potassium, fluorides, sulphates and pH constitute minor chemical constituents. Waters in the whole study area have a potassium content of 4.16 ppm. Sulphates have a mean of 10.6 ppm and magnesium 9.9ppm The waters have a mean pH of 6.63, and are essentially neutral. Potassium is not readily available in solution and this could be due to the K-bearing aquifer rocks which are resistant to weathering (Maina 1981).

As a whole, the waters in the study area have low concentrations of both the cations and anions and thus are suitable for domestic (drinking) and livestock use.

The ground water flow is generally either easterly or southerly. Diani has a mean TDS of 990 and Tiwi/Waa has 503, Msambweni has 436.1, while Shimba Hills has the least with 227.5 and this could be attributed to the underlying geology, distance from the ocean,

and the distance of flow from the recharge zone (Fig 6.1). There is a significant difference in the HCO_3 concentrations between Shimba Hills and the other regions

In Shimba Hills, the total coliform counts and *E.coli* are highly correlated ($r=0.68$). This could be due to faecal matter being the same source of the micro-organisms. Calcium and magnesium are also highly correlated ($r=0.72$). In Msambweni, calcium ions are highly related to bicarbonate ions ($r=0.62$). In Diani, total coliforms and *E.coli* count are highly correlated ($r=0.88$). Tiwi/Waa area shows a high correlation of sodium and chloride ($r=0.63$). TDS is correlated to sodium and chloride with $r=0.58$ and 0.87 respectively.

BACTERIOLOGICAL CONTAMINATION OF BOREHOLES

As indicated by Fig 6.2 and Fig 6.3, there is a general decrease in coliform counts with an increase in distance to the boreholes. From the mean values of counts in sandstone and limestone rocks it appears there is greater movement of bacteria in coral limestone than in sandstone aquifers. (Sandstone mean contamination = 58.7 coliforms/100ml; coral limestone mean contamination = 149.9 coliforms/100ml). The higher mean in corals could be due to channels within the formation, while the low mean in sandstone region could be due to greater compactness of the rock type. Nevertheless, some isolated boreholes have an abnormally high coliform count that can possibly be attributed to (i) spread of bacteria into the system when the pump is opened for maintenance and repair; and (ii) polluted waste water which is not properly drained, but instead leaks back into the borehole.

BACTERIOLOGICAL CONTAMINATION OF SPRINGS AND WELLS

No significant correlation existed between total coliform and pit latrine distance in both springs and wells. The results show that bacteria are present in all springs and wells samples. The contamination in springs could be more due to bad or poor back-filling, low yield, poor drainage, improperly submerged infiltration pipes, or infiltration of faecal matter.

The results show that drinking water from an open well can be hazardous to health. The contamination is greatly influenced by surface sources. The communities use buckets tied to ropes to fetch the water and this leads to contamination of the source. Small animals such as rats can fall into the water source, decay, and cause high contamination.

Conclusion and Recommendations

From the results and discussions it is concluded that the waters found in the sandy area are potable and generally useful for most domestic and livestock purposes. The chemistry of these groundwaters reflect the geological environment in which they flow. However,

improvement by climatic factors, especially rainfall and evaporation, together with the 'order of encounter' of these waters is also suggested. From the results of bacteriological analysis, it is concluded that the wells and springs are the most polluted with boreholes having the least contamination.

RECOMMENDATIONS TO IMPROVE WATER QUALITY FROM BOREHOLES

It is recommended that the following measures should be taken to reduce borehole water contamination:

- Communities with already polluted boreholes should be assisted in cleaning their sources with disinfectant preferably the method of chlorinating.
- Ensure that absolute hygienic conditions are observed when maintaining or repairing the pumps.
- Ensure that the area around the apron is kept dry and clean and that drainage is working well.
- Ensure that boreholes and latrines are separated by at least 120 metres in the sandstone region, and at least 150 meters in the limestone region. If possible, place the latrines on the down slope side.

RECOMMENDATIONS TO IMPROVE WATER QUALITY FROM PROTECTED SPRINGS

- Where a surface water source is found, fencing should be done at least a hundred metres upstream from the collection area to prevent cattle and other animals from contaminating the water.
- Put locks on the manholes to the collection chambers. This is to prevent people from contaminating the source by drawing water from the collection chamber.
- Submerge all infiltration pipes, in order to facilitate cleaning and prevent insects from nesting in the infiltration pipe.
- Improvement of drainage where this is poor in order to prevent waste water from leaking back into the collection chamber.
- Chlorination of springs where bacteria are found, should be carried out from time to time. However, it is not advisable to clean a spring that has no proper backfilling.

RECOMMENDATIONS TO IMPROVE WATER QUALITY FROM WELLS

- The KWAHO/SIDA project has met resistance when suggesting the covering of wells as the user community claims not to be affected by the water, they seem to have built some immunity. It would be of importance if the drilling teams, instead of drilling new boreholes, equip existing wells with handpumps. This is already in line with the

project policy. The user community would soon find out the benefits of covered sources and hopefully ask the project for assistance in covering their wells.

Abstract

Dissolution of rocks and infiltration from pit-latrines can cause pollution of groundwater. In this study, TDS, TSS, conductivity, COD, BOD, dissolved oxygen, calcium, magnesium, sodium, potassium, sulphates, chlorides, fluorides, coliform counts and E.coli as well as pH and temperature, were determined from selected boreholes, springs and wells in Kwale District, underlain by either sandstones or coral limestone. Water samples were taken from each of the water sources between September and November 1993 which represented the wet season (short rains) and between January and February 1994 which represented the dry season.

Data for two seasons, when compared, showed a slight increase in mean concentrations during the dry season for most parameters i.e. conductivity, TDS, Cl⁻, F⁻, Ca²⁺, sulphates with means 706.7, 487, 175, 0.3, 74, and 10.4 respectively.

The pH showed no change, with a mean of 6.63, while dissolved oxygen, COD, BOD, and coliform counts showed a decrease with means 0.64, 151, 1.61 and 160.5 respectively. Analysis using trilinear plots showed the major anions as chlorides and bicarbonates while the major cations are calcium and sodium.

The safe distance to locate a pit latrine from a water source in sandstone regions is recommended to be approximately 120m, while in limestone regions it should be at least 150m.

Acknowledgements

My special regards are due to Prof. C. O. Okidi for arranging the financial assistance during the research programme, the Government Chemist Department, Mombasa, for the help in chemical and microbiological analysis and the KWASP staff for their collaboration during the field work.

References

- Anyango O S (1995) *The chemistry and management of groundwater with respect to sea water intrusion in Kwale District*. M.Phil. thesis, Moi University, School of Environmental Studies.
- APHA (1985). *Standard methods for examination of water and waste water*. 16th ed. Washington: America Public Health Association.
- Chapman D (1992) *Water quality assessment*. London: Chapman and Hall.
- Driscoll F G (1986). *Groundwater: Water and wells*. 2nd ed. St. Paul (Minn.): Johnson.
- Freeze R A & Cherry J A (1979). *Groundwater*. Englewood Cliffs, N.Y.: Prentice-Hall.
- GESAMP (1988) Report of 18th session, Paris 11-15 April 1988. GESAMP Reports and studies No.33, Paris: UNESCO.
- Kwale District Development Plan, 1989-1993*. Nairobi: Ministry of Planning and National Development.
- Maina J W (1981). *Groundwater chemistry of the area to the immediate north of Nairobi conservation area*. M. Sc. thesis, Nairobi Un., Geology Dept.
- Majanga F I (1987). *Forward modelling for time-domain airborne. Electromagnetic data interpretation for groundwater exploration in South-coastal areas in Kenya*. M.Sc. Thesis. International Institute for Aerospace Survey and Earth Sciences, ITC Dept, Netherlands.
- Mwangi M (1981) *Resistivity survey for groundwater in Msambweni area*. M.Sc. thesis, University of Nairobi, Dept. of Geology.
- Mzuga J (1995) *The impact of geology and pit latrines on ground water quality of some boreholes, wells and springs in Kwale District*. M.Phil. thesis. Moi University, School of Environmental Studies.
- Todd D K (1959) *Groundwater Hydrology*. London: John Wiley.

MANGROVE CONSERVATION AND MANAGEMENT: A STRUCTURAL REGIME FOR THE KENYAN COASTLINE

E. M. OUKO & S. MANOHAR

Introduction

A total area of 52,980 ha of the Kenyan coastline is occupied by mangroves (Doute *et al*, 1981). The mangrove forest is a highly complex and productive ecosystem with many vital ecological and economic benefits. In Kenya, the ecosystem provides valuable products including high energy fuelwood; good and durable timber for building and boat construction; and suitable habitat for fisheries and other numerous organisms such as shrimps, prawns, oysters, snails, insects, birds, crabs and mammals. Mangrove forests, therefore, play a significant role in the socio-economic development of the coastal people of Kenya (Lusigi, 1982; Kokwaro, 1985). Human interference, accelerated by a growing population, is causing changes in the ecology, biological diversity, zonation and structure of the natural ecosystem (Kigomo, 1991; Rasowo 1992). It is important to note that each site has

its own habitat to support particular plant and animal species in their growth, development and distribution. In 1973, researchers began searching for the most meaningful ecosystem parameters to use in rapid characterisation of mangrove stands over wide geographic areas; the methods established and parameters selected needed to be simple, time/cost effective and universally applicable. A survey of some twenty-five mangrove stands in Florida, Puerto Rico and Costa Rica was undertaken to test the methods chosen (Pool *et al.*, 1977). The methods established in this study have come to be widely accepted as the standard for mangrove structural characterisation. In Kenya no comprehensive studies on mangrove structure, such as the watershed studies of Pool and his co-workers, have been undertaken. Therefore, this study attempts to establish the current structural status of selected mangrove forests along the Kenyan coastline and the available options for better management.

Materials and Methods

Shimoni and Gazi swamp are in the south coast in Kwale District and Mida Creek and Ngomeni are in the north coast in Malindi District (See Fig 8.1; p. 112). There was little variation in the climatic factors for the four study sites. The mean minimum and maximum temperatures ranged from is 29.0°C-33.8°C and 21.6°C-23.8°C respectively. The mean annual rainfall ranged from 1269-1059mm (Kenya Meteorological Department, 1984).

The methods for measuring structural attributes as summarised by Cintron & Novelli (1984) were used. A total of ten transects were laid after every 100m along the coastline and the total distance covered was therefore 1000m. A total of 100 quadrats per stand of size 10x5m was made. The attributes measured were density, stem forking, stem diameter, crown diameter, tree height, seedling count and stem basal area. Growth indices such as relative density, relative frequency, relative dominance, importance value index were calculated for all the species.

STRUCTURAL ATTRIBUTES MEASURED

Diameter

Only stems with a diameter at breast height (dbh) of 2.5cm or over were included in the count. The breast height was taken at the standard 1.3m. When the prop roots were above 1.3m, then the diameter was measured at just above the highest prop root.

Density

Density of a species = number of stems of a species/area

Forking

This refers to the branching of trees below the dbh mark of 1.3m. The individual branches are considered to be separate stems.

$$\text{Forking \%} = ((\text{No. of stems} - \text{No. of trees}) / \text{No. of trees}) \times 100$$

Mean Stand Diameter (M.S.D.)

This is the diameter of the stem of mean basal area which gives a quick and easy way of comparing the level of development of different stands.

$$\text{M.S.D.} = \sqrt{\text{BA} (12732.39) / n} \quad (1)$$

From the mean basal area (g), the diameter can be calculated. The MSD is a useful descriptive measure and is used for the comparison of stand development.

Relative density, dominance and frequency.

Relative density = (No. individuals of a species / Total no. individuals of all species) x 100.

Relative dominance = (Species basal area / Total stand basal area of all species) x 100.

Relative frequency = (Frequency of a species / Total frequencies of all species) x 100.

Importance Value Index (I.V.I.)

I.V.I. is an index of structural importance of a tree species within a stand of mixed species.

$$\text{I.V.I.} = \text{Relative density} + \text{relative dominance} + \text{relative frequency}$$

Complexity Index (C.I.)

This index enables easy comparison of overall development within the four stands.

$$\text{C.I.} = \text{No. of species} \times \text{stand density} \times \text{stand basal area} \times \text{stand height} \times 10^{-5}$$

Results ²**SHIMONI SWAMP**

The mean stand diameter and complexity index were 17.7cm and 20.17 respectively (Table 7.1). The density, forking percentage, dbh, crown diameter, height, seedling count, average stem basal area and total basal area of mangals were 1426, 11.93%, 13.9cm,

1. Where BA = stand basal area / ha; n = no. of trees / ha..

2. Detailed results are given in Ouko (1995)

Table 7.1 *Structural attributes of mangrove species at Shimoni swamp*

	Trees	Stems	Fork	Diameter	Crown Diameter	Height	Seedlings	Stem Basal Area	Total Species Basal A.
<i>A. marina</i>	95	158	66.32	20.1	5.3	9.5	868	530.0	83740
<i>R. mucronata</i>	668	674	0.90	10.4	2.9	6.5	6184	139.6	94090
<i>C. tagal</i>	42	47	11.90	19.1	4.1	10.5	300	351.8	16535
<i>B. gymnorrhiza</i>	153	205	33.99	20.1	3.7	8.1	1826	413.1	84686
<i>S. alba</i>	274	279	1.82	13.4	3.6	5.3	221	173.2	48323
<i>X. granatum</i>	42	63	50.00	14.2	4.3	6.3	58	388.8	24494
Stand Attributes	1274	1426	11.93	13.9	3.4	6.7	9457	246.8	351868
Mean Stand Diameter = 17.7cm / Complexity Index = 20.17									

Key: Trees = No. /ha Diameter = Av. (cm) Seedlings = No. /ha
 Stems = No. /ha Crown Diameter = Av. (m) Stem Basal Area in cm²
 Fork = Forking % Height = Av. Height (m) Total Species Basal Area in cm²

Table 7.2: *Importance Value Index and Rank of mangrove species studied at Shimoni area*

	D	R.D.	F	R.F.	Dom.	R. Dom.	I.V.I.	RANK
<i>A. marina</i>	158	11.1	32	14.5	83740	23.8	49.4	4
<i>R. mucronata</i>	674	47.2	80	36.4	94090	26.7	110.3	1
<i>C. tagal</i>	47	3.3	16	7.3	16555	4.7	15.3	6
<i>B. gymnorrhiza</i>	205	14.4	32	14.5	84685	24.1	53.0	2
<i>S. alba</i>	279	19.6	40	18.2	48323	13.7	51.5	3
<i>X. granatum</i>	63	4.4	20	9.1	24494	24.1	21.5	5

Key: D = Density/ha R.F. = Relative Frequency (%) R. Dom. = Relative Dominance (%)
 R.D. = Relative Density (%) Dom. = Dominance (cm²) I.V.I. = Importance Value Index
 F = Frequency %

Table 7.3 *Structural attributes of mangrove species at Gazi swamp*

	Trees	Stems	Fork	Diameter	Crown Diameter	Height	Seedlings	Stem Basal Area	Total Species Basal A.
<i>A. marina</i>	440	660	50.00	6.6	2.0	4.2	7736	86.7	57222
<i>R. mucronata</i>	500	516	3.20	6.2	1.6	4.3	2280	43.8	22601
<i>C. tagal</i>	560	664	18.57	3.9	1.5	2.8	9100	14.0	9296
<i>B. gymnorrhiza</i>	36	40	11.11	4.8	1.8	3.9	616	20.9	836
<i>S. alba</i>	40	48	20.00	8.7	2.0	4.2	20	73.3	518
<i>X. granatum</i>	44	64	45.45	9.3	3.2	6.6	40	116.6	7462
<i>L. racemosa</i>	128	204	59.38	4.9	2.1	3.9	404	21.0	4284
Stand Attributes	1748	2196	25.6	5.6	1.8	3.8	20196	46.5	102220
Mean Stand Diameter = 7.7cm / Complexity Index = 5.97									

Key: See Table 7.1

3.4m, 6.7m, 9457, 246.8cm² and 35.19m² respectively at Shimoni. Tree forking was limited and the leading species were *Avicennia marina* (Forsk.) Vierh. and *Xylocarpus granatum* (Koen.) at 66 per cent and 50 per cent respectively. The rest of the species were considerably less forked. *A.marina* and *Bruguiera gymnorrhiza* (Lam.) had the widest diameters of 20.1cm. *Rhizophora mucronata* (Lam.) had the lowest dbh of 10.4cm while the remaining three species were in between. *Ceriops tagal* (C.B.Rob.) was the tallest species at a height of 10.5m and *S.alba* the shortest at 5.3m. Although *Sonneratia alba* (Sm. Miliane) had the lowest average height, a few taller trees occurred especially in areas where it was interspersed with *R.mucronata*. The latter had the most prolific regeneration with a density of 6184 seedlings/ha. *B.gymnorrhiza* was second at 1826 seedlings/ha while the remaining species had less than 1000 seedlings/ha. *R.mucronata* and *B.gymnorrhiza* had the highest species basal areas of 9.41m² and 8.47m² respectively. Although *A.marina* had a density of only 158 stems/ha, the species had a large average stem diameter which resulted in a basal area of 8.37m².

In terms of I.V.I., the species were ranked in descending order as follows: *R.mucronata*, *B.gymnorrhiza*, *S.alba*, *A.marina*, *X. granatum* and *C.tagal* at 110.3, 53.0, 51.5, 49.4, 21.5 and 15.3 respectively (Table 7.2). *R.mucronata* was by far dominant in this swamp while *X.granatum* and *C.tagal* were very scarce.

GAZI SWAMP.

Gazi had a mean stand diameter and complexity index of 7.7cm and 5.97 respectively (Table 7.3). The density, forking percentage, dbh, crown diameter, height, seedling count, average stem basal area and total basal area of mangals were 2196, 25.60% 5.6cm, 1.8m, 3.8m, 20,196, 46.5cm² and 10.22m² respectively at Gazi. *C.tagal* had the highest density at 664 stems/ha and was closely followed by *A.marina* at 660 stems/ha. These were followed by *R.mucronata* and *Lumnitzera racemosa* (Gaertn.) at 516 and 204 stems/ha respectively. The rest of the species had densities of less than 70 stems/ha. The most forked species were *L.racemosa*, *A.marina* and *X.granatum* at 59.38 per cent, 50.00 per cent and 45.45 per cent respectively. The forking by these three species could be explained by their close proximity to the neighbouring human population and were therefore readily used as firewood. *X.granatum*, which has good coppicing abilities, was multi-stemmed whenever the main stem was cut.

The three species with the highest number of seedlings were *C.tagal*, *A.marina*, and *R.mucronata* at 9100, 7736 and 2280 seedlings/ha respectively. The species with the least seedlings were *X.granatum* and *S.alba* at 40 and 20 seedlings/ha respectively.

Table 7.4 Importance Value Index and Rank of mangrove species studied at Gazi swamp

	D	RD.	F	RF.	Dom.	R.Dom.	I.V.I.	RANK
<i>A. marina</i>	660	30.1	52	23.6	57222	54.4	108.1	1
<i>R. mucronata</i>	516	23.5	48	21.8	22601	21.5	66.8	2
<i>C. tagal</i>	664	30.2	56	25.5	9296	8.8	64.5	3
<i>B. gymnorrhiza</i>	40	1.8	20	9.1	836	0.8	11.7	6
<i>S. alba</i>	48	2.2	4	1.8	518	3.3	7.3	7
<i>X. granatum</i>	64	2.9	24	10.9	7462	7.1	20.9	4
<i>L. racemosa</i>	204	9.3	16	7.3	4284	4.1	20.7	5

Key: See Table 7.2

Table 7.5 Structural attributes of mangrove species at Mida Creek

	Trees	Stems	Fork	Diameter	Crown Diameter	Height	Seedlings	Stem Basal Area	Total Species Basal A.
<i>A. marina</i>	381	611	60.37	8.4	2.8	4.9	15859	111.9	68371
<i>R. mucronata</i>	437	456	4.35	8.9	2.2	5.4	996	112.8	51437
<i>C. tagal</i>	1337	1367	2.24	3.5	1.2	2.8	12063	11.6	15857
<i>B. gymnorrhiza</i>	37	63	70.27	15.8	4.0	6.8	52	242.1	15252
<i>S. alba</i>	33	37	12.12	17.6	3.7	6.3	70	267.2	9886
<i>X. granatum</i>	67	100	49.25	7.4	2.0	4.6	33	62.0	6200
<i>L. racemosa</i>	41	48	17.07	4.3	1.4	3.9	130	16.1	773
Stand Attributes	2333	2682	14.96	6.2	1.8	3.9	29203	62.6	167776
Mean Stand Diameter = 8.9 cm / Complexity Index = 12.29									

Key: See Table 7.1

Table 7.6 Importance Value Index and Rank of mangrove species studied at Mida Creek

	D	RD.	F	RF.	Dom.	R.Dom.	I.V.I.	RANK
<i>A. marina</i>	611	22.8	52	27.1	68371	40.8	90.7	1
<i>R. mucronata</i>	456	17.0	56	29.1	51437	30.6	76.7	3
<i>C. tagal</i>	1367	51.0	44	22.9	15857	9.4	83.3	2
<i>B. gymnorrhiza</i>	63	2.3	20	10.4	15252	9.1	21.8	4
<i>S. alba</i>	37	1.4	4	2.1	9886	5.9	9.4	6
<i>X. granatum</i>	100	3.7	8	4.2	6200	3.7	11.6	5
<i>L. racemosa</i>	48	1.8	8	4.2	773	0.5	6.5	7

Key: See Table 7.2

A.marina was the biggest contributor to the total stand basal area of 10.22m²/ha and indeed the species provided about half of the total basal area with 5.72m²/ha. *R.mucronata* species had the second highest basal area of 2.26m²/ha while the remaining species had basal areas of less than 1.00m²/ha.

In terms of I.V.I., the species were ranked in descending order as follows: *A.marina*, *R.mucronata*, *C.tagal*, *X.granatum*, *L.racemosa*, *B.gymnorrbiza* and *S.alba* at 108.1, 66.8, 64.5, 20.9, 20.7, 11.7 and 7.3 respectively (Table 7.4). Only *A.marina* and *R.mucronata* would be available for extraction commercially at a limited level. *C.tagal* could be useful for fuelwood and the production of small-sized poles. But otherwise, urgent measures should be taken to conserve the threatened Gazi mangrove ecosystem because the large community around the area depends on it for their various needs to a currently non-sustainable degree.

MIDA CREEK

Mida Creek had a mean stand diameter and complexity index of 8.9cm and 12.29 respectively (Table 7.5). The density, forking percentage, dbh, crown diameter, height, seedling count, average stem basal area and total basal area of mangals were 2682, 14.96%, 6.2cm, 1.8m, 3.9m, 29,203, 62.6cm² and 16.78m² respectively at Mida Creek. *C.tagal* had the greatest density of 1367 stems/ha, followed by *A.marina* with 611 stems/ha. The rest of the species had densities lower than 100 stems/ha. *B.gymnorrbiza* had the highest forking percentage of 70 per cent while *A.marina* was 60 per cent forked mainly due to cutting for firewood. *X.granatum* had a forking rate of 49 per cent and the rest were forked at below 20 per cent. *S.alba* and *B.gymnorrbiza* had the highest stem diameters of 17.6cm and 15.8cm respectively. *R.mucronata* and *A.marina* were third and fourth at 8.9cm and 8.4cm respectively. The rest of the species had stem diameters of less than 8.0cm

B.gymnorrbiza, *S.alba* and *R.mucronata* were the tallest species with averages of 6.8m, 6.3m and 5.4m respectively. The rest of the species had mean heights of less than 5.0m. *A.marina* and *C.tagal* had the highest regeneration rates at 15859 and 12063 seedlings/ha respectively. *R.mucronata* had 996 seedlings/ha while *L.racemosa* had 130 seedlings/ha and the remaining three species had less than 100 seedlings/ha.

In terms of I.V.I., the species were ranked in descending order as follows: *A.marina*, *C.tagal*, *R.mucronata*, *B.gymnorrbiza*, *X.granatum*, *S.alba* and *L.racemosa* at 90.7, 83.3, 76.7, 21.8, 11.6, 9.4 and 6.5 respectively (Table 7.6). *A.marina* and *R.mucronata* contributed about 70 per cent of the stand basal area at 6.84 and 5.14m² respectively (Table 7.5). The high basal areas of these two species offered opportunities for commercial exploitation. Similarly, *C.tagal* could be harvested for firewood.

Table 7.7 Structural attributes of mangrove species at Ngomeni swamp

	Trees	Stems	Fork	Diameter	Crown Diameter	Height	Seedlings	Stem Basal Area	Total Species Basal A.
<i>A. marina</i>	437	584	33.64	8.5	2.3	4.7	974	85.2	49757
<i>R. mucronata</i>	816	921	12.87	6.8	1.8	5.2	9316	49.6	45682
<i>C. tagal</i>	1263	1858	47.11	4.4	1.4	3.2	19605	18.5	34373
<i>B. gymnorrhiza</i>	126	216	71.43	6.0	2.0	3.8	1558	41.5	8964
<i>S. alba</i>	147	389	164.63	6.0	2.3	3.7	421	29.7	11553
<i>X. granatum</i>	5	16	220.00	8.5	2.2	6.0	10	71.1	1138
Stand Attributes	2794	3984	42.59	5.8	1.7	4.0	31884	38.0	151466
Mean Stand Diameter = 7.0 cm / Complexity Index = 14.49									

Key: See Table 7.1

NGOMENI SWAMP

Ngomeni swamp had a mean stand diameter and a complexity index of 7.0cm and of 14.49 respectively (Table 7.7). The density, forking percentage, dbh, crown diameter, height, seedling count, average stem basal area and total basal area of mangals were 3984, 42.59%, 5.8cm, 1.7m, 4.0m, 31,884, 38.0cm² and 15.15m² respectively at Ngomeni. *C.tagal* had the highest density of 1858 stems/ha which was more than double the second-placed *R.mucronata* at 921 stems/ha. *A.marina*, *S.alba*, *B.gymnorrhiza* and *X.granatum* followed with 584, 389, 216 and 16 stems/ha respectively. There was widespread cutting of *X.granatum* as signified by a forking rate of 220 per cent. The second most forked species was *S.alba* at 165 per cent and thirdly *B.gymnorrhiza* at 71 per cent and the rest of the species had forking rates of less than 50 per cent. *A.marina* and *X.granatum* had the highest average stem basal areas at 85.2cm² and 71.1cm² respectively. *R.mucronata*, *B.gymnorrhiza*, *S.alba* and *C.tagal* followed with 49.6, 41.5, 29.7 and 18.5cm² respectively. *X.granatum* was the tallest species on average at a height

Table 7.8 Importance Value Index and Rank of mangrove species at Ngomeni swamp

	D	RD.	F	R.F.	Dom.	R.Dom.	I.V.I	RANK
<i>A. marina</i>	584	14.7	48	21.8	49757	32.8	69.3	3
<i>R. mucronata</i>	921	23.1	64	29.1	45682	30.2	82.4	2
<i>C. tagal</i>	1858	46.6	72	32.7	34373	22.7	102.0	1
<i>B. gymnorrhiza</i>	216	5.4	24	10.9	8964	5.9	22.2	4
<i>S. alba</i>	389	9.8	8	3.7	11553	7.6	21.1	5
<i>X. granatum</i>	16	0.4	4	1.8	1138	0.8	3.0	6

Key: See Table 7.2

of 6.0m and was followed in second place by *R.mucronata* at 5.2m. *A.marina* was third at 4.7m while the remaining three species had mean heights of less than 4.0m. *C.tagal* had the highest regeneration at 19605 seedlings/ha and was followed by *R.mucronata*, *B.gymnorrhiza*, *A.marina*, *S.alba* and *X.granatum* at 9316, 1558, 974, 421 and 10 seedlings/ha respectively. The stand basal area was 15.15m². *A.marina*, *R.mucronata* and *C.tagal* together contributed 85.7 per cent of the total basal area.

In terms of I.V.I., the species were ranked in descending order as follows: *C.tagal*, *R.mucronata*, *A.marina*, *B.gymnorrhiza*, *S.alba* and *X.granatum* at 102.0, 82.4, 69.3, 22.2, 21.1 and 3.0 (Table 7.8). The high regeneration rate of 19605 seedlings/ha for *C.tagal* suggests that it is likely to remain prevalent in this swamp in the foreseeable future (Table 7.7). Commercial exploitation of the other species in Ngomeni will have to take into account the 'weedlike' nature of *C.tagal* because of expansion into open areas.

Only 16 stems and 10 seedlings/ha of *X.granatum* were found within the stand. In spite of the widespread cutting of *X.granatum*, it had the one but highest average basal area and was also the tallest on average at 6.0cm. These attributes indicate the possibility of this species, competing favourably with others if the right management strategies can be adopted.

Discussion

The six species found growing in all the four stands were *A.marina*, *C.tagal*, *R.mucronata*, *X.granatum*, *B.gymnorrhiza* and *S.alba*. *L.racemosa* was not observed in Shimoni and Ngomeni. *A.marina*, *C.tagal* and *R.mucronata* were the most dominant species in all the stands with one exception, *C.tagal*, in Shimoni. The seedling count was high for all the species except for *X.granatum* and *S.alba*. These two species depend on their coppicing ability for regeneration.

The mangrove stand at Shimoni had the highest complexity index of 20.17 while Ngomeni, Mida Creek and Gazi stands had complexity indices of 14.49, 12.29, 5.97 respectively. Shimoni swamp had the highest mean stand diameter of 17.7cm among the four stands. This value was much higher in comparison to the other three stands and indicated that Shimoni swamp had the most vibrant plant growth. The steep gradient leading to longer flooding periods within Shimoni swamp could have created better conditions for mangal growth. It is also likely that the widespread presence of corals hindered movement within the swamp and exploitation was therefore limited and enabled undisturbed plant growth.

Mida Creek had the second highest mean stand diameter of 8.9cm. This M.S.D. was greater than for Ngomeni which had the lowest value at 7.0cm. But the density of 2682 stems/ha in Mida Creek was only 67 per cent of the 3984 stems/ha found at Ngomeni. This, therefore, indicates greater plant development in Mida Creek than Ngomeni in spite of a lower complexity index. The scarcity of fully matured trees in Ngomeni is masked when complexity index is considered in isolation. This means that Ngomeni mangroves should be treated much more cautiously in terms of commercial exploitation in comparison to Mida Creek. It is notable that the stands with the most mature trees -Shimoni and Mida Creek- had the least forking at 11.93 per cent and 14.96 per cent respectively. The less developed stands of Gazi and Ngomeni had much higher forking rates of 25.60 per cent and 42.59 per cent respectively. This signifies the ability of man to influence mangrove development through exploitation.

Gazi had the lowest complexity index of the four stands. This coupled with a mean stand diameter of 7.7cm signified low mangrove development in this stand. The main reasons for the low development in Gazi swamp can be attributed to the severe effects of cutting and felling by man, and the wide and flat nature of Gazi swamp which results in many areas rarely receiving nutrient-rich fresh water.

CONSERVATION AND MANAGEMENT

R. mucronata is the most important species economically. It provides timber for commercial uses and its branches and prop roots are used by the local inhabitants for firewood. Sound management strategies will have to be devised so as to achieve sustainable levels of wood production. This species should be given the first priority in the management plan for commercial purposes. Currently, only felling plans for the different mangrove forests are in existence with no accompanying management plan for the ecosystem as a whole. This is likely to result in both widespread depletion of mangrove forests and the dilution of the complex ecosystem. There is a genuine danger of reaching a stage where serious shortages in mangrove timber and fuelwood will occur and irreparable damage effected on the ecosystem. *R. mucronata* is mainly cut for commercial purposes by harvesters licensed by the Forest Department. The local population in most cases only debranch and deprop the trees for firewood but in most cases complete felling is carried out by these licensed operators. The impact of the local populations on this species can be considered minimal. Closer monitoring of the licensees coupled with regeneration efforts should result in more sustainable utilisation.

A. marina was widespread at Gazi, Mida Creek and Ngomeni swamps, but was rare in Shimoni swamp. The species tends to grow close to the dryland and is only preceded as a pioneer species by *L. racemosa*. *A. marina* trees were commonly stunted due to widespread cutting by man. It was noticeable that the few untouched *A. marina* trees attained impressive sizes. The species was widely used as a source of firewood. The Forest Department should educate the local populations on the most appropriate management strategies for this species. For example, the people can utilise the side branches instead of cutting the main stem. It is also important to remember that people will utilise what is closest to them, and can therefore be obtained most conveniently, but as soon as it disappears they then resort to further removed and more valued species such as *R. mucronata*. The local population should also be educated on the need to preserve saplings during the harvesting of firewood and poles. Although *A. marina* seedling count was high, the number surviving to a viable state was much lower and, therefore, as a consequence the good coppicing abilities of *A. marina* should be taken into account in the management of the species.

Apart from Shimoni, the mainly young *C. tagal* trees were dominant in all the stands. This was purely due to their high stem densities. Indeed it seemed to be gradually expanding its borders and this is attributable to its better adaptation to the high salinity of open spaces as observed by Kairo (1992) at Mida Creek. This phenomena needs to be checked if the more commercially-valued species like *R. mucronata* and *B. gymnorhiza* are not to be severely suppressed. *C. tagal* is useful as a source of fuelwood and its expansion could be a considered an advantage in this respect. A management strategy to control *C. tagal* zonal expansion is necessary. It is notable that although this species was scarce in Shimoni, it was within this stand that it attained its most impressive growth indices. It had an average height of 10.5m and an average stem basal area of 351.8cm² and therefore indicating its potential given the right environmental factors.

L. racemosa is the pioneer species and, therefore, the most readily available for use by man. But its shrubby nature in most cases means that it is useful only as a source of fuelwood. Being the most accessible species means it suffers from widespread cutting. The good coppicing abilities of the species should be utilised for its propagation.

The sea-bordering *S. alba* had been widely cut in Gazi, Mida Creek and Ngomeni swamps in order to enable easier access to the ocean. It stands as the first line of defence against the erosive capabilities of ocean currents and the result has been increased erosion in areas such as Ngomeni swamp where it has been widely cut. Although the species coppices well, efforts towards establishing stands through artificial seedling regeneration

should be made if the production of well-rounded trees is the aim:

X.granatum was the least common species within the four swamps. It is useful as a source of timber with selective felling being the best method of harvesting. The species coppices well and this offers an alternative method for propagation. The problem with coppicing is that the stems are not as straight as the ones growing from seedlings. Therefore, one should consider the future uses of the species before settling on the appropriate method. A restoration strategy should be developed for this species especially since the usefulness of the fruit to humans reduces the chances of viable seedling regeneration.

B.gymnorhiza was best developed in Shimoni swamp. It is only in Shimoni that this species could safely be harvested commercially. In the other three stands it was found mostly in small patches. This species produces good timber, but its scarcity in most areas requires a careful management strategy in order to avoid over-exploitation.

Recommendations

- Selective logging should be the norm within mangrove forests in order to preserve as much of the complex ecosystem as possible. The local populations should be encouraged to cut only the side branches while harvesting firewood and avoid cutting the main stem.
- Studies on the growth rates of the trees should be carried out in order to devise proper felling plans. This should include studies on the regeneration and whether or not natural regeneration is adequate or should be supplemented by artificial regeneration. The research should include the monitoring of mangrove stands in order to monitor succession trends and their impacts on the management of the ecosystem. Specifically, the extent of *C.tagal* zonal expansion should be analysed. Furthermore, studies concentrating on the establishment of seedlings of all the species should be done especially in cases where timber for building and construction purposes is required. Three species — *X.granatum*, *L.racemosa* and *A.marina* — could be propagated by coppicing. For the remaining four species, standing seed trees should be a necessity in clear felled areas. The two most threatened species — *X.granatum* and *L.racemosa* — require special conservation efforts and might require regeneration through advanced methods such as biotechnology in order to save the threatened species and progeny.
- Alternative sources of timber and fuelwood might prove the best option for eliminating the threats facing mangrove ecosystems. The scarcity of land renders the establishment of new forest plantations unlikely and the community should be encouraged to adopt agroforestry systems instead. Agroforestry offers a viable alternative since it requires less

sacrifices in terms of land. Finding alternative sources of fuelwood and timber cannot be ignored in any mangrove conservation strategy and indeed all conservation efforts will inevitably have to confront this fact. It should therefore be a major priority in efforts towards mangrove conservation.

- A multi-disciplinary approach to the conservation and management of the mangrove ecosystem is necessary because it is a complex ecosystem which demands an integrated approach for sustainable management. The mandated institutions like the Forest Department, the Kenya Marine and Fisheries Research Institute, the Kenya Wildlife Society and all interested parties should pool their limited resources in order to provide greater hope for the conservation of this ecosystem.

Abstract

Structural attributes of mangrove forests were studied at Shimoni, Gazi, Mida Creek and Ngomeni swamps along the Kenyan coast. The study was conducted using the transect method and the diameters, densities, forking, tree height, crown diameters and regeneration of mangals were recorded. The mangrove stand at Shimoni had the highest complexity index of 20.17 while Ngomeni, Mida Creek and Gazi stands had complexity indices of 14.49, 12.29 and 5.97 respectively. Shimoni had the highest M.S.D. at 17.7cm. Both Mida Creek and Gazi with M.S.D. of 8.9cm and 7.7cm respectively were ranked higher than Ngomeni which stood at 7.0cm and indicated that Ngomeni harboured a young population. *R.mucronata*, *A.marina* and *C.tagal* had the highest Importance Value Index (I.V.I.) within the four stands except at Shimoni where *B.gymnorhiza* was ranked second to *R.mucronata*. The lowest ranked species were *S.alba*, *X.granatum* and *L.racemosa* with an exception only at Shimoni where *S.alba* was ranked third. *L.racemosa* was absent in Shimoni, Gazi and Ngomeni swamps. The results of this study indicate that there is an urgent need for a multi-disciplinary approach for the conservation and management of this complex mangrove ecosystem.

Acknowledgements

We thank the School of Environmental Studies, Moi University (MUSES) for the sponsorship that enabled the preparation of this paper. We also thank the workshop organisers, the MUSES Coast Environment Research Station and especially Prof. J. Hoorweg the co-ordinator.

References

- Cintron G & Novelli V S (1984). Methods for studying mangrove structure. In S C Snedaker & J G Snedaker (eds). *The mangrove ecosystem: Research methods*. UNESCO. pp.91-113.
- Doute R, Ochanda N & Epp H (1981). *A forest inventory of Kenya using remote sensing techniques*. KREMU Technical Report series. No.30. Kenya: Ministry of Environment and Natural Resources.
- Kairo J G (1992). *Some human induced stresses on mangrove Ecosystems of Kenya and their Social Implication*. Report prepared for the mangrove mapping team. Royal Dutch Embassy, for the Forest Department.
- Kenya Meteorological Department(1984). Climatological Statistics for Kenya. Kenya Meteorological Dept.

- Kigomo B N (1991). *Mangrove Ecosystem in Kenya: resources, management and conservation*. (Report No.5). Prepared for the ECE Group of the KFMP. Forest Department.
- Kokwaro J O (1985). The distribution and economic importance of the mangrove forests of Kenya. *Journal East African Natural History Society*, 75, 188, 1-10.
- Lusigi W J (1982). Socio-economic effects and constraints in forest management in Kenya. In E G Hallworth (ed.). *Socio-economic effects and constraints in tropical forest management*. John Wiley and Sons. pp. 123-130.
- Ouko E (1995) *A structural regime for mangrove conservation and management along the Kenyan coastline*. M.Phil. thesis. Moi University, School of Environmental Studies.
- Pool D J, Snedaker S C & Lugo A E (1977). Structure of mangrove forests in Florida, Puerto Rico, Mexico and Costa Rica. *Biotropica*, 9, 3, 195-212.
- Rasowo J (1992). Mariculture development in Kenya: alternatives to siting ponds in the mangrove ecosystem. *Hydrobiologia*, 247, 209-214.

8

MANGROVE FORESTS ALONG THE TIDAL FLATS AND LAGOONS OF NGOMENI, UNGWANA BAY

F. K. KAMAU

Introduction

Mangroves are the characteristic littoral plant formations of tropical and sub-tropical coastlines, found on the sheltered, muddy coasts, salt marshes and along brackish estuaries (Macnae, 1968; Chapman, 1977; Saenger *et al.*, 1983). The species found in these habitats are a diverse collection of trees and shrubs that have adapted to life in aquatic habitats that are under the influence of both freshwater and seawater (Ruwa, 1993). There are an estimated 68 tree species of mangrove of which 13 are found in East Africa (Snedaker & Snedaker, 1984). Kenya has nine species only (Graham 1929; Isaac & Isaac 1968; Kokwaro 1985).

Organisms which are associated with mangrove ecosystems include a wide variety of epiphytes, parasites and climbers among the flora, while the fauna are represented by

Figure 8.1 Mangrove distribution (area in ha.) along the Kenya coastline (Adapted from Ruwa, 1993)

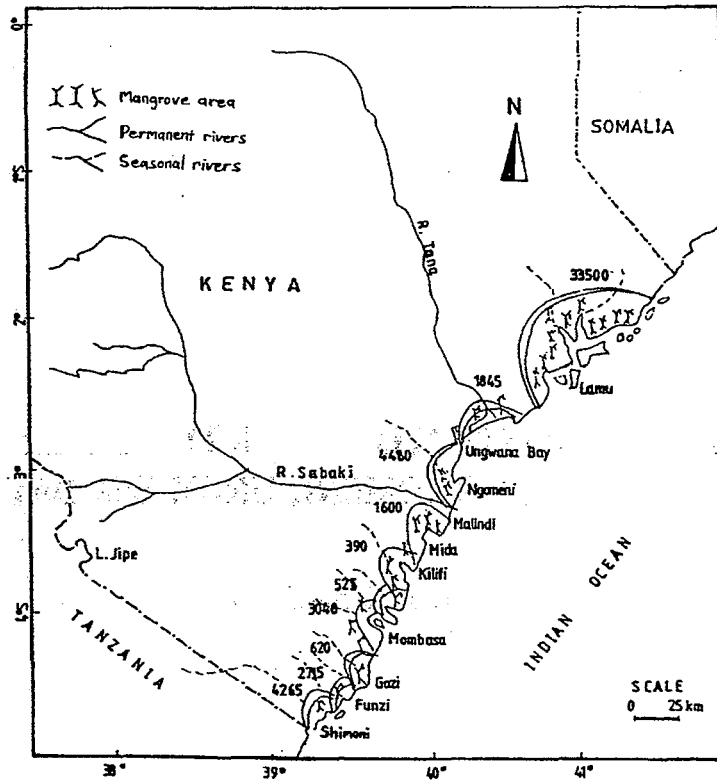
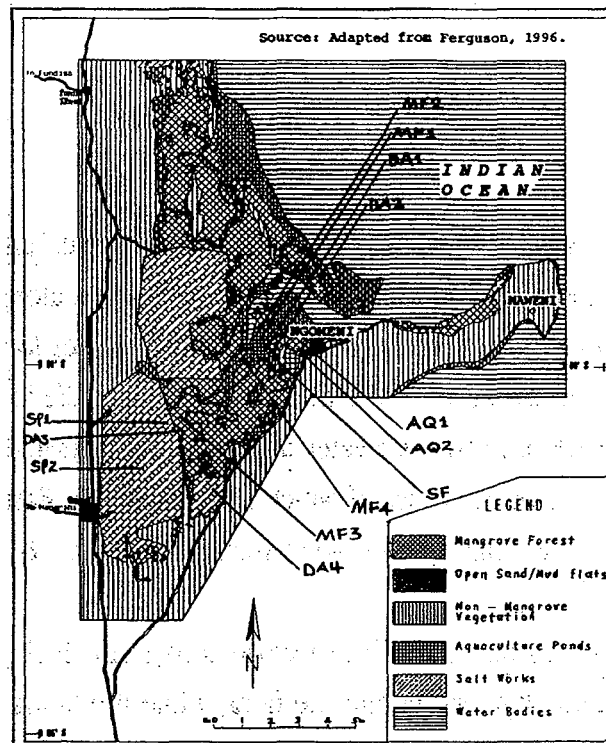

Figure 8.2 Location of study area and the sampling sites



large numbers of micro-organisms, crustaceans, molluscs, fishes and birds (Groombridge, 1992). Of the marine animals, crabs and molluscs live permanently in the forest, and prawns and fishes come in on the tide, to feed on the abundant nutrient provided by mangrove detritus from continuous litter fall (Macnae, 1968). The ecological values of these ecosystems revolve around their naturally high energy production capacity, their contributions to estuarine and marine productivity, and their various ecosystem functions, especially as nursery habitat to numerous fish and shellfish. Economically, the mangroves serve as a source of important products to coastal populations in the form of timber, firewood, charcoal, and food. In Kenya, the scattered patches of mangrove forests cover about 52,980 hectares of the total coastal area (Doute *et al.*, 1981) (Fig 8.1). The geographical distribution of the mangroves and their floral attributes are related to the shoreline configuration, the geomorphology and hydrology, especially the submarine ground-water discharges (SGD) which create brackish-water conditions required for successful development of their seeds (Ruwa 1990).

Utilisation and over-exploitation of these resources and conversion to other land and water uses, primarily fish ponds (aqua culture), infrastructure development, and salt pans, are drastically reducing the mangrove areas. In Kenya the last few decades have seen a drastic reduction of this natural resource (Christensen quoted in Hirsch & Mauser, 1992). Local communities harvest mangrove trees to cater for their fuelwood, timber, and poles. Community participation is needed in the management of mangrove resources through initiation of public awareness programmes on mangroves and allowing non-consumptive uses such as oyster farming and honey-collection. Exploitation of mangroves is leading to a decline of ecological diversity. At Ngomeni, mangroves are declining due to three main reasons; recent development of large scale salt production; rapid accretion processes leading to poor water circulation; and local development of mariculture. Replacement of mangrove forests with aqua culture and salt work developments may lead to changes in soil physical and chemical characteristics such that recolonisation from adjacent mangrove stands become impossible (Saenger *et al.*, 1983) even after the salt works have ceased operation. In order to sustainably manage these natural resources, ecological studies are needed to provide baseline information. The objectives of this study were to study macroflora and macrofauna of mangrove forests at Ngomeni; investigate the physical and chemical properties of soils; to compare the current status and extent of mangrove forests vis-à-vis that in the 1960s, and to formulate possible suggestions and recommendations for the sustainable management, conservation, and rehabilitation of the mangrove forests.

Study Area

The study was carried out along the tidal flats and lagoons fringing the barrier islands at Ngomeni, Ungwana Bay. Ungwana Bay is situated in Malindi District and lies between the latitudes 2°51'S and 3°02'S and longitudes 40°08'E and 40°15'E. A comparative study was undertaken to investigate different mangrove biotopes, namely relatively undisturbed, natural mangrove environments behind Simiti island, and those at Ngomeni where construction of salt ponds and aquaculture farms have led to extensive destruction of mangrove habitats (See Fig 8.1).

DESCRIPTION OF THE SAMPLING STATIONS

The study area was divided into six stations with some stations having sub-stations (Fig 8.2). Detailed descriptions of the stations are given below:

Station 1: This represented the aquaculture ponds (AQ) and had two sub-stations namely: Sub-station AQ1 (*Non-operational aquaculture pond*) The aquaculture pond which was non-operational during the whole period of the study exercise. It had not been stocked with prawns and the sluice gate remained open such that it was under the influence of tidal inundation during high tides. Sub-station AQ2 (*Operational aquaculture pond*): The pond was approximately 1.4 hectares and had been stocked with prawns and remained so during the whole sampling period.

Station 2: Station 2 was a transect line perpendicular to the creek and represented three different biotopes. Sub-station SF (*Sand Flat*), was a large area of bare, salty, "inversa" flats. It was devoid of any vegetation and dwarf *Avicennia marina* were scattered around the bare flats on the upper shore landward edge. It is 210 metres in width, and inundated only by the high tides of spring tide. Sub-stations DA1 and DA2 (*Degraded Area*) represented the area that initially had been cleared to pave way for the expansion of aquaculture activities but was never developed. Sub-station DA1 has a width of 105 metres, with very poor regeneration, less than five per cent coverage and mainly stunted *A. marina* interspersed with *Cerriops tagal*. Sub-station DA2 is 65 metres wide, almost a pure stand of *C. tagal* which had mostly been cut down, with good regeneration and cover of 30 per cent. It is bordered to the south by a small sand dune and to the north by a depression created during dyke construction. Sub-station MF1 (*Mud Flat*) is a dominantly tall *Rhizophora mucronata* forest within which were scattered *Bruguiera gymnorrhiza*, *Sonneratia alba* and tall *A. marina* extended to the creek edge. It has an estimated cover of 80 per cent, width of 60 metres and fringes to the creek. This is a strip of intact mangrove forest that was left during the aquaculture development.

Station 3 (MF2): A purely young stand of *A. marina* on an accreting mud-flat forming a sort of an island. Cover estimate is 85 per cent, and no signs of interference by man.

Station 4: This is a line transect cutting through a relatively undisturbed mangrove forest into salt-work ponds with three different biotopes. Sub-station MF3: 125 meters wide, characterised by huge *A. marina*, *R. mucronata*, *C. tagal* and with no distinct zonation. A tidal channel approximately two metres wide passed through this zone and continued to mangrove forest. Sub-station DA3: This area had been disturbed by clearance of mangrove vegetation during the construction of the saltworks' reservoir. Cover estimate of less than 5 per cent, 69 metres in width, and has stunted saplings of *A. marina*. To the north it borders a man-made channel created during the dyke construction. Sub-station SP1 and SP2 (Salt Pond): These represented the reservoir and evaporator pond for the salt works respectively.

Station 5 (DA4): Represented a reservoir of disbanded salt works. The salt works wound up in 1986 (Mjomba, 1995). It has a width of 247 metres and stunted *A. marina* getting established in areas that have puddles of standing water after the spring tide.

Station 6 (MF4): The mangrove forest at this station is approximately a transect of 157 metres, bordered by a creek channel on either sides. No clear zonation, and dominated by *B. gymnorhiza*, *R. mucronata* and *C. tagal*.

Materials and Methods

The study was carried out from November 1995 to March 1996 during the dry season period, and concentrated on mangrove forests under different anthropogenic pressures. Sampling was undertaken in all stations described earlier. A reconnaissance survey was conducted in November and all the stations clearly marked and sampling points established. In stations with forest cover, two to four plots of 10x10m were chosen depending on the width of the station. The description of the vegetation in terms of floristic composition, cover, circumference at breast height (CBH), number of stumps and status of regeneration was carried out. Mangrove tree species were identified according to Isaac & Isaac (1968). CBH was measured for trees with girth more than 12cm. Plants growing on the dykes were also collected even though they did not fall within the sampling station. The basal area was calculated from CBH values and expressed in square meters per hectare according to the procedure by Mall *et al.* (1982) and Chapman (1984).

SEDIMENT SAMPLING

In each station two PVC cores were taken and sectioned into 0-7.5cm (upper layer) and 7.5-15cm (lower layer). They were pooled together for textural analysis. Measurement of

the combined silt and clay content of the sediment was achieved by wet sieving sediment into sand fraction (particles greater than $63\mu\text{m}$) and a silt-clay (mud) fraction (particles less than $63\mu\text{m}$) (Buchanan, 1971). 30 grams of oven-dried sediment at 105°C was accurately weighed, desegregated by a pestle and mortar, then placed on to a $63\mu\text{m}$ sieve and water added, until no further material seemed to pass through the sieve. The sieve contents were dried at 105°C to represent the sand fraction. Its weight, subtracted from the original sample weight, gave the silt-clay (mud) fraction by difference. During sediment and macrofauna sampling, temperature was measured by an ordinary thermometer and salinity by a hand refractometer, by digging a hole up to 20cm and measuring these parameters from the seeping water. Due to logistical problems pH was only measured during the last month of the study. Separate cores were taken at each station once per month for five months. Two to three plastic cores were collected to a depth of 15cm at each sampling, stoppered on both sides and stored in an ice-box. The samples were transported to the laboratory on the same day and put in a freezer overnight. Initially sediment was sectioned at 5 cm intervals for familiarisation with the methods, pooling all the sections into a polythene bag. For the last three sampling dates, cores were sectioned at 3 cm intervals and placed in polythene bags to reduce spatial heterogeneity and treated as one sample. Nutrients mainly Ammonium-Nitrogen, Nitrate-Nitrogen, Phosphate and Sulphate were extracted by accurately weighing 10 grams (Sartorius R200d weighing balance) of sediment and extracting with 50ml of 1N KCl by shaking (Shaker-Julabo SW 200) for one hour (see Shaiful *et al.*, 1986; Laima, 1992; Caffrey & Kemp, 1992; and Rivera-Monroy *et al.*, 1995 on KCl extraction). The extracts were centrifuged for ten minutes (Centrifuge - ALC 4226) and decanted. Sub-samples were taken from each sediment depth interval for water content analysis by heating at 105°C for 24 hours (Grimshaw, 1989), and percentage organic matter by combusting at 600°C for 24 hours (Buchanan, 1971). KCl extracts were analysed for ammonium-nitrogen, phosphate-phosphorus by the method of Strickland & Parsons (1968); nitrate-nitrogen by a Technicon II Autoanalyser system; and Sulphates by the turbidimetric method. Shimadzu Double Beam (UV 150-02) Spectrophotometer was used.

MACROFAUNA SAMPLING

In each station a total of five samples were taken for epifauna and three samples for infauna during the low tide of the spring tide when the majority of macroinvertebrates are active. Epifauna samples were collected from within a 0.25m^2 square aluminium frame to 25cm depth at each sampling point. Animals dwelling on the soil surface were collected

from within the quadrat. Crabs were collected by digging up sediment from within the quadrat and removing all the animals visible to the naked eye (Sasekumar, 1974; Frith *et al.*, 1976). For infauna a 10x10cm square coring device was used and the cores transferred into plastic bottles. These samples were sieved through a 1 mm mesh sieve (Wells, 1983; Ismail, 1992) and the retained fraction was fixed with 4% formaline solution and stained with Rose Bengal. The retained fauna were identified to highest possible taxonomic level and counted using a binocular microscope.

MAPPING

Multi-temporal comparison of the status and extent of mangrove cover between 1960 and 1992 was also carried out. This was achieved by acquiring a digitized 1992 data base for Ngomeni area (Ferguson, 1996). The 1960 aerial photographs were acquired from the Survey of Kenya, interpreted and later, digitized. The digitization was executed in Arc-Info and these two data sets were over-layed and the changes in mangrove forest cover noted. These two sets of aerial photographs were the only ones available covering the study area.

DATA ANALYSIS

The species diversity was measured by calculating the number of species/taxa per station. The number of individuals of each species/taxa was totalled for every station and sub-station and then mean density values calculated. The mean was then multiplied by four for epifauna and by 100 for infauna so that the density value could be expressed as the number of individuals per meter squared. The means of all the parameters measured were subjected to ANOVA and statistical significance tested by the F-test and T-test at the 95 per cent confidence (Zar, 1984). Simple correlation between species diversity, physical parameters, and nutrient concentrations was also performed. Data from the various stations sampled were pooled together to represent the biotopes encountered.

Results ¹

FLORISTIC COMPOSITION

Of the 13 stations, only five stations had trees with a girth of more than 12cm, four of these had vegetation cover of more than 30 per cent while one had 28 per cent. On performing one-way analysis of variance (ANOVA) on the stations' mean densities, basal area, and percentage cover, the results showed significant differences ($F=4.556$, $F=5.98$, $F=19.21$; $p<.05$ respectively). The results were subjected to T-test to evaluate where the

¹ Detailed results are presented in Kamau (1996)

differences lie. Station MF4 had the greatest number of mangrove species (5); station MF2 had the greatest density; stations MF1 and MF3 had the largest basal area values; and station MF1 the highest percentage cover (Table 8.1 & 8.2). Station DA2 was on the area previously clear-felled to pave way for aquaculture and with good natural regeneration. Species found re-establishing themselves at this station are *A. marina* and *C. tagal* with equal densities of 330 stems/ha, and *R. mucronata* with 230 stems/ha. It had the lowest density, basal area, and percentage cover compared to the relatively undisturbed natural mangrove forest. Plants encountered but which did not fall within sampling stations, and were mainly growing on the dykes and fringes of high water mark include: *Cassipourea euryoides*, *Sporobolus vignatus*, *Trianthema triquetra*, *Hypertelis bowkeriana*, *Suaeda monoica*, *Sesuvium portulacastrum*, *Cissus rotundifolia*, *Sideroxylon inerme*, *Antbrocnemum indicum*, *Pluchea ovalis*, *Onella curviramea*, and *Pleurostelma cerneum*.

Table 8.1 Density by species (mean \pm s.d.)

	Density (no/ha)				
	MF1	MF2	MF3	MF4	DA2
<i>A. marina</i>	250 \pm 212	1567 \pm 252	170 \pm 150		330 \pm 230
<i>B. gymnorrhiza</i>				475 \pm 150	
<i>R. mucronata</i>	950 \pm 354		800 \pm 350	400 \pm 390	230 \pm 320
<i>C. tagal</i>			270 \pm 230	300 \pm 0.0	330 \pm 60
<i>X. granatum</i>				75 \pm 100	
<i>L. racemosa</i>				75 \pm 150	
<i>S. alba</i>	200 \pm 283	67 \pm 116			
Totals	1400 \pm 849	1634 \pm 368	1240 \pm 730	1325 \pm 790	890 \pm 610
% Cover	83 \pm 4	83 \pm 8	75 \pm 10	76 \pm 13	28 \pm 3

Legend: See Table 8.3

Table 8.2 Basal area by species

	Basal Area (m ² /ha)				
	MF1	MF2	MF3	MF4	DA2
<i>A. marina</i>	7.46	16.84	6.97		0.61
<i>B. gymnorrhiza</i>				12.34	
<i>R. mucronata</i>	24.05		15.16	5.45	0.44
<i>C. tagal</i>			3.05	1.31	0.7
<i>X. granatum</i>				0.19	
<i>L. racemosa</i>				0.28	
<i>S. alba</i>	1.23	0.15			
Totals	32.74	16.99	25.18	19.57	1.75

Legend: See Table 8.3

Table 8.3 Mean pooled epifauna, and infauna densities, and species diversity representing different biotopes (mean \pm sd)

	Density (no/m ²)		Species Diversity (spp/station)
	epifauna	infauna	
AQ	66.5 \pm 37.21	300 \pm 155	4.00 \pm 1.93
SF	96.0 \pm 13.27	0.0 \pm 0.0	2.80 \pm 0.45
DA	69.8 \pm 33.07	83.3 \pm 75.3	3.65 \pm 1.46
MF	90.0 \pm 22.74	567 \pm 250	6.70 \pm 2.03
SP	50.0 \pm 83.67	0.0 \pm 0.0	0.33 \pm 0.52

Legend:

AQ=aquaculture ponds; SF=sand flat; DA=degraded areas; MF=mangrove forest; SP=salt ponds

MACRO-INVERTEBRATE DENSITIES AND SPECIES DIVERSITY

One way ANOVA were performed on the data for species diversity, and the densities for both epifauna and infauna. The results showed significant differences between the various stations for both species diversity and infauna densities ($F=8.84$ and $F=11.47$ respectively, $p<.05$). There were no statistically significant differences between station densities for epifauna. Stations MF1, MF2, MF3, and MF4, had the greatest species diversity, and these are the stations that contained mangrove forest cover. Station DA2 was moderate in terms of mean epifauna density, mean infauna density and species diversity. It appears like a transition zone between degraded areas and the mangrove forest stations. Stations SF, DA1, MF3, and MF4 had the greatest mean epifauna densities, and stations MF1, MF2, and MF4 had the greatest mean infauna densities and there were no infauna species in the following stations; SF, DA3, SP1, SP2, and DA4. Stations with no vegetation cover equally had high mean epifauna densities but very low mean species diversity.

Table 8.3 gives a summary of mean pooled densities for infauna and epifauna, and species diversity for the various biotopes covered during this study. One way ANOVA were performed on the pooled data for species diversity, and the densities for both infauna and epifauna. There are no statistically significant differences between the different biotopes for epifauna. Sand-flats had the highest mean epifaunal densities followed by mangrove forest biotope. Aquaculture ponds and degraded areas followed with moderate densities, and saltworks ponds had the lowest. The results showed statistically significant differences between the various biotopes for both species diversity ($F=21.14$, $p<.05$) and infaunal densities ($F=17.36$, $p<.05$). Mangrove forest biotope had the highest mean species diversity and infauna densities, followed by aquaculture ponds. Degraded areas had moderate values with no infauna species collected in the sand flat and saltworks ponds. These last two stations also had the lowest mean species diversity.

PHYSICAL PARAMETERS IN THE STATIONS

Sediment composition was similar among sites with all being classified as muddy sand except stations MF3 and MF4 which were sandy mud. Temperature and salinity were subjected to one way ANOVA and the differences were statistically significant ($F=10.53$ and $F=9.11$ respectively, $p<.05$). Percentage organic matter and water content were subjected to two way ANOVA for comparisons among sites and sediment depths. Variations among the stations were significant for both organic matter and water content ($F=27.83$ and $F=23.08$ respectively, $p<.05$). There were no statistically significant differences with respect to depth profile of sediment. Mean temperatures were moderate within stations which had vegetation cover, mainly stations MF1, MF2, MF3, and MF4. The mean highest temperatures were in stations SF and SP1. Mean salinity levels were highest in stations SP1, SP2, and DA3, and lowest in AQ2, MF1, MF2, and MF4. pH values were highest in stations SP1, SP2, and AQ2 and lowest within mangrove forested stations mainly MF4, MF1, MF2, and also in station DA1. Percentage organic matter was highest in stations SP2 followed by stations under mangrove forest cover. Percentage water content was lowest in stations SF and DA4, and highest in stations MF1 and MF2.

Table 8.4 Mean pooled physical parameters in the different biotopes (mean \pm s.d)

	Texture			Temp°C	Salinity ‰	pH	% Organic Matter	% Water Content
	% sand	% clay	class*					
AQ	67.05	32.95	m.s.	29.7 \pm 0.8	41.94 \pm 3.57	7.9 \pm 0.7	9.25 \pm 1.35	40.69 \pm 4.27
SF	59.98	40.02	m.s.	30.8 \pm 1.1	66.09 \pm 13.96	7.3 \pm 0.6	5.14 \pm 1.49	21.13 \pm 1.61
DA	63.79	36.21	m.s.	30.0 \pm 1.0	54.65 \pm 13.32	6.7 \pm 0.8	8.76 \pm 3.82	34.08 \pm 7.08
MF	52.06	47.94	m.s.	28.1 \pm 1.1	41.09 \pm 3.67	6.4 \pm 0.6	13.45 \pm 2.41	43.71 \pm 5.87
SP	67.28	32.72	m.s.	31.0 \pm 0.9	99.42 \pm 33.77	9.5 \pm 0.1	12.12 \pm 6.63	40.60 \pm 4.36

Legend: See Table 8.3

* m.s. = muddy sand

PHYSICAL PARAMETERS FOR THE DIFFERENT BIOTOPES

Table 8.4 shows the mean physical parameters aggregated by different biotopes. All the biotopes had similar sediment composition being classified as muddy sand (where sand fraction $> 50\%$). Measured pH was highest in the salt ponds, moderate in aquaculture ponds and sand-flat, lowest in the mangrove forest and degraded areas biotopes. Temperature and salinity results were subjected to one way ANOVA and the differences are statisti-

cally significant ($F=28.54$ and $F=38.65$, $p<.05$) respectively. Percentage water content and organic matter are statistically significantly different on subjection to one way ANOVA ($F=7.79$ and $F=19.38$, $p<.05$ respectively). Temperature and salinity values were lowest in mangrove forest and in aquaculture ponds, moderate in degraded areas and sand-flat, and highest in saltworks ponds. Similarly water content (%) and organic matter (%) were highest in the mangrove forest and saltworks ponds biotopes, followed by aquaculture ponds and degraded areas, and lowest in the sand-flat.

AMMONIUM-NITROGEN, NITRATE-NITROGEN, PHOSPHATE AND SULPHATE BY STATION

Comparisons among stations and with respect to depth profile for edaphic parameters were carried out using two way ANOVA. There are statistically significant differences between stations, but none with respect to depth profile. Ammonium-nitrogen ($F=65.92$) and sulphate ($F=74.74$) were highly significantly different, whereas phosphate ($F=6.73$) and nitrate-nitrogen ($F=8.98$) (all at $p<.05$) were also significantly different. Ammonium-nitrogen was highest in station SP2 and SP1 and lowest in station SF. Nitrate-nitrogen was highest in DA4, DA2 and MF3 and lowest in stations SP1 and MF2. Mean phosphate levels were highest in SP2 and MF2, and lowest in station DA1. Mean sulphate concentration was highest in station SP2 and lowest in stations AQ2 and DA2.

AMMONIUM-NITROGEN, NITRATE-NITROGEN, PHOSPHATE AND SULPHATE BY BIOTOPE

Comparisons for nutrient status among the different biotopes was carried out using one way ANOVA. There are statistically significant differences between biotopes for the above edaphic factors. Ammonium-nitrogen ($F=63.07$) and sulphates ($F=12.76$) were highly significant, whereas phosphate ($F=7.12$) and nitrate-nitrogen ($F=3.53$) were also significant. Table 8.5 gives the mean concentrations for the above mentioned parameters. Ammonium-nitrogen concentration was highest in saltwork ponds, followed by mangrove forest and aquaculture ponds, and lowest in the sand-flat. Nitrate-nitrogen was highest in degraded areas and sand-flat, followed by mangrove forest biotope and lowest in aquaculture ponds and saltworks ponds. Phosphates were highest in saltworks ponds and mangrove forest, followed by sand-flat and degraded areas, and lowest in aquaculture pond. Sulphates were highest in saltworks ponds, followed by sand-flats, degraded areas and mangrove forest, and lowest in aquaculture ponds.

Table 8.5 Mean pooled concentrations for ammonium-nitrogen, nitrate-nitrogen, phosphate, and sulphates ($\mu\text{g/g}$) (mean \pm s.d)

	$\text{NH}_4\text{-N}$	$\text{NO}_3\text{-N}$	PO_4^{2-}	SO_4^{2-}
AQ	0.226 ± 0.086	0.023 ± 0.010	0.007 ± 0.002	1.022 ± 0.203
SF	0.066 ± 0.014	0.043 ± 0.013	0.010 ± 0.003	2.121 ± 0.449
DA	0.165 ± 0.030	0.047 ± 0.032	0.010 ± 0.005	1.638 ± 0.430
MF	0.247 ± 0.069	0.033 ± 0.018	0.016 ± 0.008	1.639 ± 0.362
SP	0.783 ± 0.249	0.022 ± 0.009	0.021 ± 0.012	3.174 ± 1.631

Legend: See Table 8.3

MANGROVE FOREST COVERAGE AND EXTENT

From the 1960 aerial photographs interpretation, the extent of mangrove forests at Ngomeni was 1,573.4ha, whereas that one of 1992 was 1,471ha. This indicates that approximately 102.4ha of mangrove forests representing six to seven per cent of forest cover has been clear-felled to pave way for salt extraction ponds and aquaculture developments. Logging to provide timber, poles, fuel-wood has also contributed to loss of mangrove forests.

Discussion

FLORISTIC COMPOSITION

There was marked anthropogenic interference of the mangrove vegetation especially in stations MF3 and MF4. Station DA2 had been cleared to pave way for expansion of aquaculture activities, but has been re-establishing itself naturally over time. If afforestation was carried out in the above station, especially with *A.marina* and *C.tagal* it would be successful, if the natural regrowth present is an accurate indicator of growth potential. Stations MF1 and MF2 had the highest densities, and least observed disturbance. In the Ngomeni mangrove forest ecosystem, the dominant species are *Avicennia marina* and *R.mucronata*. *B.gymnorhiza* was dominant in station MF4 only. *Avicennia marina* occurred mainly on the fringes of the high water mark, but large trees were to be found growing adjacent to the creeks. *S.alba* was found on the edges of creeks together with *R.mucronata*. Ouko (1996) in a study carried out in 1992 found *C.tagal* (1,263), *A.marina* (437) and *R.mucronata* (816) to have the highest tree densities at Ngomeni.

In the present study the mean tree densities for the same species were *R. mucronata* (716), *A. marina* (666), *C. tagal* (270). The differences can be explained due to the different methods of sampling and the location of sample sites, for instance Ouko (1996) used transect method whereas in this study sampling plots were demarcated.

The main forms of exploitation of Ngomeni mangroves is clearance to pave way for aquaculture and saltworks; and to provide poles for house construction and furniture, fencing, wood for smoking fish, and scaffolding. The most exploited species by the local communities are *R. mucronata*, *B. gymnorrhiza*, and *A. marina*. In areas along the dykes and in the fringes of high water, more salt-tolerant species replace mangrove species. This could be attributed to the fact that mangrove tree species will find difficulties in getting established in areas that are mostly dry and have high salinity levels. However, very stunted and scattered *A. marina*, could be encountered growing near such areas. Distribution of the mangroves was closely linked with salinity levels, with *A. marina* having the widest distribution attributed to its salt extraction capabilities. It could be found growing close to creeks as a pioneer species and in the fringes of high waters along the dykes of saltworks and aquaculture ponds. These areas are characterised by high salinity levels. *R. mucronata* and *S. alba* were only observed in areas with low salinity levels inundated by high waters regularly. *C. tagal*, *Xylocarpus granatum*, *B. gymnorrhiza* and *Lumnitzera racemosa* were found to be performing well in areas with moderate salinity levels, especially in station MF4.

Speybroeck (1992) argues that when considering mangrove re-afforestation projects along the Kenya coast, seedlings should be planted under fixed conditions and in their specific distribution zones. This study suggests that possible strategies may differ from those of Speybroeck (1992) in that in station DA2 which had initially been clear-felled, *A. marina*, *C. tagal* and *R. mucronata* were found growing together. The contributing factors to apparent zonation could be scarcity of propagules, salinity levels, and probably nutrient status. Afforestation trials at Gazi (Kairo, 1995) succeeded and it was concluded that afforestation of mangrove areas does not have to follow any species specific distribution zones.

In terms of productivity, presented in this study as basal area per hectare, stations MF1 and MF3 had the greatest value, and these two are comparatively old stands as compared to stations MF4 and MF2. MF2 is a relatively young stand of *A. marina*, getting established on an accreting mud-flat. Station MF4 had lower basal area/hectare as a result of harvesting of *R. mucronata* and *B. gymnorrhiza* by the local communities. Station DA2 which is reestablishing itself naturally could form a good site to initiate reforestation programmes.

Figure 8.3 Variations of macro-invertebrate species diversity with respect to four physical parameters: (a) temperature; (b) salinity; (c) % organic matter, and (d) % water

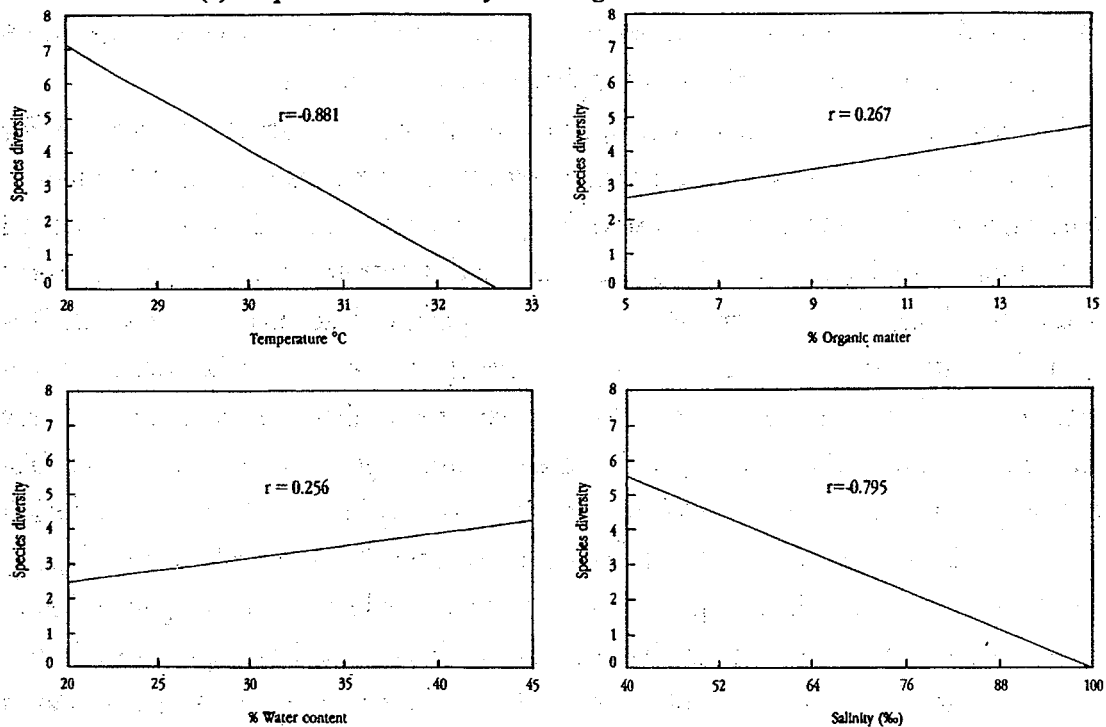

MACRO-INVERTEBRATE DENSITIES AND SPECIES DIVERSITY

The results presented in Table 8.3 clearly demonstrate a steady change in macro-invertebrate distribution in the various biotopes of Ngomeni mangrove ecosystem. Stations with mangrove vegetation had the highest mean species diversity and infauna densities; stations AQ2, SF, DA3, SP1, SP2 and DA4 had the lowest mean species diversity. The few species of epifauna (mainly *Uca* species) that occurred in stations SF, DA3 and DA4 were present in large numbers giving some of the highest mean epifauna densities. Mean infauna densities were highest in stations MF1, MF2 and MF4. These are stations with mangrove vegetation, and are inundated by high waters every day. The present study revealed that high macro-invertebrate species diversity was associated with moderate salinity and temperature, high percentages of organic matter and water content. This could be attributed to the presence of mangrove trees which moderate micro-habitats, and the mangrove litter fall which contributes to the detritus food chain. Stations which initially had mangrove vegetation, but were cleared during saltworks and aquaculture developments (DA1 and DA3), had lower mean species diversity, and it can be concluded that clearance of mangrove vegetation leads to decline in faunal diversity.

Frith (1980) showed that grain composition, and organic and moisture content are of primary importance to macro-invertebrates, especially crabs, other factors being absence

or presence of mangrove vegetation, temperature and salinity. Another important factor for fauna distribution and abundance is sediment (Edward & Ayyakkannu, 1992), and in this study, stations with the greatest species diversity had sandy mud texture. There was no in-fauna present in stations DA3, SF, SP1, SP2, DA4. This could be attributed to high salinity and temperatures, texture, and low organic matter. Stations DA3 and SF are inundated only by high spring tides every fortnight. During neap tide these areas get desiccated leading to low water content due to evaporation, high temperatures leading to salinity-induced stress. In stations SP1 and SP2 the limiting factor is the high salinity levels, and in Station DA4, high temperatures, high salinity levels and low organic matter content could be the contributing factors. This trend is clearly indicated in Fig 8.3. In this study, total in-faunal densities ranged between 0 to 733 individuals/m². Schrijvers (1991) found a range between 265 to 6025 individuals/m² for macrobenthos at Gazi and concludes that Gazi is richer in macrobenthos densities than other similar areas. The dense canopy of forest provides protection against desiccation and may offer cover against predators. Odum and Heald (1975) showed that the majority of animals found within a Florida mangrove swamp consume organic detritus in one form or another, and could explain the relationship between species diversity and organic matter content.

Frith *et al.* (1976) found at Ao Nam Bor that the majority of herbivorous and omnivorous animals found within the mangrove biotope feed on organic detritus, and scavenging animals such as isopods, amphipods, crabs and gastropod species feed on all grades of mangrove organic detritus, and animal detritus. It is noteworthy that the diversity and abundance of the macro-invertebrates was notably higher within the mangrove forest biotope than in degraded areas with sparse or no vegetation, or the aquaculture ponds and the saltworks ponds. This suggests a high degree of inter-relationships and adaptation to a mangrove forest environment. Ruwa (1993) in a study carried out in 1986 at Ngomeni mangrove ecosystem found the following epifauna which favourably compares with the ones observed in this study: *Sesarma guttatum*, *Terebralia palustris*, *Macrophthalmus dupressus*, *Uca urvillei*, *Uca lactea*, and *Uca inversa*. *Eurycarcinus natalensis* was not observed. Additional species collected included *Uca vocans*, *Scylla serrata*, *Anadara spp.* and a gastropod.

PHYSICAL PARAMETERS AND NUTRIENT STATUS

The limitation of the present study is that pH, which is a very important parameter, was measured only during the last month of the study and as such cannot be correlated with the other measured parameters. Both the salt work ponds SP1 and SP2 had high pH val-

ues. Aquaculture ponds (AQ1 and AQ2) similarly had high pH values. In the non-operational aquaculture pond the pH would have been expected to be low but was actually 8.5. Acid sulphate in pond soil can be recognised by very low pH values (below 4) according to Hechanova (1983). The discrepancy could be attributed to the fact that the sluice gates remain open and the pond is inundated all the times, thus there is no time for drying and oxidation of pyrite. Secondly, it could be assumed that the soil is non-acid sulphate. pH values were low in the mangrove forest probably due to presence of humic acids arising from detritus decomposition.

Salinity levels were highest in the salt-work ponds as compared to the other biotopes. The salt-work ponds are permanently inundated and this combined with high salinity levels could explain the low species diversity recorded. Station SF and DA4 had high salinity levels, and lack of vegetation and low species diversity could be attributed to this. In station DA4, which is a disbanded saltworks pond, the dykes are still intact and this impedes water movement into the area during high tide (spring tide). If the dykes could be demolished this area could be reforested with *A. marina* which has high salinity tolerance levels. The mangrove forest biotope had moderate salinity levels which favour both vegetation growth and macro-invertebrate abundance. Organic matter content was highest in the mangrove biotope (Table 8.4) which also had the highest water content levels. Saltworks ponds had high values for both organic matter and water content. The high organic matter content can be attributed to accumulation of organic detritus and lack of mineralization since very few organisms can thrive under high salinity levels prevailing in these ponds. Sand-flat and degraded areas biotopes had the lowest organic matter and water content. Low organic matter content could be attributed to lack of vegetation and thus no litter fall. Low water content is attributed to high evaporation rates on the exposed surfaces due to lack of vegetation.

In this study phosphate had the lowest concentration and sulphates the highest in terms of nutrients. Concentration values for ammonium-nitrogen and nitrate-nitrogen are similar to those measured by Shaiful *et al.* (1986). The mean pooled concentration data between the various biotopes were subjected to T-test. For ammonium-nitrogen there are statistically significant differences between the salt-work ponds and the rest of biotopes. There are also statistically significant differences between mangrove forest biotope, sand-flat, and the degraded areas. For nitrate-nitrogen there are statistically significant differences between degraded areas, and aquaculture pond, mangrove forest, and salt-ponds. Sand-flat and degraded areas showed no statistical differences, attributed to good aeration and thus no hindrance to nitrification process and also little or no nutrient demand for

vegetation growth. Phosphate concentration showed no statistically significant differences between the salt-work ponds and mangrove forest. However, there are statistically significant differences between salt-work ponds (highest concentration), and aquaculture ponds, sand-flat, and degraded area biotopes. Sulphate concentration showed statistically significant differences between salt-work ponds (highest concentration) and all other biotopes. There are also statistical significant differences between aquaculture pond (lowest concentration) and all the other biotopes.

The relatively low concentration of inorganic nitrogen in the mangrove soils could be due to low rate of mineralization otherwise exported during tidal inundations as observed in salt-marshes (Axelrad *et al.*, 1974 quoted in Shaiful *et al.*, 1986). Stations AQ2, SP1 and SP2 which were permanently inundated with water had the highest ammonium concentration and corresponding low nitrate levels. This could be attributed to slow rate of mineralisation of organic matter which stops at ammonium stage due to lack of oxygen (Table 8.5). This was followed by stations with mangrove vegetation (MF1, MF2, MF3, MF4), and low levels of nitrate concentration and occurrence of ammonium as the major form of inorganic nitrogen could be due to absence of nitrification or nitrate is being denitrified. Station DA4 had the highest nitrate concentration, which could be explained as due to well aerated sediment or run-off from adjacent agricultural activities, and grazing of cattle on the dykes. Sand flat was the poorest in terms of nutrient status. Phosphate concentration was highest in stations SP2 and MF2. These two stations present a salt work pond and the mangrove forest station on the accreting mud-flat. These high levels of phosphates concentration can be explained to what Agate (1988) attributed to increase in available phosphorus due to water logging leading to solubilization of ferric phosphates, release of occluded phosphates, and hydrolysis of ferric and aluminium phosphate. The other stations generally had low phosphate concentrations. According to Boto (1988) chemical affinity of phosphate with iron and manganese oxides/sesquioxides is strong and can result in strong chemical binding of phosphate to the clay particles containing these oxides. The combined process of phosphate immobilisation via precipitation of salts of Ca, Fe, Al and strong adsorption on clays result in significant net removal of phosphorus. In tropical mangroves it has been estimated that up to 88 per cent of the forest P-pool is retained within the forest (Agate, 1988).

In this study there were no statistically significant differences with respect to depth profile. Similar observations were made by Laima (1992), and Rivera-Monroy *et al.* (1995). This could be attributed to bioturbating activities of the macro-invertebrates. Simple correlation analysis between physical parameters (organic matter, water content, tempera-

ture, and salinity), nutrient concentration, and the macro-invertebrate species diversity was performed for each station. Each station had a unique combination of parameters showing high correlation and it would be hard to exhaustively discuss all of them. A positive correlation implies that an increase in one factor leads to a corresponding increase in the other factor being correlated. The converse holds for a negative correlation. In station AQ1 there was a strong positive correlation between species diversity and organic matter ($r = .92$), and with temperature ($r = .94$). Optimal increase in temperature would enhance microbial activity, enhancing detritus breakdown. Availability of organic matter in fine form provides food for the macro-invertebrates, increasing their abundance.

In the eight quadrants in station AQ2 there was a strong negative correlation between species diversity and temperature ($r = 1.00$), organic matter ($r = -.96$), and with nitrate-nitrogen ($r = -.96$). AQ2 is an operational aquaculture pond that was permanently inundated. In such a case abundance of macro-invertebrate would depend on phytoplanktonic growth and the manure added. An increase in temperature would enhance this productivity thereby affecting macro-invertebrate abundance favourably. While species diversity increases with increase in temperature, nitrate concentration decreases due to the denitrification process necessitated by anaerobic conditions. In station DA1 negative correlation existed between temperature and species diversity ($r = -.87$), and ammonium-nitrogen ($r = -.87$). The negative correlation could be attributed to desiccation resulting from high temperatures leading to decrease in species diversity. In station DA3 a strong correlation existed between ammonium-nitrogen and phosphate ($r = .97$) which could be attributed to improved aeration since this station is located further landwards and only inundated by the high spring tides. Improved aeration enhances microbial activity leading to mineralisation of detritus, and thus corresponding increase in nutrients. Secondly it is near to agricultural settlements and there could be run-off of nutrients into this station.

Mean pooled phosphorus concentration was high in both mangrove forest and saltworks ponds. These two biotopes are mostly waterlogged and under reducing conditions. The increase in availability of phosphorus under waterlogged conditions has been attributed to reductant solubilization of ferric phosphates, release of occluded phosphates by reduction of hydrated ferric oxide coatings and hydrolysis of ferric and aluminium phosphates (Mohanty & Dash, 1982). In station MF4 there was a strong positive correlation between species diversity and ammonium-nitrogen ($r = .96$). Henriksen & Kemp (1988) note that there is high potential nitrification activity found in the lining of permanent infauna burrows, and these rates are consistently higher than corresponding nitrification activity of the sediment surface due to improved aeration of sediment and ammonium excretion. This

coupled with the processing of leaves by crabs and snails may be an important factor in the cycling of carbon and nutrients in the mangrove ecosystem. Sulphate concentration was highest in the saltworks ponds. Under reducing conditions, trace metals mainly aluminium, iron, and manganese are more soluble leading to release of sulphate.

Reduction of inorganic sulphur compounds into sulphides greatly depends on increasing water level, addition of organic material, and rise in temperature (Agate, 1988). It has been suggested that mangrove sediments operate as biogeochemical sinks for heavy metals, mainly due to the high concentrations of organic matter and sulphides under permanently reducing conditions. Silva *et al.* (1990) showed that mangrove trees transfer oxygen from aerial roots and may release it through the roots into the anoxic sediments which oxidise Fe^{2+} and Mn^{2+} to insoluble $\text{Fe}(\text{OH})_3$ and MnO_2 . Oxygen diffusing from live roots increases redox condition in the surrounding sediment thereby suppressing sulphate reduction in mangrove forest. Biotopes with high sulphate concentration, high organic matter, iron, and aerobic environment alternated with limited aeration are prone to acid sulphate soil formation. Reforestation of saltworks would have to contend with such a problem, and for it to succeed proper soil management must be ensured. Similarly clearing of mangroves especially ones under *Rhizophora* and bordering the creek where the above conditions exist would probably give rise to acid sulphate formation.

CHANGES IN MANGROVE FOREST COVER

The limitation of the mapping aspect of mangrove forest in this study is that only two sets of aerial photographs were employed, that is one from 1960 and one from 1992. As such it does not reflect the gradual changes that have occurred over time. Secondly, changes in mangrove cover may have occurred between 1992 and now. The reason for choosing these two periods was that 1960 aerial photographs of the study area were available from the Survey of Kenya, and a digitized database of 1992 was available from KWS. Overlay of 1960 and 1992 maps gave the changes that have occurred within the mangrove forest between these two dates. Areas that had mangrove forests in 1960 and have been replaced by other developments include, saltwork expansion (243.3 ha), aquaculture (10.9 ha), open sand/mud flats (79.8 ha), and non-mangrove vegetation (103.3 ha). Mangrove forests have also expanded into areas that in 1960 were under open/mud flats (173.9 ha) and non-mangrove vegetation (102.4). This reflects a net loss of mangrove forests of 102.4 hectares, approximately seven per cent, in Ngomeni area.

Conclusions

Information for conservation, sustainable utilisation, and management purposes is mostly generated from ecological studies, because such studies are directly involved with the study of the structure and function of nature and the consequences of human use of resources. From this study the following conclusions can be drawn. Mangrove forest resources are being over-exploited, and the hectarage has been decreasing over time. This is attributed to aquaculture and saltworks expansion, and exploitation to provide timber, poles, and firewood. This replacement of the ecosystem has led to decline in forestry productivity, decline in macroinvertebrate species diversity, and has led to changes in soil's physical and chemical properties. To safeguard further loss of mangrove forests and their services, undertaking an inventory of the current status of mangroves and draft a management plan is needed.

RECOMMENDATIONS FOR SUSTAINABLE MANAGEMENT, CONSERVATION, AND REHABILITATION OF MANGROVE FORESTS ALONG THE KENYAN COAST

One strategy for rational use and management of Kenya's mangrove forests could be based on the following guidelines. Mangrove forests should be utilised on the principle of sustained yield and multiple use basis, and conversion of mangroves to aquaculture ponds and saltworks should proceed with extreme caution and must be carefully evaluated both ecologically and socio-economically. Areas devoid of mangrove cover should be rehabilitated in all areas along the Kenyan coastline; education, scientific, and socio-economic research on the mangrove ecosystem is needed and the establishment of a National Mangrove Research Institute would be a strong step toward providing this. Effective legislation on exploitation of mangroves with a provision for EIA. Lastly, continued research on mangrove ecosystem and areas being rehabilitated to provide concrete data that can be used for further planning and management. Application of GIS by employing satellite imagery and aerial photographs should be enhanced for monitoring mangrove forest areas.

Abstract

The study was carried out from November 1995 to March 1996 during the dry season period, and concentrated on mangrove forest under different anthropogenic pressures. A total of six stations with 13 sub-stations were demarcated representing five biotopes; mangrove forest, degraded mangrove areas, saltwork ponds, sandflat, and aquaculture ponds. Macroflora and macrofauna composition, soil characteristics, extent and status of mangrove forests at Ngomeni are presented and discussed. Floristic composition in terms of density, cover, and basal area (m^2/ha), and macroinvertebrate in terms of epifauna and infauna densities, and species diversity are discussed. Soil physical parameters namely pH, salinity, temperature, texture, organic matter, water content; and

nutrient status mainly ammonium-nitrogen, nitrate-nitrogen, phosphates, and sulphates were monitored during the study period. A total of seven mangrove tree species were collected. There are no statistically significant differences between the various biotopes for epifauna; differences in infauna densities and species diversity in different biotopes were statistically significant. Mangrove forest biotope had the highest infaunal densities, while no infauna were recorded for sandflat and the saltworks ponds. Species diversity (no. of species or taxa / station) was highest in the mangrove forest and lowest in the saltworks ponds. Sediment texture was mainly muddy sand (>50% sand) in all the biotopes, temperature and salinity were moderate in mangrove forest biotope (28.1°C and 41.1‰, respectively) and extreme in the sandflat (30.8°C and 66.1‰ respectively) and saltworks ponds (31°C and 99.4‰ respectively). The pH was highest in saltworks and aquaculture ponds (9.5 and 7.9 respectively) and lowest in the mangrove forest (6.4). Percentage organic matter and water content were highest in mangrove forests (13.45% and 43.7%) and saltwork ponds (12.12% and 40.6% respectively) and lowest in sandflats (5.14% and 21.1% respectively). There are statistically significant differences in the nutrient status between the biotopes. Ammonium-nitrogen ranged between 0.066 µg/g of wet sediment in the sandflat to 0.783 in saltworks ponds; nitrate-nitrogen ranged between 0.022 in saltworks to 0.047 in degraded areas; phosphates ranged between 0.007 in aquaculture ponds to 0.021 in saltworks ponds; and sulphate ranged between 1.022 in aquaculture ponds to 3.174 in saltworks ponds.

Biotopes with moderate temperature and salinity levels, and high levels of organic matter and water content had greater species diversity. Simple correlation analysis was also performed. A great deal of mangrove forest cover has been lost to aquaculture and saltworks developments, on comparison between earlier (1960s) and recent (1992) aerial photographs. Destruction of mangroves has led to decline in both forestry output and macroinvertebrate diversity, and changes in soil physical and chemical parameters. Rehabilitation conservation, and sustainable utilisation of the mangrove forest resources is highly recommended.

Acknowledgements

I would like to thank both my supervisors, Prof M. P. Tole and Dr. Els Martens for their guidance and support from the initiation of this research project to ultimate completion. Special thanks to UNEP through SES, Moi University, and AAS for their financial support. Special regards to scientists, friends, and my fellow colleagues for their moral support.

References

- Agate A D (1988). The sulphur and iron cycle. In A D Agate, C V Subramanian & R Vannucci (eds), *Mangrove microbiology: Role of micro-organisms in nutrient cycling of mangrove soils and waters*. UNDP/ UNESCO regional project research and its application to the management of the mangroves of Asia and Pacific (RAS/ 86 / 120). pp. 101-107.
- Boto K G (1988). The phosphorus cycle. In A D Agate, C V Subramanian & R Vannucci (eds), *Mangrove microbiology: Role of micro-organisms in nutrient cycling of mangrove soils and waters*. UNDP/ UNESCO regional project research and its application to the management of the mangroves of Asia and Pacific (RAS/ 86 / 120). pp. 85-97.
- Buchanan J B (1971). Measurement of the physical and chemical environment. In N A Holme & A D McIntyre (eds), *Methods for the study of marine benthos*. IBP Handbook No. 16. Oxford: Blackwell.
- Caffrey J C & Kemp W M (1992). Influence of the submerged plant *Potamogeton perfoliatus*, on nitrogen cycling in estuarine sediments. *Limnol. Oceanogr.*, 37 (7), 1483 - 1495.
- Chapman VJ ed. (1977). *Wet coastal ecosystems*. Amsterdam: Elsevier Science Publishers.
- Chapman VJ (1984). Botanical surveys in mangrove communities. In S C Snedaker & J G Snedaker (eds) *The mangrove ecosystem: research methods*. UNESCO Bungay, U K: Richard Clay.

- Doute R, Ochanda N & Epp H (1981). *Forest cover mapping using remote sensing techniques*. Nairobi: Kenya Rangeland Ecological Monitoring Unit. Technical report No. 30.
- Edward J K P & Ayyakkannu R (1992). Benthic macrofauna of Coolean estuary, Southeast coast of India. *Phuket Marine Biological Centre Research Bulletin*, 57, 67 - 76.
- Ferguson W (1996). *Landscape ecology of mangrove forests in Kenya*. Nairobi: Kenya Wildlife Service.
- Frith D W, Tantanasiwong R & Bhatia O (1976). Zonation and abundance of macrofauna on mangrove shore, Phuket Island. *Research Bulletin Phuket Marine Biological Centre*, 10, 1 - 37.
- Frith D W (1980). Ecological and population studies of Fiddler crabs (Ocypodidae, Genus Uca) on a mangrove shore of Phuket Island, Western Peninsular Thailand. *Crustaceana*, 39 (2), 157-184.
- Graham (1929). Mangrove swamps of Kenya. *Journal East Africa Natural History Society*, 36, 157 - 164.
- Grimshaw H M (1989). Analysis of soils. In S W Allen (ed.) *Chemical analysis of ecological materials*. Oxford: Blackwell.
- Groombridge B (1992). *Global biodiversity: Status of the Earth's living resources*. London: Chapman and Hall.
- Hechanova R G (1983). Problems of pond construction and maintenance on cat clay soils. In UNDP / FAO, *Inland aquaculture engineering* - Lectures presented at the ADCP inter - regional training course in Inland aquaculture engineering 6th June - 3rd September, Thailand pp 267 - 274.
- Henriksen K & Kemp W M (1988). Nitrification in estuarine and coastal marine sediments. In T H Blackburn & J Sorensen (eds), *Nitrogen cycling in coastal marine environments*. SCOPE, New York: John Wiley. pp 208 - 270.
- Hirsch D & Mauser R (1992). *The economic values of mangroves: Mida creek and Funzi Bay*. Amsterdam: University of Amsterdam.
- Isaac W E & Isaac F M (1968). Marine botany of Kenya Coast (3) General account of the environment, flora and vegetation. *Journal East Africa National History Society*, 27 (1), 7 - 28.
- Ismail N S (1992). Macrobenthic invertebrates near sewer outlets in Dubai creek, Arabian Gulf. *Marine Pollution Bulletin*, 24 (2), 77 - 81.
- Kairo J G (1995). *Artificial regeneration and sustained yield management of mangrove forests at Gazi Bay, Kenya*. M.Sc. thesis, University of Nairobi.
- Kamau F K (1996). *Ecological studies of mangrove forests along the tidal flats and lagoons, Ngomeni, Ungwana Bay*. M.Phil. thesis, Moi University, School of Environmental Studies.
- Kokwaro J O (1985). The distribution and economic importance of the mangrove forests in Kenya. *Journal East African Natural History Society*, 75, 1 - 2.
- Laima M J C (1992). Extraction and seasonal variation of NH_4^+ pools in different types of Coastal marine sediments. *Marine Ecological Progress Series*, 72, 75 - 84.
- Macnae W (1968). A general account of the fauna and flora of mangrove swamps and forests in the Indo-West Pacific region. *Advance Marine Biology*, 66, 73 - 270.
- Mall L P, Billore S K & Amritphale D (1982). Certain ecological observations on mangroves of the Andaman Islands. *Tropical Ecology*, 23 (2), 34 - 42.
- Mjomba (1995). personal communication.
- Mohanty S K & Dash R N (1982). The chemistry of waterlogged soils In B Gopal *et al.* (eds) *Wetlands: Ecology and management*. New Delhi: International Scientific Publications.
- Odum W E & Heald E J (1975). The detritus based food web of an estuarine mangrove community. In L E Cronin (ed.) *Estuarine Research*. New York: Academic Press. pp 265 - 286.
- Ouko E M (1996). *A structural regime for mangrove conservation and management along the Kenyan coastline*. M.Phil. thesis, Moi University, School of Environmental Studies.
- Rivera - Monroy V H, Day J W, Twilley R R, Harrera F V & Coronado-Molina C (1995). Flux of nitrogen and sediment in a Fringe mangrove forest in Terminos Lagoon, Mexico. *Estuarine, Coastal and Shelf Science*, 40, 139 - 160.

- Ruwa R K (1990). The effects of habitat complexities created by mangroves on macrofaunal composition in brackish intertidal zones at the Kenyan Coast. *Discovery and Innovation*, 2 (1), 49 - 55.
- Ruwa R K (1993). Disturbances in mangrove vegetation and their possible influence on other biota. *SAREC documentation: Conference Reports 1993*. 1, 104 - 126. Stockholm, Sweden.
- Saenger E J, Hegeri E J, Davies J D S (1983). *Global status of mangrove ecosystems*. Commission on Ecology papers No.3. IUCN, Netherlands.
- Sasekumar A (1974). Distribution of macrofauna on a Malayan mangrove shore. *Journal Animal Ecology*, 43, 51 - 69.
- Schrijvers J (1991). *Ecological study of the benthos of the mangroves and surrounding beaches at Gazi Bay, Kenya*. M.Sc. thesis. Ghent: University of Ghent.
- Shaiful A A A, Abdul-Manan O M, Ramli M R & Veerasomy R (1986) Ammonification and nitrification in wet mangrove soils. *Malaysian Journal Science*, 8, 47 - 56.
- Silva C A R, Lacerda L D & Rezende C E (1990). Metals reservoir in a red mangrove forest. *Biotropica*, 22 (4), 339-345.
- Snedaker S C & Snedaker J G (1984). *The mangrove ecosystem: Research methods*. UNESCO, Bungay: Richard Clay.
- Speybroeck D van (1992). Regeneration strategy of mangroves along the Kenyan coast: A first approach. In V Jaccarini & E Martens (eds) The ecology of mangrove and related ecosystems. *Hydrobiologia*, 247, 243 - 251.
- Strickland J D H & Parsons T R (1968). A practical book of seawater analysis. *Fisheries Research Bd. Canada Ottawa Bull.* pp.167-311.
- Wells F E (1983). An analysis of marine invertebrate distributions in a mangrove swamp in north Western Australia. *Bulletin for Marine Science*, 33 (3), 736 - 744.
- Zar J H (1984). *Biostatistical analysis*. New York: Prentice Hall.

EAST COAST AKALAT: HABITAT SELECTION AND DISTRIBUTION IN ARABUKO-SOKOKE FOREST

P.M. MATIKU, L. BENNUN & J.F.E. ODANGA

Introduction

The East Coast Akalat (*Sheppardia gunningi sokokensis* Van Someren 1921) is regarded as a globally threatened species (Collar *et al.*, 1994). The occurrence of this member of the Turdidae is restricted to isolated forest sites on the East African Coast. Three subspecies of the species are known: the *nominate* form in the south of Mozambique; *bensoni* from Malawi, and finally - the focus of this study - *sokokensis* from several forests in Tanzania and Kenya (Keith, 1992). This subspecies has been found in Kenya in forests of the Tana River Delta, the Arabuko-Sokoke Forest, Shimba Hills, a small forest patch in Shimoni, in Tanzania in lowland parts of the East Usambara Mountains, the Pugu Hills, the Litipo Forest Reserves, the Rondo plateau and even in the Jozani Forest at Zanzibar.

Figure 9.1 Arabuko-Sokoke Forest: Vegetation types, plot distribution and Akalat survey routes

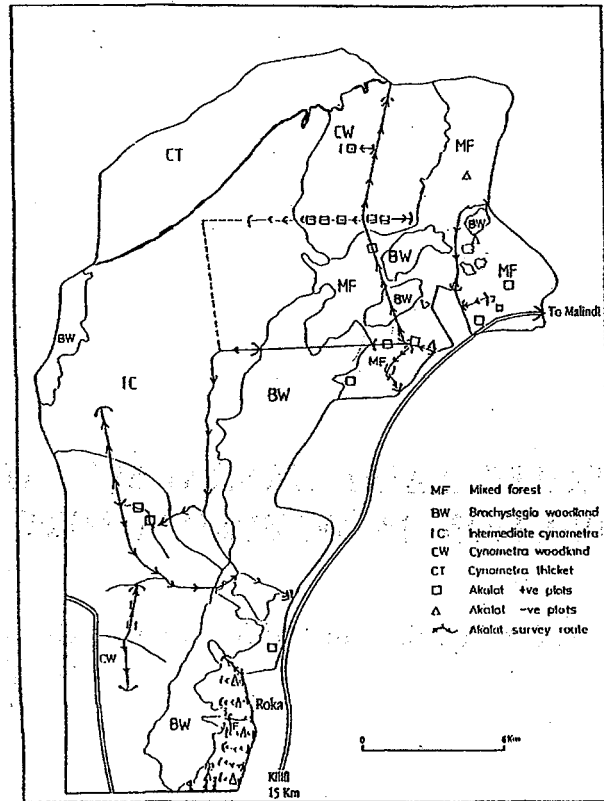
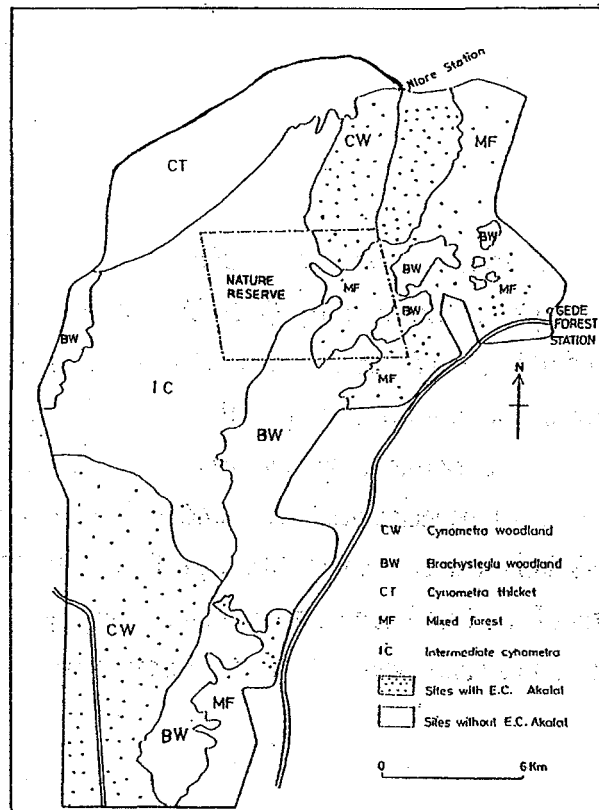

Figure 9.2 Distribution of the East Coast Akalat in Arabuko-Sokoke Forest



The Akalat has been known to inhabit the lower forest strata and has been seen to fly-catch insects from a perch or to search for food from the ground. In coastal forests like Arabuko-Sokoke it seemed to prefer moister sites (Britton & Zimmerman, 1979).

Arabuko-Sokoke Forest is the major remnant of the forests that once covered much of the East African Coast (Collar & Stuart, 1988). This forest contains an extraordinary diversity of rare bird species. These include: Sokoke Scops Owl (*Otus irenae*), Spotted Ground Thrush (*Zoothera guttata*), Sokoke Pipit (*Anthus sokokensis*), Amani Sunbird (*Anthreptes reichenowi*), Clarke's Weaver (*Ploceus golandi*), and finally the focus of this study: the East Coast Akalat (*Sheppardia gunningi sokokensis*).

The aim of this study was to investigate habitat selection and distribution of the East Coast Akalat. The specific objectives were to:

- Map out the distribution of the East Coast Akalat in Arabuko-Sokoke Forest;
- Determine the East Coast Akalat's population size and density in Arabuko-Sokoke;
- Investigate some habitat factors that might influence the distribution of the East Coast Akalat in Arabuko-Sokoke;
- Provide recommendations for the conservation of the East Coast Akalat in its habitats.

Besides their scientific value the results should provide information for the forest management to maintain or improve the status of Arabuko-Sokoke forest and the East Coast Akalat throughout its range. To understand why this bird is patchily distributed throughout its range and to formulate effective scientifically based management decisions, site-based research was crucial.

Study Area

Arabuko-Sokoke Forest covers an area of some 400km² and lies at 3°20'S and 39°55'E with rainfall of 600mm to 1100mm annually and annual mean minimum temperatures vary between 26°C and 30°C. The forest topography is characterised by flat, coastal plain. There are three soil types in the forest: dark red, infertile magarini sand-soils, forming a shelf 60m above sea level, and a variety of loose and compact sands and coral rag bordering the coastal belt (Kelsey & Langton, 1984).

The reserve, by nature of its diverse soil types, encompasses three main forest habitats: namely the dense, almost impenetrable Mixed forest, the structurally similar but lower canopied *Cynometra-Manilkara* Forest, and the more open *Brachystegia* woodland (Fig 9.1). A detailed description of the forest vegetation was given by Britton & Zimmerman (1979) and Kelsey & Langton (1984).

Table 9.1 Akalat population size and density by forest type

	REACTION DISTANCE	POPULATION SIZE (pairs)	DENSITY (pairs/km ²)
CYNOMETRA WOODLAND	Minimum (50m)	18127	183
	Mean (66m)	13732	138
	Maximum (105m)	8632	87
MIXED FOREST	Minimum (60m)	1520	35
	Mean (104m)	877	20
	Maximum (170m)	537	12

Table 9.2 T-test between habitat parameters from Cynometra woodland and Mixed forest Akalat present whole plots

	MIXED FOREST ¹	CYNOMETRA WOODLAND ¹	t-stat.
Litter depth (mm)	11.16 ± 3.33	9.87 ± 6.03	0.56
Litter cover (%)	62.45 ± 8.44	56.28 ± 5.37	2.02
Herb cover (%)	2.37 ± 3.21	2.6 ± 2.30	0.33
No. of fallen trees	1.13 ± 0.47	1.56 ± 1.04	1.16
No. of cut stems	2.13 ± 1.32	3.63 ± 1.73	2.06
No. of dead logs	2.95 ± 1.77	9.72 ± 2.79	9.89*
No. of mossy logs	0.75 ± 0.51	3.70 ± 1.54	6.67*
No. of stems < 6cm dbh	836 ± 90	1195 ± 228	3.55*
No. of stems > 6cm dbh	14.61 ± 4.19	12.83 ± 2.71	1.04
% veg. cover at 0-2 m	32.47 ± 13.11	41.61 ± 9.64	2.56*
% veg. cover at 3-8 m	24.93 ± 10.02	22.94 ± 7.53	0.93
% veg. cover at >9 m	11.46 ± 6.18	4.14 ± 2.04	3.55*
% canopy density	57.43 ± 7.88	62.92 ± 5.68	1.70
Ant density (no/10cm ²)	7.35 ± 4.94	3.02 ± 1.57	3.51*
No. of ant columns	0.011 ± 0.03	0.52 ± 0.32	5.23*

1. mean ± sd

* p < .05

Materials and Methods

PRELIMINARY SURVEY

In the first month of the study (October 1995) a pilot study of Arabuko-Sokoke's *Cynometra*, *Brachystegia* woodland and Mixed forest habitats was carried out. Areas with East Coast Akalat were noted.

DISTRIBUTION

To determine the overall distribution of the Akalat point counts along straight or almost straight transects, trails or old roads, were conducted (Fig 9.1). All singing East Coast Akalat were counted and localised as exactly as possible. Every 500m on road transects and every 100m, or if necessary every 50m, on trails a tape recording was played of the song or call of the species and the reactions of the bird recorded (singing, warning or approaching). Bird registrations were recorded and extrapolated to produce an Akalat distribution map (Fig 9.2).

To determine Akalat evenness of distribution, foot surveys were conducted in the Mixed and *Cynometra* habitats. In each habitat, two transects were followed. The bird's call was played after every 100m. The presence or absence and numbers of the East Coast Akalat seen or heard were recorded against a cumulative distance. The total transect length was 7100m and 6600m in *Cynometra* and Mixed forest respectively. All counts were conducted before 10.00 hours or after 17.00 hours. At these times the Akalat were observed to be most actively singing and their response was almost assured.

HABITAT PREFERENCE

Data on habitat preference were obtained following a plot based-design as used by Wiens (1989). In the Mixed forest, Akalat present¹ plots (200x200m each), were selected by numbering all the sites (recorded from earlier survey) containing East Coast Akalat. Numbered papers were put in a box. Eleven sites (plots) were randomly selected by picking numbered papers from the box without replacement. All the sites where no Akalat was registered during preliminary survey (except sites next to Akalat positive plots) were numbered. Ten Akalat absent plots (200x200m each) were randomly selected by picking numbered papers without replacement.

The *Cynometra* woodland occurs in two forest blocks one in the southern (66km²) and the other in the northern part (33km²) of Arabuko-Sokoke. Two transects (old logging

¹ Also referred to as A.Present and A.absent sites respectively

Table 9.3 Comparison of habitat parameters from 11, 200 x 200m-plots each from *Cynometra* woodland and Mixed forest (mean \pm s.d.).

	MIXED FOREST (-) ¹ (a)	CYNOMETRA WOODLAND (+) ¹ (b)	MIXED FOREST (+) ¹ (c)	t-stat (a) vs (b) (a) vs (c)
Litter depth (mm)	6.84 \pm 2.88	9.87 \pm 6.03	11.23 \pm 3.53	1.46 5.62*
% litter cover	45.87 \pm 12.54	56.28 \pm 5.37	62.57 \pm 8.89	2.23* 3.89*
% herb cover	4.13 \pm 3.75	2.60 \pm 2.30	2.57 \pm 3.32	0.87 0.97
No. of fallen trees	2.00 \pm 0.75	1.56 \pm 1.04	1.16 \pm 0.49	1.47 3.19*
No. of cut stems	8.78 \pm 6.02	3.63 \pm 1.73	2.16 \pm 1.39	3.18* 3.44*
No. dead logs	1.55 \pm 0.73	9.72 \pm 2.79	2.89 \pm 1.86	9.35* 2.90*
No. of mossy logs	0.18 \pm 0.23	3.70 \pm 1.54	0.70 \pm 0.50	7.79* 3.92*
No. of stems < 6 cm dbh	532 \pm 161	1195 \pm 228	850 \pm 295	14.45* 3.21*
No. of stems > 6 cm dbh	7.84 \pm 2.53	12.83 \pm 2.71	14.34 \pm 4.30	6.48* 3.52*
% Veg. cover at 2m	25.10 \pm 17.16	41.61 \pm 9.64	33.21 \pm 13.57	3.15* 1.38
% Veg. cover at 3-8 m	17.93 \pm 14.60	22.94 \pm 7.53	11.51 \pm 6.51	1.08 0.65
% Veg. cover at >9 m	10.02 \pm 8.52	4.14 \pm 2.04	11.51 \pm 6.51	2.17* 0.65
% Canopy density	48.09 \pm 9.23	62.92 \pm 5.68	58.21 \pm 7.84	6.76* 2.23*
Ant density (No./10cm ²)	4.24 \pm 4.11	3.02 \pm 1.57	7.40 \pm 5.20	0.10 2.61*
No. of ant columns				

¹ (-) = Akalat absent; (+) = Akalat present.

* p < 0.05

roads) in each forest block were identified and divided into 200m blocks at an interval of 200m. All the blocks were numbered. Seven and four plots in the northern and southern blocks respectively were randomly selected over the whole (99km²). Each 200x200m plot was divided into perpendicular horizontal and vertical trails creating 50x50m grids. Trails were at an interval of 50m.

The observer walked at a slow pace along each trail. At every trail intercept the call of the bird was played for thirty seconds. If a bird was seen or heard singing at or near the grid that was taken as an Akalat positive grid. At every grid a smaller plot of 10m radius was measured and habitat characteristics obtained. At Akalat positive grids five plots (four at an interval of 10m from central plot) were obtained. Only one sampling plot was established at Akalat negative grids.

Within each 200x200m plot the following parameters were determined:

Canopy density above the observer by sighting through a cylinder of diameter 4.5cm (%);

Idem, the *quantity of vegetation* at 2m (low), 3-8m (middle) and above 9m (high) (%);

All *live stems* less and greater than 6cm dbh within each plot;

Dead logs, mossy logs, fallen trees and all *cut stems* of greater than 6cm dbh;

Litter and *herb cover* in one quadrant of 1x1m placed randomly within each plot (%);

Litter depth as measured with a ruler to the nearest mm.

FOOD ABUNDANCE

Britton & Zimmerman (1979) reported that the Akalat feeds on ants and other creeping and flying invertebrates. Due to this diet diversity a number of invertebrate sampling methods were employed. The presence or absence of insects and other invertebrates in each plot was recorded. Creeping invertebrates where ants dominated were generally called 'ants' and their density determined at randomly selected points by using a 10x10cm quadrant. Britton & Zimmerman (1979) also noted that Akalat follow ant (*Siafu*) columns and hence the columns along a transect running through the plot were counted in all the habitats studied. For detailed estimation of food abundance a pitfall method was used. The traps were laid at an interval of 25m along a 1000m transect at all the sites. They were filled with palm wine (*Mnazi*) to attract and kill invertebrates inside the traps. They were collected after twenty-four hours.

DATA ANALYSIS

The distribution of the East Coast Akalat was plotted on a map of Arabuko-Sokoke (Fig 9.2). Its evenness of distribution in the *Cynometra* and Mixed forest was analysed using

Table 9.4 Comparison of habitat parameters of subplots within 200x 200m plots where *Akalat* did occur and did not occur in Mixed forest and *Cynometra* woodland (mean \pm sd)

	MIXED FOREST		CYNOMETRA WOODLAND		t-stat
	(+) present in subplots	(-) absent in subplots	(+) present in subplots	(-) absent in subplots	
Litter depth (mm)	15.96 \pm 4.26	10.79 \pm 3.57	8.62 \pm 3.04	7.83 \pm 2.4	1.13
% litter cover	74.37 \pm 8.63	61.49 \pm 8.83	61.9 \pm 9.84	55.56 \pm 6.46	2.90*
% herb cover	0.92 \pm 1.61	2.47 \pm 3.47	0.82 \pm 0.74	2.76 \pm 2.49	3.00*
No. of fallen trees	0.87 \pm 0.47	1.15 \pm 0.44	1.27 \pm 0.55	1.97 \pm 1.90	1.27
No. of cut stems	1.19 \pm 0.63	1.91 \pm 1.41	2.81 \pm 2.69	3.82 \pm 1.65	1.35
No. dead logs	4.25 \pm 2.52	2.69 \pm 1.65	10.46 \pm 2.2	9.50 \pm 2.86	0.20
No. of mossy logs	2.41 \pm 1.55	0.56 \pm 0.40	5.10 \pm 1.91	4.08 \pm 3.10	1.00
No. of stems < 6 cm dbh	1243 \pm 412	805 \pm 224	1160 \pm 600	1088 \pm 392	0.39
No. of stems > 6 cm dbh	15.09 \pm 3.69	14.56 \pm 4.55	11.64 \pm 2.39	13.86 \pm 4.25	1.70
% Veg. cover at 2 m	47.55 \pm 15.24	30.31 \pm 13.11	47.25 \pm 11.41	40.36 \pm 8.39	3.57*
% Veg. cover at 3-8 m	22.52 \pm 11.34	25.41 \pm 10.58	20.89 \pm 6.55	22.75 \pm 7.36	0.89
% Veg. cover at >9 m	8.47 \pm 6.74	13.59 \pm 7.69	3.03 \pm 1.83	4.40 \pm 2.08	2.20*
% Canopy density	61.12 \pm 10.43	49.22 \pm 19.79	69.17 \pm 7.08	61.73 \pm 5.32	4.71*
Ant density (No./10cm ²)	20.84 \pm 18.42	9.93 \pm 13.78	3.8 \pm 1.91	2.44 \pm 1.79	1.85
No. of ant columns	-	-	0.78 \pm 0.36	0.38 \pm 0.26	4.37*

* p < 0.05

the Kolmogorov-Smirnov Goodness of Fit test. The variables entered in the test were cumulative distance and corresponding number of Akalat recorded for that distance.

To determine the habitat factors important for the Akalat a series of parametric tests were conducted. T-test² was used to detect between and within habitat variations by comparing habitat factors from different habitats, Akalat plot-based densities as well as recently cut stems from the Mixed forest Akalat present and absent plots. ANOVA was used to compare food abundance from these habitats. Subsequently habitat variables were correlated amongst themselves. General Linear Interactive Model (GLIM) 3.77, was used to select the habitat variables that are the best determinants of Akalat density and or distribution.

Results³

DISTRIBUTION

Four habitats were recorded: (i) *Cynometra* woodland, (ii) *Brachystegia* woodland, (iii) *Cynometra* thicket, and (iv) intermediate *Cynometra* woodland. The East Coast Akalat was recorded in the mixed forest and *Cynometra* woodland habitats; only two records were made in the *Brachystegia* woodland and none in the *Cynometra* thicket (Fig 9.2). Occasional records were made in the ecotone of high canopied and intermediate *Cynometra* woodland. Such individuals were considered as wanderers and their site tenacity was ignored in the study on habitat analysis. In the Mixed forest, Akalat were observed to be absent in about a third of the total habitat area (Fig 9.2). This area was under heavy human exploitation through logging, cutting of small saplings and removal of dead logs for fuel-wood. The Akalat was evenly distributed in the *Cynometra* woodland (Kolmogorov-Smirnov, $n=80$, $D=0.095$, $p>.05$) but not in the Mixed forest (Kolmogorov-Smirnov, $n=17$, $D=0.232$, $p<.05$).

POPULATION SIZE AND DENSITY

Fifteen territories were identified and visited for a minimum of four times. Territory sizes (computed from 'reaction distances', i.e. territory diameter) varied between the two habitats; lower distance was recorded in the *Cynometra* compared to the Mixed forest (Table 9.1). Consequently, higher population size and density (based on the transect counts) were recorded in the *Cynometra* woodland. Further, the mean densities were

² Statpac Gold Statistical Package (GOLD)

³ Detailed results are given in Matiku (1996)

Table 9.5 Comparison of habitat parameters in Akalat "hot spots" in *Cynometra* woodland and Mixed forest.

	MIXED FOREST ¹	CYNOMETRA WOODLAND ¹	t-stat
litter depth (mm)	15.96 ± 4.26	8.62 ± 3.04	5.49*
% litter cover	74.37 ± 8.63	61.90 ± 9.85	3.22*
% herb cover	0.92 ± 1.62	0.82 ± 0.74	0.19
No. of fallen trees	0.87 ± 0.47	1.27 ± 0.55	1.91
No. of cut stems	1.19 ± 0.63	2.81 ± 2.69	1.74
No. dead logs	4.25 ± 2.52	10.46 ± 2.20	7.18*
No. of mossy logs	2.41 ± 1.55	5.10 ± 1.91	4.18*
No. of stems < 6 cm dbh	1243 ± 412	1160 ± 600	0.47
No. of stems > 6 cm dbh	15.09 ± 3.69	11.64 ± 5.72	1.94
% Vegetation cover at 2 m	47.55 ± 15.2	47.25 ± 11.4	0.06
% Vegetation cover at 3-8 m	22.52 ± 11.3	20.89 ± 6.55	0.47
% Vegetation cover at >9 m	8.47 ± 7.74	3.03 ± 1.83	2.68*
% Canopy density	61.12 ± 18.40	69.17 ± 7.07	1.39
Ant density (No./10cm ²)	20.84 ± 18.40	3.80 ± 1.91	3.07*
No. of ant columns	0.055 ± 0.18	0.78 ± 0.36	6.62*

¹ mean ± sd

* p<05

Table 9.6

Logistic regression models selecting habitat parameters which best predict the presence of East Coast Akalat in the *Cynometra* woodland and the Mixed forest Akalat present and absent sites ("hot spots").

	CYNOMETRA WOODLAND			MIXED FOREST		
	X ²	df	p <	X ²	df	p <
Full model	226.97	14	.05	171.84	14	.05
Ant density	-	-	-	20.65	1	.05
Mossy logs	15.11	1	.05	18.21	1	.05
Herb cover	9.63	1	.05	-	-	-
Cut stems	8.23	1	.05	6.86	1	.05
Veg. cover at 2 m	5.51	1	.05	7.83	1	.05
Selected model	G(xi)=3.02 (±0.62)			G(xi)=-5.12 (±0.83)		
	+ 0.21 (±0.06) mossy logs			+0.11 (±0.03) ant density		
	-0.2 (±0.08) herb cover			+0.73 (±0.17) mossy logs		
	-0.18 (±0.07) cut stems			+0.04 (±0.02) veg. cover at 2m		
	+0.03 (±0.01) veg. cover 2 m			-0.4 (±0.17) cut stems		

compared as computed from birds responding to playbacks between the *Cynometra* and the Mixed forest plots. The former forest had a higher mean density ($t=5.16$, $p<.05$; unequal variance t-test for density) than the latter.

HABITAT SELECTION AND OCCUPANCY

Broad comparison between habitats

It was found that the two habitats had differing habitat variables in the 200x200m plots, indicating that five (dead logs, mossy logs, number of stems less than 6cm dbh, vegetation cover at 2m high and ant columns) of the fifteen variables were higher in the *Cynometra* woodland compared to the Mixed forest, whereas two variables (vegetation cover at >9m and ant density) were significantly greater in the Mixed forest. Eight habitat variables (litter depth, litter cover, herb cover, fallen trees, cut stems, stems greater than 6cm dbh, vegetation cover at 3-8m and canopy density) were similar. (Table 9.2, $p<.05$).

Nine habitat variables out of 15 showed significant differences between *Cynometra* (A. present) and Mixed forest (A. absent). Of the nine variables there were seven that were higher in the *Cynometra* (litter cover, dead logs, mossy logs, stems less and greater than 6cm dbh, vegetation cover at 2m high and canopy density) and only two were higher in the Mixed forest (cut stems and vegetation cover at 9m). Within the Mixed forest ten variables out of 15 showed significant differences between A. absent and A. present sites. Of the ten variables eight were higher in the A. present sites (litter depth, litter cover, dead logs, mossy logs, stems less and stems greater than 6cm dbh, canopy density and ant density). Only two variables were higher in the A. absent sites (fallen trees, cut stems). (Table 9.3, $p<.05$).

Within *Cynometra* subplots, four habitat variables were higher where the Akalat occurred. These were litter cover, vegetation cover at 2m, canopy density and ant columns. In the Mixed forest Akalat present subplots were defined by greater litter depth, fewer fallen trees, more dead logs, more mossy logs, more stems less than 6cm dbh, higher ant density and more cover at 2m high. (Table 9.4, $p<.05$).

HABITAT VARIABLES IN AKALAT 'HOT SPOTS'

Within the 'hot spots', seven (litter depth, litter cover, dead logs, mossy logs, vegetation cover >9m, ant density and ant columns) out of the fifteen variables were significantly different ($p\leq.05$). Three variables (dead logs, mossy logs, and ant columns) had higher values in the *Cynometra* woodland compared to the Mixed forest, whereas four variables (litter depth, litter cover, vegetation cover at greater than 9m and ant density) were greater in

Table 9.7 *Habitat parameters which best predicted the presence of East Coast Akalat with (+) and without (-) habitat as a factor.**

	(-) HABITAT			(+) HABITAT		
	X ²	df	p<	X ²	df	p<
Full model	318.2	14	.05	401.67	14	.05
Mossy logs	25.64	1	.05	25.29	1	.05
Veg.cover at 2 m	19.98	1	.05	19.98	1	.05
Cut stems	18.29	1	.05	18.29	1	.05
Herb cover	10.77	1	.05	10.77	1	.05
Selected model	G(xi) = -3.17(±0.41)			G(xi) = -3.17(±0.41)		
	+0.04 (±0.01) veg. cover at 2m			+0.04(±0.01) veg. cover at 2m		
	-0.24(±0.07) cutstems			-0.24(±0.07) cutstems		
	+0.23(±0.05) mossy logs			+0.23(±0.05) mossy logs		
	-0.15(±0.06) herbcover			-0.15(±0.06) herbcover		

* All parameters were tested with a stepwise backward procedure calculating the change in scaled deviance that approximates X² (change X² with change df) when a parameter was excluded from the model. Only significant results are presented in the table.

Table 9.8 *Normal multiple regression models selecting habitat parameters which best explain the variation of East Coast Akalat's densities in the Cynometra woodland and the Mixed forest.**

	CYNOMETRA WOODLAND				MIXED FOREST			
	Deviance	X ²	df	p<	Deviance	X ²	df	p<
Ant density	3.98	21.27	1	.05	-	-	-	-
Dead logs	2.37	12.66	1	.05	-	-	-	-
Mossy logs	1.70	9.09	1	.05	3.01	7.81	1	.05
Selected model	Y _(xi) = -0.31 (±0.35)				Y _(xi) = 1.44 (±0.41)			
	+0.16 (±0.31) ant density				+0.45 (±0.10) Mossy logs			
	+0.9 (±0.2) dead logs							
	+2.51 (±0.7) Mossy logs							

* All deviances are assessed by removal of a parameter from the maximal model.

the Mixed forest (Table 9.4). Eight habitat variables were similar for the two habitats and were considered to be important determinant variables in defining the 'hot spots' for the Akalat in either of the habitats (Table 9.5).

To determine the relative role of the eight habitat variables on the distribution of the Akalat, stepwise logistic regression procedures were performed to select habitat variables within each habitat which were the best predictors of the Akalat's presence. Results showed that the best predictors in either of the habitats were mossy logs and vegetation at 2m. Apparently, there were habitat-specific variables that best predicted the occurrence of the Akalat (Table 9.6). However, when data from the two habitats were pooled and analysed, neither of the habitats was selected as one of the predictors; the best predictors were mossy logs, vegetation cover at 2m high, cut stems and herb cover (Table 9.7).

A last analysis was performed to determine which of the habitat variables best predicted the Akalat's density in either of the habitats. Mossy logs were the best predictors of the Akalat density in both the habitats, whereas within the *Cynometra* woodland ant density and dead logs were selected, in addition to mossy logs (Table 9.8). When data were pooled together, only the mossy logs were selected (Model: $D(x) = 1.3 (\pm 0.2) + 0.5 (\pm 0.1)$ mossy logs; $F = 7.56$, $df = 1$; $p < .05$). Mosses were recorded to be used by the bird in nest building.

FOOD ABUNDANCE AND HUMAN DISTURBANCE

This study showed significant variations among the three study sites ($F = 7.048$, $p = .0013$), indicating: (i) significantly higher food abundance in the sites within Mixed forest where Akalat were frequently recorded than where they were not present ($t = 2.4$, $df = 38$, $p < .05$), and (ii) significantly higher food abundance in the *Cynometra* woodland than Mixed forest sites where Akalat was absent ($t = 3.7$, $df = 38$, $p < .001$). Significant differences in means were not detected between *Cynometra* woodland and sites within the Mixed forest that had Akalat present. Significant differences were detected in the Mixed forest indicating that sites without Akalat had higher means of cut stems ($t = 7.417$, $df = 8$, $p < .05$).

BEHAVIOURAL ASPECTS (*Territory size*)

To test whether differences in resources affected the territory sizes, the territories of birds located in the Mixed forest (with patchy distribution of birds) were compared to those recorded in the *Cynometra* woodland. Results from 15 territories showed that territory holders were present in 13 of the 15 visits. Diameter of territories in the Mixed forest

were significantly higher than in the *Cynometra* Woodland ($t=4.225$, $df=13$, $p<.05$).

Discussion

Results of the present study showed that there were differences between the *Cynometra* woodland and the Mixed forest. The *Cynometra* woodland was characterised by: An even distribution of Akalat; small territory sizes; and high population size and density. The best habitat variables that defined the woodland were: High number of dead logs, high number of mossy logs; large number of stems less than 6cm dbh; large number of vegetation at 2m high; and more ant columns. All these parameters were dissimilar to those recorded in the Mixed forest. For example, within the Mixed forest, the bird had a patchy distribution, large territory size, low population density and size. All these differences strongly suggested that the two forest types were structurally and functionally different.

There were, however, similarities between the two forest types, especially where the Akalat was recorded in 200x200m plots. These included: litter depth; litter cover; herb cover; cut stems; vegetation cover at 3-8m, canopy density and fallen trees. There were also similarities recorded in specific sites in which the Akalat were restricted. These were the litter cover, vegetation at 2m high, canopy density and ant columns. Low number of fallen trees were associated with high numbers of Akalat in both forests. In addition, the sites had high number of mossy logs, increased number of stems less than 6cm, high ant density, percentage cover in trees above 9m and percentage vegetation cover at 2m high. These observations suggested that Akalat were significantly associated with ecological niches with specific habitat characteristics.

Habitat factors responsible for Akalat density variations in its habitats would be expected to show significant differences between *Cynometra* woodland and Mixed forest. Significant differences in habitat variables would also be expected between occupied and unoccupied micro sites within either of the habitats. Factors that acted as Akalat' habitat selection cues would not differ significantly between 'hot spots' in both Mixed forest and *Cynometra* woodland and would be selected by Akalat density models. This was the case. Of the 15 experimental habitat variables, only two were selected in both forests (in combination) as the best predictors for the presence of the Akalat. These were mossy logs and vegetation at 2m high. Only mossy logs were selected in the density model suggesting that they can be used as an index of habitat quality for the Akalat. In the previous studies Britton & Zimmerman (1979) argued that the Akalat preferred moist shady and dense habitats. These are habitats in which mosses are likely to be present in large numbers. The observation that nest material comprised mainly of mossy bedding lends credence to Brit-

ton & Zimmerman's hypothesis and further suggests that mossy logs are key survival resources for the Akalat.

Other key factors that affected the Akalat were availability of food and minimum human influence through logging. As was expected more birds were located in areas that had the highest potential sources of food with minimum recent cut stems. Apparently, the difference in the Akalat distribution in Arabuko-Sokoke is linked to the uniformity and patchiness of its survival resources in the *Cynometra* woodland and Mixed forest, respectively. The heavy removal of dead logs and logging from the Mixed forest could be the two most important determinants of Akalat patchiness in the habitat.

Environmental patchiness may have led to multimodal abundance patterns, or abrupt environmental changes may have produced truncated distributions in which abundance was higher in the *Cynometra* woodland than in the Mixed forest. Logistic regression models selected mossy logs as the one single most important habitat variable for both experimental habitats. The removal of dead logs for fuelwood in the Mixed forest, among other human activities (e.g. logging) might further reduce the range of the Akalat.

In theory there is some basic configuration or pattern in the environment that an individual animal will seek out and settle in. This habitat selection process may be based on a specific search image, early learned experience, the particular genetic make up of the individual, or any combination of these factors (Klopfer, 1970). Presumably, then, habitat selection is an evolutionary derived mechanism that ensures that individuals seek out and remain in the particular environment to which they are best suited. The absence of the Akalat in a vast majority of vegetation types even those adjacent to the most favourable habitats puts occupation by chance far from consideration.

The recognition stimuli that induce a bird or any other animal to select a particular habitat may often appear to be related to the actual survival and successful reproduction of that organism (Hilden, 1965). For example, in this study mossy logs correlated significantly with Akalat densities and appeared as a common denominator for all the logistic models that selected habitat parameters predictive of Akalat presence in its ranges, suggesting its significant role in reproduction and survival of the species. Mossy log could therefore be a significant niche requirement as it provides nesting substrate.

It was predicted that the patchy distribution of the Akalat in the Mixed forest was related to uneven distribution of survival resources in the habitat. Even distribution of Akalat would be expected if survival resources were evenly distributed in the Mixed forest. If individuals respond to within-plot habitat variations in locating their territories, a comparison of the habitat features in the occupied areas with those in the unoccupied areas may reveal

non random patterns of habitat occupancy (Wiens, 1992). On the other hand, if portions of a plot are unoccupied by a species because of inter-specific territorial exclusion, low population density, or chance effects in the placement of territories, consistent differences in habitats between occupied and unoccupied areas should not be evident (Wiens, 1992). Thus, the pattern of distribution of Akalat in the present study was determined by factors unrelated to chance alone.

Food is often thought to be an important factor in defining territory size. The range an animal occupies to satisfy its energetic or reproductive requirements depends on the abundance and distribution of food. At one extreme, if the resource is of poor quality and sparsely distributed the animal will have to roam over a large area and it is unlikely that it will be able to defend this economically (Krebs & Houston, 1989). The observation that territory sizes were larger in the Mixed forest strongly suggested that the abundance of preferred food was in short supply. The observation that there were fewer ant columns in the Mixed forest supported this prediction. If this reasoning is valid, one prediction can be made from the present study: that the rate of reproduction of the Akalat in Arabuko-Sokoke should be higher in the *Cynometra* woodland than in the Mixed forest.

Svardson (1949) suggested that increasing density should be associated with an increase in the range of habitats occupied by a species because the intensified intra-specific competition forces some individuals to occupy marginal habitats. This thinking was formalised in the models of Brown (1969) and Fretwell & Lucas (1970). The former proposed that habitats differ in their suitability to a species and that individuals will preferentially select the most suitable habitat. The latter modelled habitat occupancy as a function of the fitness potential ('quality') of habitat types. Some habitats are of better inherent quality than others, and these will be occupied first. As density within that habitat increases, however, the fitness potential of the habitat declines. Eventually a point is reached at which an individual may realise equivalent reproduction success by occupying instead another habitat of slightly poorer quality. Apparently, *Cynometra* woodland was the optimal habitat relative to the Mixed forest. The observation that small territories were recorded in the *Cynometra* compared to Mixed forest is consistent with this line of thinking.

The ecological tolerances of species dictate the environmental situations they can occupy and how these conditions are met in space determines where the species may occur (Wiens, 1992). Species that have restricted habitat affinities are likely to be absent beyond the distribution of the appropriate habitat type (Mayfield, 1960). In the present study (see also Nemeth, 1996) the bird was recorded in the northern and in only a few parts of the southern Mixed forest and in the north-eastern and south-western parts of the *Cynometra*

forest. Perhaps these were areas that provided adequate ecological requirements to the Akalat.

Conclusion

The distribution of the East Coast Akalat was limited to *Cynometra* woodland and Mixed forest. Akalat population size and density was higher in the *Cynometra* woodland than in the Mixed forest. Habitat factors predicted to be important for the Akalat occurred more readily in the *Cynometra* woodland than in the Mixed forest. Mossy logs and vegetation cover at 2m high were the most significant variables that predicted the occurrence of Akalat in the experimental habitats. Features of this study strongly suggest that human activities (i.e. logging and collection of dead logs) influence the distribution patterns of the Akalat. Thus, urgent measures to provide alternative fuelwood, need to be addressed to lower the illegal exploitation of trees that continues inside Arabuko-Sokoke. For example, research into tree nursery facilities and regeneration capacity of the indigenous forest would help alleviate the immediate social needs.

Research into the diet and breeding success of the East Coast Akalat in its ranges is crucial. It would be interesting to determine the role of mossy logs as indicators of habitat quality for other taxonomic groups.

Abstract

This study was carried out on a nearly threatened East Coast Akalat (*Sheppardia gunningi sokokensis* Van Someren 1921) in two forest types (*Cynometra* woodland and Mixed forest) in Arabuko-Sokoke Forest to determine the proximate factors that influenced its spatial distribution. Playback was used to stimulate the bird to reveal its presence. Fifteen habitat factors predicted to be important as cues for habitat selection were recorded from territory and non-territory sites and compared. Normal and logistic regression models were used to select the best habitat predictors of Akalat distribution and density. The best habitat predictors for the occurrence of Akalat (in both habitats combined) were mossy logs and vegetation cover at 2m; sites without Akalat had higher numbers of cut stems. The greatest amount of food was associated with the presence of Akalat; larger territories were located in the Mixed forest compared to the *Cynometra* woodland; the bird was more evenly distributed in the *Cynometra* than in the Mixed forest; higher population density was recorded in the *Cynometra* than in the Mixed forest. Results suggest that (i) East Coast Akalat has the ability to select micro habitats suitable for its survival; (ii) human activities affect the population density and distribution of Akalat by affecting vegetation structure suitable for the Akalat; (iii) mossy logs and vegetation cover at 2m high can be used as quick rapid indices in predicting habitat quality for the Akalat.

Acknowledgements

We thank David Ngala, Edward Waiyaki, Oliver Nasirwa, Peter Njoroge and Patrick Gichuki for assisting in the field work; Dr. Erwin Nemeth for providing transport; Mrs Ann Robertson for providing the maps of Arabuko-Sokoke Forest; Mr Kirui (District Warden) Mr. Kimini (District Forester) and Mr. Mwasaa (Forester) availed information about the Forest. This study was funded by the Dutch Government scholarships to PMM. Additional funds were obtained from Birdlife-Kenya.

References

- Britton P L & Zimmerman D A (1979). The avifauna of Sokoke Forest, Kenya. *Journal of the East African Natural History Society and National Museum*, 169, 1-15.
- Brown J L (1969). Territorial behaviour and population regulation in birds: A review and re-evaluation. *Wilson Bulletin*, 81, 293-329.
- Collar N J & Stuart S N (1988). *Key forests for threatened birds in Africa*. Cambridge: International Council for bird preservation/IUCN. Monograph No.3 S-print.
- Collar N J, Crosby M J & Stattersfield A J (1994). *Birds to watch 2: The world list of threatened birds*. Cambridge: Birdlife International. Conservation series, no.4.
- Fretwell S D & Lucas H L (1970). Territorial behaviour and factors influencing distribution in birds. *Acta Biotheoretica*, 19, 16-36.
- Hilden O (1965). Habitat selection in birds. *Annals Zoologic Fennici*, 2, 53-75.
- Keith S (1992). *Birds of Africa*. Volume IV. London: Academic Press.
- Kelsey M G & Langton T E S (1984). *The conservation of the Arabuko-Sokoke forest, Kenya*. International Council for Bird Preservation and University of East Anglia. Study Report no. 4.
- Klopfer P (1970). *Behavioural ecology*. Dunham: Duke University Press.
- Krebs J R & Houston A I (1989). *Optimization in ecology*. Oxford: Blackwell
- Matiku P M (1996). *Habitat selection and distribution of the East Coast Akalat (Sheppardia gunningi sokokensis) in Arabuko-Sokoke Forest, Kenya*. M.Phil. thesis, Moi University, School of Environmental Studies.
- Mayfield J (1960). A major extinction spasm: Predictable and inevitable. In D Western & M Pearl (eds), *Conservation for the twenty-first century*. New York: Oxford University Press.
- Nemeth E (1996). *The behaviour of the East Coast Akalat (Sheppardia gunningi sokokensis)*. Wien: Konrad Lorenz Institute.
- Svardson G (1949). Competition and habitat selection in birds. *Oikos*, 1, 157-174.
- Wiens J A (1989). *The ecology of bird communities. Volume I: Processes and variations*. Cambridge: Cambridge University Press.
- Wiens J A (1992). *The ecology of bird communities. Volume II. Foundation and patterns*. Cambridge: Cambridge University Press.

Authors

Abuodha, Joseph

Moi University, School of Environmental Studies.
P.O.Box 3900, Eldoret. Tel. 0321.43244; Fax 0321.43149.

Anyango, Stephen O.

Dept. of Environment Science, Kenyatta University.
P.O.Box 43844, Nairobi. Tel.02.811622; Fax 02.811575.

Bennun, Leo

National Museums of Kenya, Department of Ornithology
P.O.Box 40658, Nairobi. Tel.02.732161-2; Fax 02.741424.

Hoorweg, Jan

Moi University, Coast Environment Research Station.
P.O.Box 710, Malindi. Tel. 0123.30093; Fax 0123.30173.

Kamau, Francis K.

East African Wildlife Society.
P.O.Box 1043, Wundanyi. Tel. 0148.2111.

Manobar, S.

Moi University, School of Environmental Studies.
P.O.Box 3900, Eldoret. Tel. 0321.43244; Fax 0321.43149.

Matiku, Paul M.

National Museums of Kenya, Department of Ornithology.
P.O.Box 40658, Nairobi. Tel.02.732161-2; Fax 02.741424.

Munyao, Thomas M.

Moi University, Coast Environment Research Station.
P.O.Box 710, Malindi. Tel. 0123.30093; Fax 0123.30173.

Musila, Winfred M.

Centre for Biodiversity, National Museums of Kenya.
P.O.Box 40658, Nairobi. Tel.02.732161-2; Fax 02.741424.

Mzuga, Jason M.

Chemistry Department, Egerton University.
P.O.Box 536, Njoro. Tel. 037.61032; Fax 037.61527.

Odanga, Jetbro F.E.

Moi University, Department of Wildlife Management.
P.O.Box 3900, Eldoret. Tel.0321.63161; Fax 0321.63206.

Ouko, Evans M

Moi University, School of Environmental Studies.
P.O.Box 3900, Eldoret. Tel. 0321.43244; Fax 0321.43149.

Tole, Mwakio P.

Moi University, School of Environmental Studies.
P.O.Box 3900, Eldoret. Tel. 0321.43244; Fax 0321.43149.

Ucakuun, E.K

Moi University, School of Environmental Studies.
P.O.Box 3900, Eldoret. Tel. 0321.43244; Fax 0321.43149.

DUNES, GROUNDWATER, MANGROVES AND BIRDLIFE IN COASTAL KENYA

Jan Hoorweg, ed.

Coral reefs, wetlands, mangroves and lowland forests are important ecosystems of the Kenyan Coast that have received different degrees of attention from conservationists and ecologists. Coral reefs are among the most complex marine ecosystems. Mangrove forests are widespread and provide nurseries for fish and crustaceans in addition to protecting the coastline from erosion. Coastal wetlands are meeting grounds of marine and terrestrial species. The lowland forests, finally, are characterized by great biodiversity, as regards both flora and fauna.

This natural environment is threatened in many ways. Coral reefs are deteriorating, mangrove forests are overexploited, forest reserves are threatened, unrestricted surface mining leads to erosion and ground water is increasingly saline and contaminated. The damage occurs to some extent from naturally occurring geophysical processes, but more from the increased subsistence needs of the population and from growing commercial exploitation. If current trends continue unchecked, many aspects of coastal ecology will suffer irreparable damage.

The School of Environmental Studies of Moi University has placed coastal ecology high on the research agenda. The Coast Environment Research Station (CERS) was started in Malindi in 1996. Recent thesis research is concerned with coastal topics in Kwale and Kilifi District. So far, seven M.Phil. studies and one Ph.D. study have been completed. This monograph presents eight papers with the main findings of these studies.

Abuodha and Musila analyzed the sediments and dunes of the Sabaki River. Munyao studied sediments in Shirazi-Funzi Lagoon. Anyango and Mzuga examined groundwater in Kwale District; the former in relation to sea water intrusion, the latter in respect of water quality and contamination. Ouko and Kamau were concerned with mangroves; the first assessed the condition of mangrove swamps with different degrees of exposure to human exploitation, the latter examined the biological aspects of mangrove conservation and regeneration. Matiku, finally, studied one of the threatened bird species in the Arabuko-Sokoke Forest.

Jan Hoorweg is Visiting Professor at Moi University, Eldoret and senior researcher at the African Studies Centre, Leiden. Formerly Director of the Food and Nutrition Studies Programme; he is currently co-ordinator of the Coast Environment Research Station.

ACTS PRESS

P.O. Box 45917
Nairobi, Kenya

Tel: (254-2) 565173; 569986
ISBN 9966-41-101-1